

	DATE	EC NO.	PART NO.	
REL	08/03/04	J62731	13R1439	
			DEVELOPMENT NO.	Q/M
				1 /83

# AP13 PLANAR (M9/KINNERETH-R BASE)

VER 0.70 AUG/03/2004

- |                                 |   |
|---------------------------------|---|
| 1. TITLE PAGE                   | 44. EMC DECOUPLING                      |
| 2. EC HISTORY                   | 45. MINI PCI SLOT                       |
| 3. CPU(1/3)                     | 46. PCI BUS SWITCH                      |
| 4. CPU(2/3)                     | 47. DOCKING CONNECTOR                   |
| 5. CPU(3/3)                     | 48. FWH,RTC BATTERY                     |
| 6. ITP CONN                     | 49. H8S/2169A                           |
| 7. VCCCPUCORE DECOUPLING        | 50. KEYBOARD CONNECTOR                  |
| 8. MCH-M(1/4)                   | 51. TOUCH PAD CONNECTOR                 |
| 9. MCH-M(2/4)                   | 52. MISC G/A (PMH-4)                    |
| 10. MCH-M(3/4)                  | 53. DC-DC VCCCPUCORE DECAP              |
| 11. MCH-M(4/4)                  | 54. SUPER I/O PC87392                   |
| 12. DDR SO DIMM CONNECTOR 0     | 55. SERIAL INTERFACE                    |
| 13. DDR SO DIMM CONNECTOR 1     | 56. EXT CRT INTERFACE                   |
| 14. SSTL-2 TERMINATION          | 57. TV-OUT                              |
| 15. SSTL-2 DECOUPLING           | 58. PARALLELL INTERFACE                 |
| 16. CLOCK GEN(CK-TITAN)         | 59. THERMAL SENSOR                      |
| 17. RADEON M9_CSP (1/7)         | 60. I2CBUS/SMBUS/CRYPT                  |
| 18. RADEON M9_CSP (2/7)         | 61. FAN CONTROL                         |
| 19. RADEON M9_CSP (3/7)         | 62. DC-IN AND CHARGER                   |
| 20. RADEON M9_CSP (4/7)         | 63. CHARGE SELECTOR                     |
| 21. RADEON M9_CSP (5/7)         | 64. BATTERY INPUT                       |
| 22. RADEON M9_CSP(6/7)(7/7)     | 65. BATTERY MONITOR                     |
| 23. DC/DC MAX_PWR CTRL          | 66. POWER SEQUENCE                      |
| 24. LCD CONNECTOR               | 67. DC-DC VCC3M/VCC5M(MAX1631)          |
| 25. ICH4-M(1/3)                 | 68. DC-DC VCCCPUCORE (ADP3205)          |
| 26. ICH4-M(2/3)                 | 69. DC-DC VCC1R2M/VCCCPUIO(MAX1845)     |
| 27. ICH4-M(3/3)                 | 70. DC-DC VCC2R5A/VCC1R25B(MAX1845)     |
| 28. HDD I/F CONNECTOR           | 71. DC-DC VCC1R8M/VCCVIDEOCORE(MAX1844) |
| 29. CLEAN SHEET BAY             | 72. VCC1R5M/A/B/AUX                     |
| 30. USB POWER                   | 73. TSURUMAI                            |
| 31. AUDIO AD1981A               | 74. GIGABIT ETHER LOAD SW               |
| 32. AUDIO MISC                  | 75. LOAD SW                             |
| 33. AUDIO INT MIC               | 76. GIGABIT ETHERNET (1/3)              |
| 34. AUDIO HP & LINE IN CONN     | 77. GIGABIT ETHERNET (2/3)              |
| 35. AUDIO EXT MIC CONN          | 78. GIGABIT ETHERNET (3/3)              |
| 36. AUDIO SPEAKER               | 79. IR MODULE / LARGE PTH HOLE          |
| 37. AUDIO HDP AMP AN12942A(1/2) | 80. USB INTERFACE                       |
| 38. AUDIO HDP AMP AN12942A(2/2) | 81. RJ11/RJ45 CONNECTOR                 |
| 39. CDC CONNECTOR               | 82. G-SENSOR                            |
| 40. CARD BUS PCI4520(1/2)       | 83. RGB ANALOG SWITCH                   |
| 41. CARD BUS PCI4520(2/2)       |   |
| 42. CARD BUS POWER CTRL         |   |
| 43. CARD BUS SLOT               |   |

13R1439

DESIGNER	Y.I	08/03/04	PART NO.	
CHECKED	Y.Y	08/03/04	13R1439	
APPROVED	K.T	08/03/04	TITLE ROME-3.5 AP13 (V070)	
CLASS	K.T	08/03/04	TITLE PAGE	
<small>THIS DOCUMENT IS THE PROPERTY OF IBM. ITS USE IS AUTHORIZED ONLY FOR RESPONDING TO A REQUEST FOR QUOTATION OR FOR THE PERFORMANCE OF WORK FOR IBM. ALL QUESTIONS MUST BE REFERRED TO THE IBM PURCHASING DEPARTMENT.</small>				IBM CONFIDENTIAL

# EC HISTORY

	DATE	EC NO.	PART NO.
REL	08/03/04	J62731	13R1439
			DEVELOPMENT NO.
			Q/M
			2 /83

## SIV

VER.0.18 03/10/2003 NOT APPLIED RM2\_EC\_SIV001  
 VER.0.19 03/13/2003 APPLIED RM2\_EC\_SIV002  
 VER.0.20 03/17/2003 APPLIED RM2\_EC\_SIV003  
 VER.0.21 03/18/2003 APPLIED RM2\_EC\_SIV004  
 VER.0.22 03/19/2003 APPLIED RM2\_EC\_SIV005  
 VER.0.23 03/31/2003 APPLIED RM2\_EC\_SIV006  
 VER.0.24 04/01/2003 APPLIED RM2\_EC\_SIV007  
 VER.0.25 04/04/2003 APPLIED RM2\_EC\_SIV008  
 VER.0.26 04/07/2003 APPLIED RM2\_EC\_SIV009  
 VER.0.27 04/09/2003 APPLIED EC BY MEMO@APR/08

## SIT

VER.0.28 04/09/2003 APPLIED AP\_EC\_SIT001  
 VER.0.29 04/15/2003 APPLIED AP\_EC\_SIT002

## SIT M10-7A

VER.0.30 04/16/2003 APPLIED AP\_EC\_M10\_01  
 VER.0.31 04/24/2003 NOT APPLIED  
 VER.0.32 04/28/2003 NOT APPLIED  
 VER.0.33 04/28/2003 APPLIED AP\_EC\_M10\_02/03/04  
 VER.0.34 04/30/2003 APPLIED AP\_EC\_M10\_05  
 VER.0.35 05/06/2003 NOT APPLIED  
 VER.0.36 05/06/2003 APPLIED AP\_EC\_M10\_06  
 VER.0.37 05/08/2003 NOT APPLIED  
 VER.0.38 05/08/2003 APPLIED AP\_EC\_M10\_07  
 VER.0.39 05/09/2003 NOT APPLIED  
 VER.0.40 05/09/2003 APPLIED AP\_EC\_M10\_08  
 VER.0.41 05/21/2003 APPLIED AP\_EC\_M10\_09/10  
 VER.0.42 05/28/2003 APPLIED AP\_EC\_M10\_11  
 VER.0.43 06/03/2003 APPLIED AP\_EC\_M10\_12

## SVT-AP5

VER.0.44 06/03/2003 APPLIED AP5\_EC\_001  
 VER.0.45 06/04/2003 APPLIED AP5\_EC\_002  
 VER.0.46 06/05/2003 APPLIED AP5\_EC\_003  
 VER.0.47 06/06/2003 APPLIED AP5\_EC\_004

SVT(AP5) GERBER RELEASE ON 06/11/2003

VER.0.48 06/12/2003 APPLIED AP5\_EC\_005

## SVT-AP6

VER.0.49 07/23/2003 APPLIED AP6\_EC\_001(MAX CTRL EC)  
 VER.0.50 07/25/2003 APPLIED AP6\_EC\_002(CHANGE Q86 TO FDC655AN)

SVT(AP6) GERBER RELEASE ON 07/31/2003

## AP7

VER.0.51 09/24/2003 APPLIED AP7\_EC\_001  
 VER.0.52 09/25/2003 APPLIED AP7\_EC\_002  
 VER.0.53 09/26/2003 APPLIED AP7\_EC\_003 AND CHARACTER SIZE CHANGE.

AP7 GERBER RELEASE ON 09/30/2003

VER.0.54 10/03/2003 APPLIED AP7\_EC\_004  
 VER.0.55 10/21/2003 APPLIED AP7\_EC\_005/006

## AP9

VER.0.56 10/31/2003 APPLIED AP9\_EC\_001/002  
 AP9 GERBER RELEASE ON 11/05/2003  
 VER.0.57 11/20/2003 CHANGE R187/R197 TO 100.  
 AP9 GERBER RE-RELEASE ON 12/01/2003  
 VER.0.58 12/02/2003 ADD AP9 GERBER RE-RELEASE DATE.  
 VER.0.59 12/10/2003 CHANGE R881 FROM 20K TO 39K.  
 CHANGE C65 FROM 2200PF TO 1000PF.  
 CHANGE F4 FROM 0.5 A TO 2.0A FOR M10 MODEL ONLY.  
 VER.0.60 12/26/2003 CHANGE R208(PANAR ID) TO NO-ASM.  
 CHANGE D100(1SS400) TO ASM FOR RK9M ONLY.  
 CHANGE FL8 TO 47 OHM EXCEPT FOR RK9M(MEMSIC).

## AP10

VER.0.61 03/15/2004 SHORT BETWEEN #1 AND #5/6 OF THE FOLLOWINF FET  
 TO SOLVE PARTS SHORTAGE PROBLEM.  
 VCC3M --- Q18 (ALSO Q100 FOR CONFIG RK)  
 VCC1R2M --- Q2  
 VCCCPU10 --- Q6  
 VCC1R25B --- Q51  
 VCC1R8M --- Q71

AP10 GERBER RELEASE ON 03/17/2004

## AP11

VER.0.62 03/19/2004 ADD C987 TO SOLVE AE2000 SHUTDOWN PROBLEM.  
 TO SOLVE PART SHORTAGE PROBLEM.

AP11 GERBER RELEASE IS 03/23/2004

## AP12

VER.0.63 04/19/2004 ADD 5 220PF CAPS(C988 TO C992) TO PROTECT FROM ESD.

AP12 GERBER RELEASE IS 05/12/2004

## AP13

VER.0.64 05/27/2004 APPLY AP13\_EC\_01/02.  
 VER.0.65 06/01/2004 APPLY AP13\_EC\_03/04.

AP13 GERBER RELEASED ON 06/09/2004.

VER.0.66 06/21/2004 APPLY AP13\_EC\_06.  
 VER.0.67 07/16/2004 APPLY AP13\_EC\_07.  
 VER.0.68 07/21/2004 APPLY AP13\_EC\_08.  
 VER.0.69 07/22/2004 APPLY AP13\_EC\_09.  
 VER.0.70 08/03/2004 ASSIGN LOGIC DWG PN/EC#.

13R1439

DESIGNER	Y.I	08/03/04	PART NO.	13R1439	
CHECKED	Y.Y	08/03/04			
APPROVED	K.T	08/03/04	TITLE ROME-3.5 AP13 (V070)		
CLASS	K.T	08/03/04	HISTORY		
THIS DOCUMENT IS THE PROPERTY OF IBM. ITS USE IS AUTHORIZED ONLY FOR RESPONDING TO A REQUEST FOR QUOTATION OR FOR THE PERFORMANCE OF WORK FOR IBM. ALL QUESTIONS MUST BE REFERRED TO THE IBM PURCHASING DEPARTMENT.				IBM CONFIDENTIAL	

REL	DATE	EC NO.	PART NO.	
	08/03/04	J62731	13R1439	
			DEVELOPMENT NO.	Q/M
				3 / 83

U58

BANIAS (1/3)

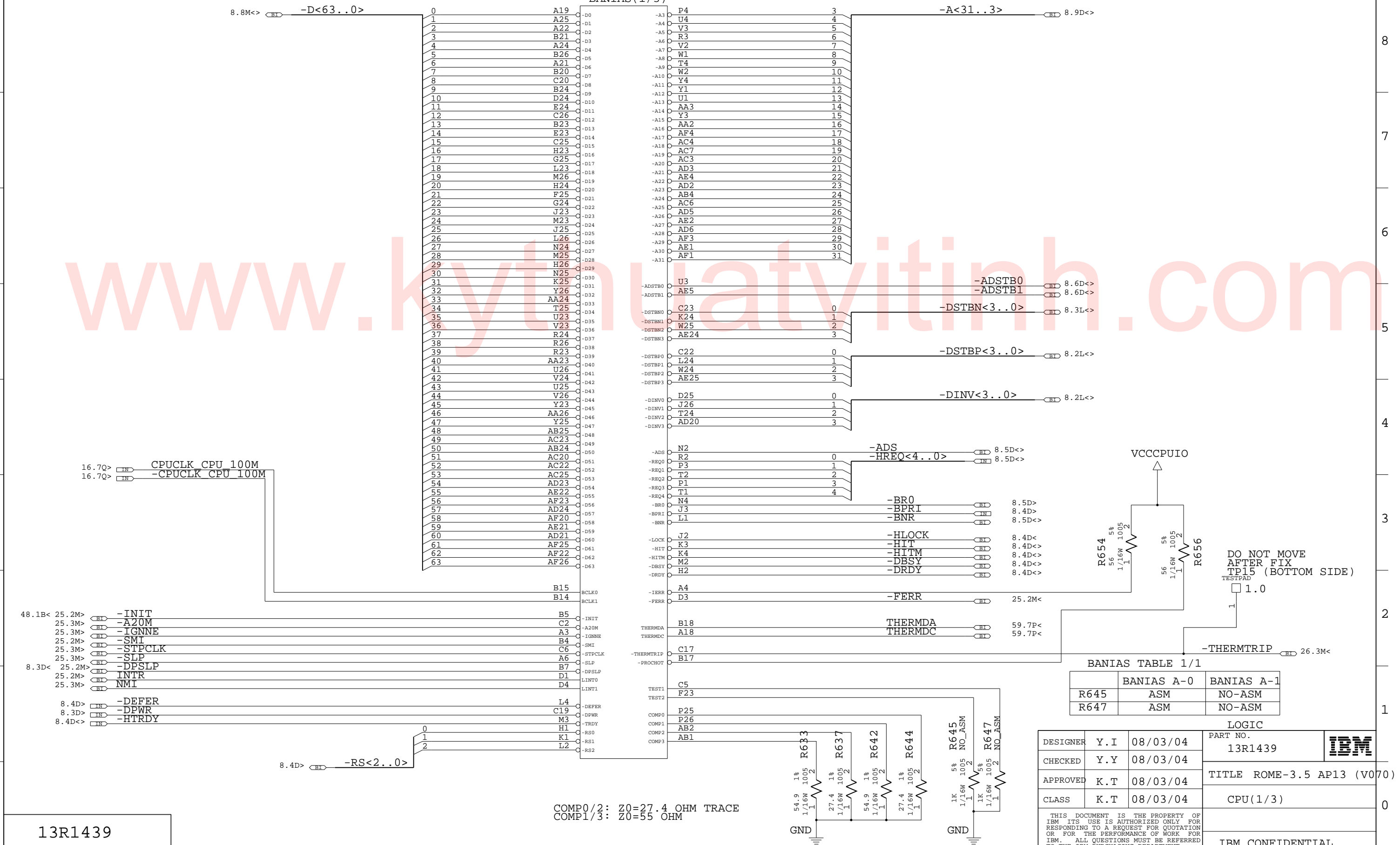

COMP0/2: Z0=27.4 OHM TRACE  
COMP1/3: Z0=55 OHM

BANIAS TABLE 1/1

	BANIAS A-0	BANIAS A-1
R645	ASM	NO-ASM
R647	ASM	NO-ASM

DESIGNER	Y.I	08/03/04	PART NO.	13R1439	
CHECKED	Y.Y	08/03/04	TITLE		
APPROVED	K.T	08/03/04	CLASS	CPU(1/3)	
THIS DOCUMENT IS THE PROPERTY OF IBM. ITS USE IS AUTHORIZED ONLY FOR RESPONDING TO A REQUEST FOR QUOTATION OR FOR THE PERFORMANCE OF WORK FOR IBM. ALL QUESTIONS MUST BE REFERRED TO THE IBM PURCHASING DEPARTMENT.				IBM CONFIDENTIAL	

13R1439

	DATE	EC NO.	PART NO.	
REL	08/03/04	J62731	13R1439	
			DEVELOPMENT NO.	Q/M
			4	/83

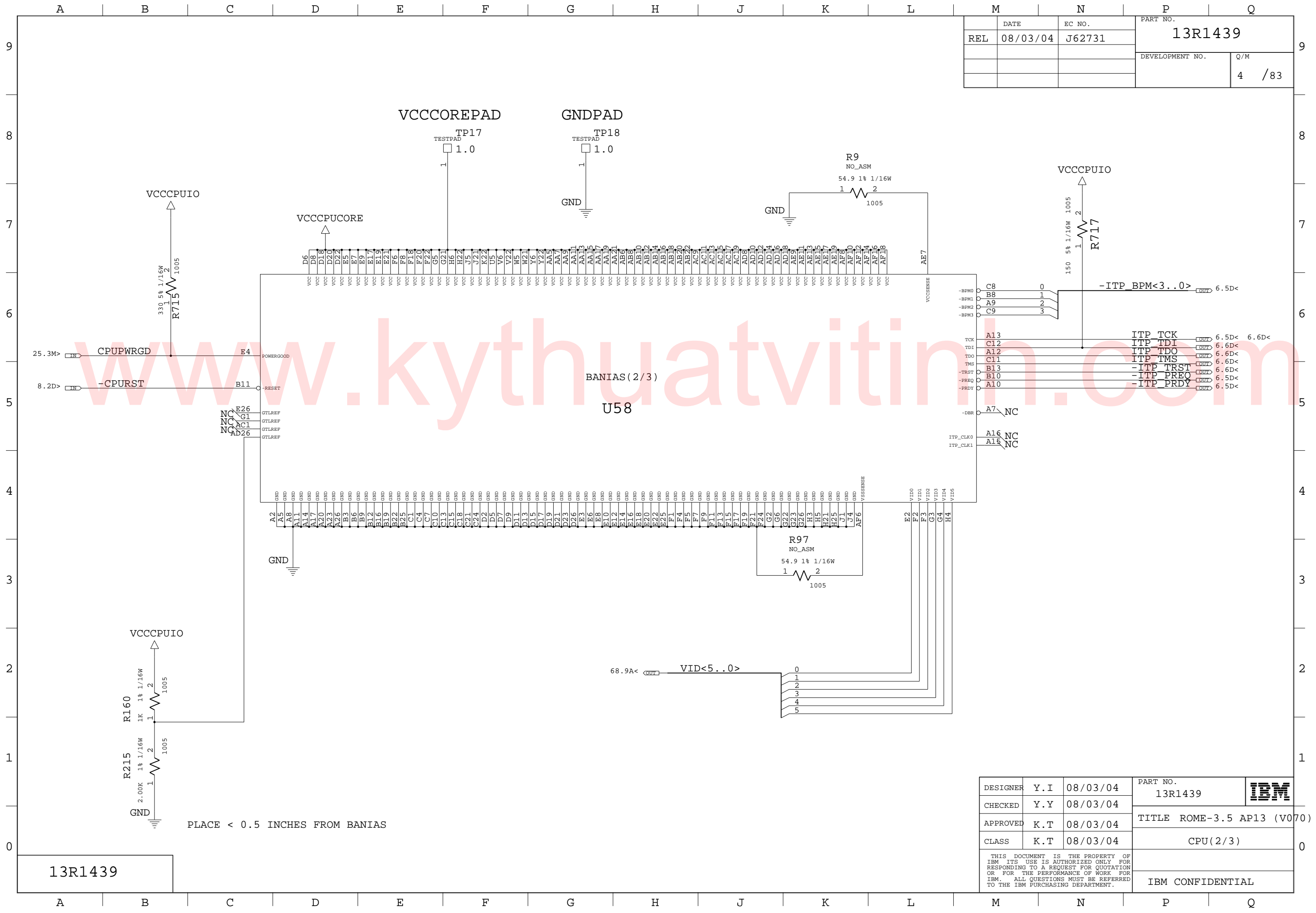

PLACE < 0.5 INCHES FROM BANIAS

13R1439

DESIGNER	Y.I	08/03/04	PART NO.	13R1439	
CHECKED	Y.Y	08/03/04			
APPROVED	K.T	08/03/04	TITLE ROME-3.5 AP13 (V070)		
CLASS	K.T	08/03/04	CPU(2/3)		
THIS DOCUMENT IS THE PROPERTY OF IBM. ITS USE IS AUTHORIZED ONLY FOR RESPONDING TO A REQUEST FOR QUOTATION OR FOR THE PERFORMANCE OF WORK FOR IBM. ALL QUESTIONS MUST BE REFERRED TO THE IBM PURCHASING DEPARTMENT.					IBM CONFIDENTIAL

	DATE	EC NO.	PART NO.	
REL	08/03/04	J62731	13R1439	
			DEVELOPMENT NO.	Q/M
			5	/83

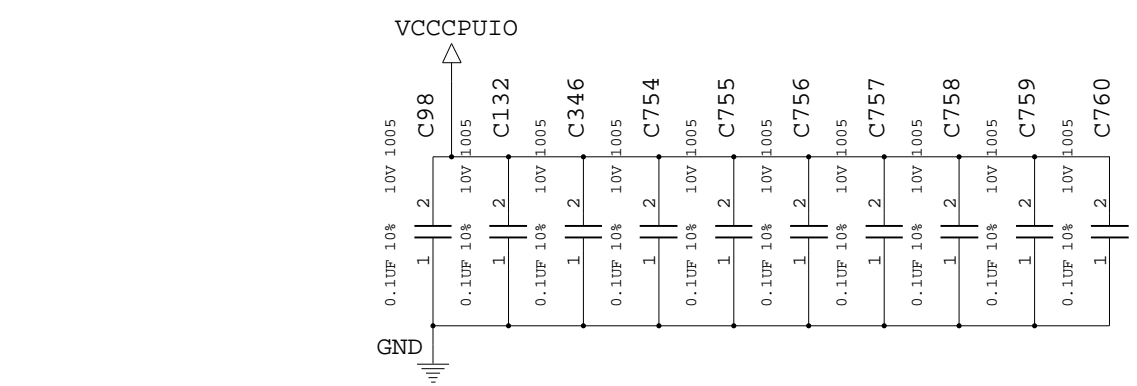

VCC1R8B

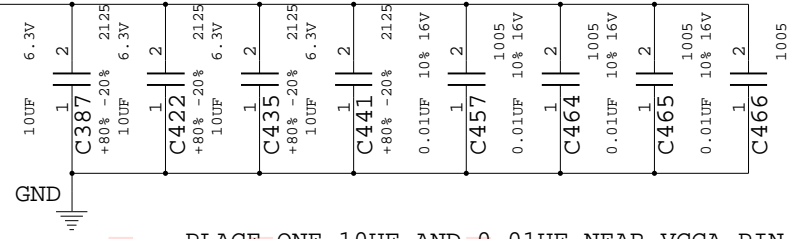

PLACE ONE 10UF AND 0.01UF NEAR VCCA PIN.

VCCCPUIO

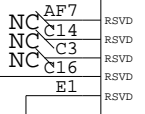
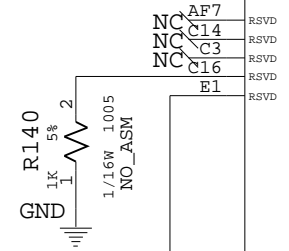
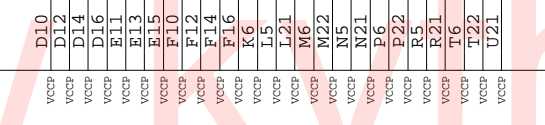

BANIAS (3/3)

U58

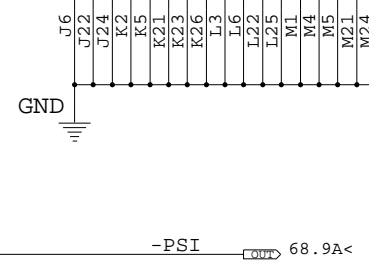

-PSI 68.9A<

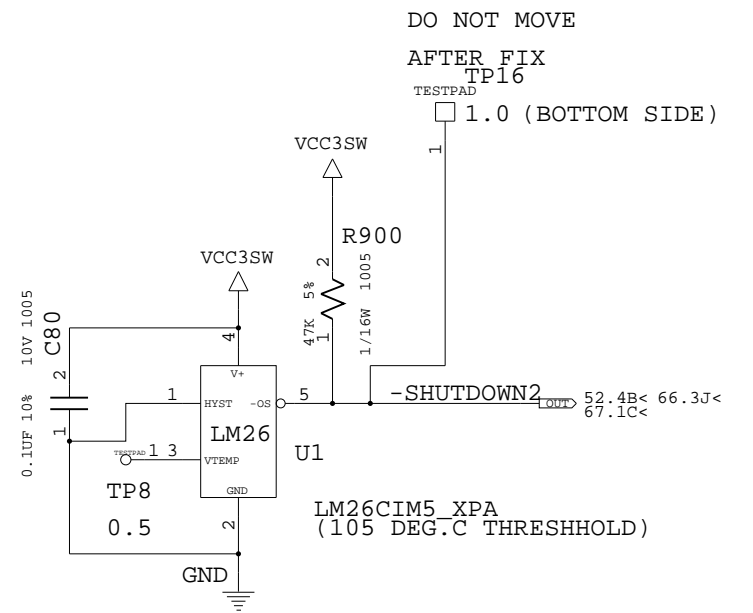
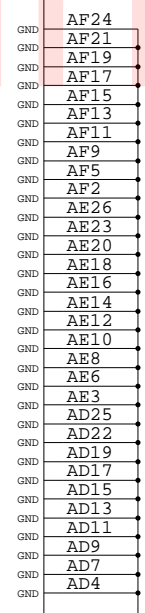

DO NOT MOVE  
AFTER FIX  
TP16  
TESTPAD  
1.0 (BOTTOM SIDE)

LM26CIM5\_XPA  
(105 DEG.C THRESHOLD)

13R1439

DESIGNER	Y.I	08/03/04	PART NO.	13R1439	
CHECKED	Y.Y	08/03/04			
APPROVED	K.T	08/03/04	TITLE ROME-3.5 AP13 (V070)		
CLASS	K.T	08/03/04	CPU(3/3)		
THIS DOCUMENT IS THE PROPERTY OF IBM. ITS USE IS AUTHORIZED ONLY FOR RESPONDING TO A REQUEST FOR QUOTATION OR FOR THE PERFORMANCE OF WORK FOR IBM. ALL QUESTIONS MUST BE REFERRED TO THE IBM PURCHASING DEPARTMENT.					IBM CONFIDENTIAL

	DATE	EC NO.	PART NO.	
REL	08/03/04	J62731	13R1439	
			DEVELOPMENT NO.	Q/M
			6	/83

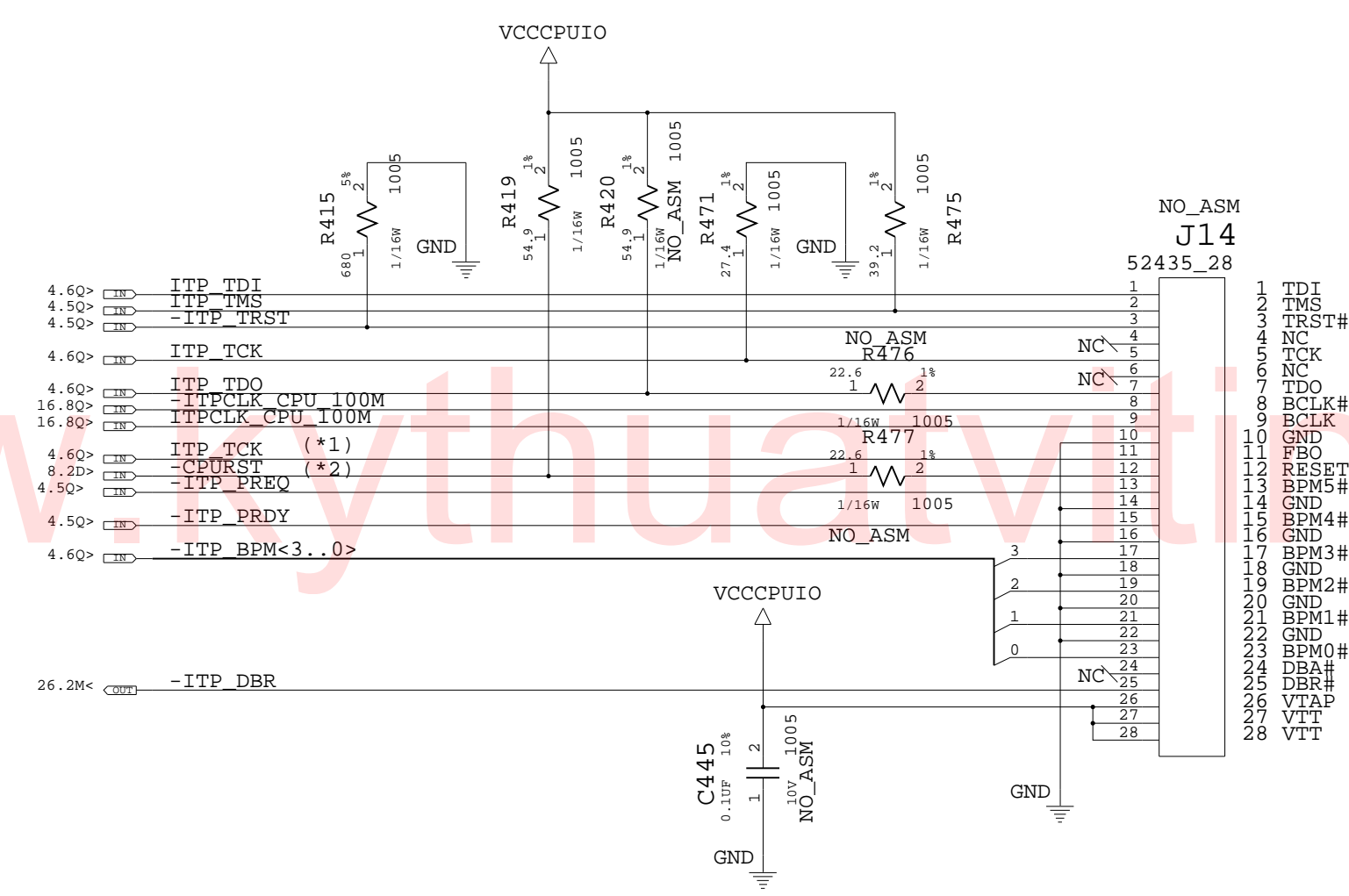

(\*1) TCK SIGNAL IS BRANCHED AT BANIAS PIN  
 (\*2) -CPURST SIGNAL IS BRANCHED AT ODEM PIN

13R1439

DESIGNER	Y.I	08/03/04	PART NO.	13R1439	
CHECKED	Y.Y	08/03/04			
APPROVED	K.T	08/03/04	TITLE ROME-3.5 AP13 (V070)		
CLASS	K.T	08/03/04	ITP CONN		
THIS DOCUMENT IS THE PROPERTY OF IBM. ITS USE IS AUTHORIZED ONLY FOR RESPONDING TO A REQUEST FOR QUOTATION OR FOR THE PERFORMANCE OF WORK FOR IBM. ALL QUESTIONS MUST BE REFERRED TO THE IBM PURCHASING DEPARTMENT.				IBM CONFIDENTIAL	

	DATE	EC NO.	PART NO.	
REL	08/03/04	J62731	13R1439	
			DEVELOPMENT NO.	Q/M
				7 / 83

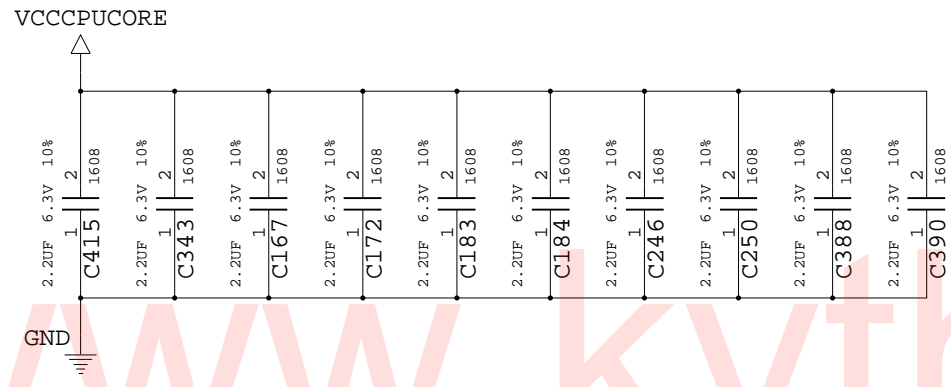

2.2UF X5R 1608 1/16W X15PCS

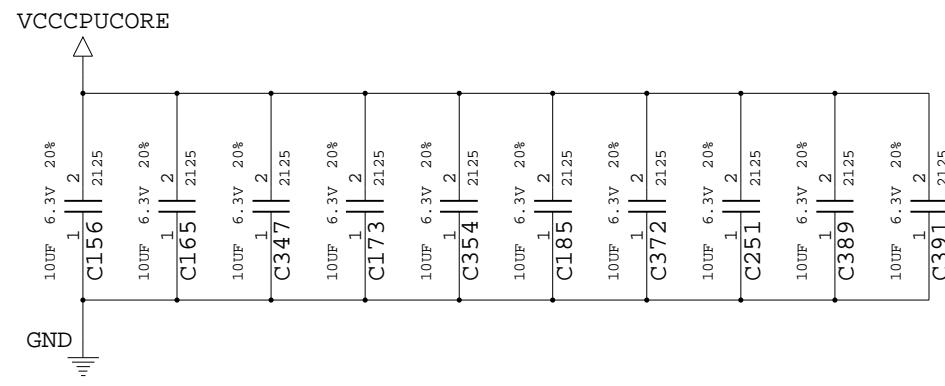
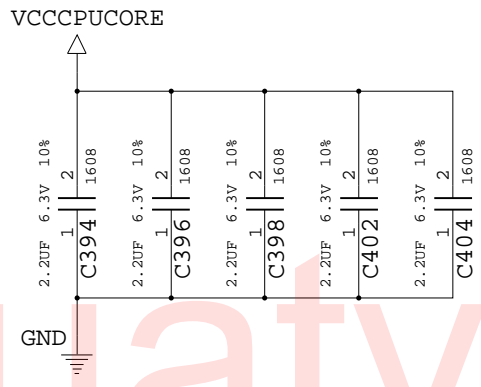

10UF X5R 2125 1/16W X16PCS

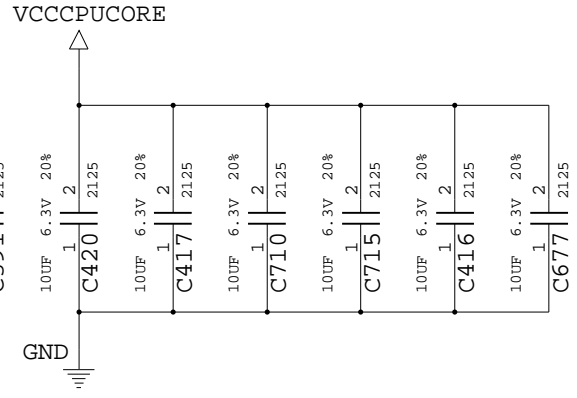

13R1439

DESIGNER	Y.I	08/03/04	PART NO.	13R1439	
CHECKED	Y.Y	08/03/04			
APPROVED	K.T	08/03/04	TITLE ROME-3.5 AP13 (V070)		
CLASS	K.T	08/03/04	VCCCPUCORE DECOUPLING		
THIS DOCUMENT IS THE PROPERTY OF IBM. ITS USE IS AUTHORIZED ONLY FOR RESPONDING TO A REQUEST FOR QUOTATION OR FOR THE PERFORMANCE OF WORK FOR IBM. ALL QUESTIONS MUST BE REFERRED TO THE IBM PURCHASING DEPARTMENT.				IBM CONFIDENTIAL	

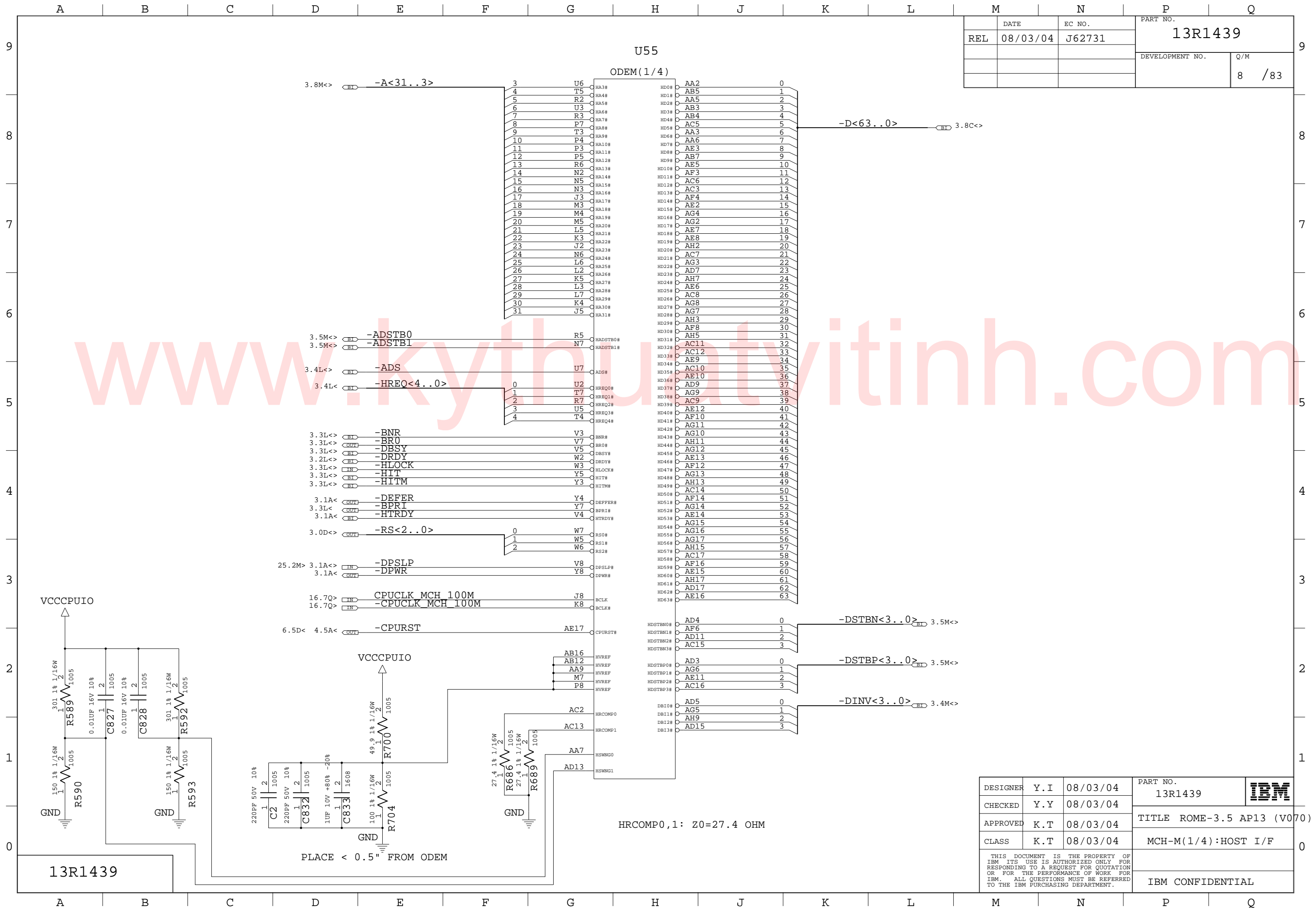

REL	DATE	EC NO.	PART NO.	
	08/03/04	J62731	13R1439	
			DEVELOPMENT NO.	Q/M
				8 / 83

DESIGNER	Y.I	08/03/04	PART NO.	13R1439	IBM
CHECKED	Y.Y	08/03/04			
APPROVED	K.T	08/03/04	TITLE ROME-3.5 AP13 (V070)		
CLASS	K.T	08/03/04	MCH-M(1/4):HOST I/F		
THIS DOCUMENT IS THE PROPERTY OF IBM. ITS USE IS AUTHORIZED ONLY FOR RESPONDING TO A REQUEST FOR QUOTATION OR FOR THE PERFORMANCE OF WORK FOR IBM. ALL QUESTIONS MUST BE REFERRED TO THE IBM PURCHASING DEPARTMENT.					
IBM CONFIDENTIAL					



DATE	EC NO.	PART NO.	
REL 08/03/04	J62731	13R1439	
		DEVELOPMENT NO.	Q/M
			9 / 83

U55  
ODEM(2/4)

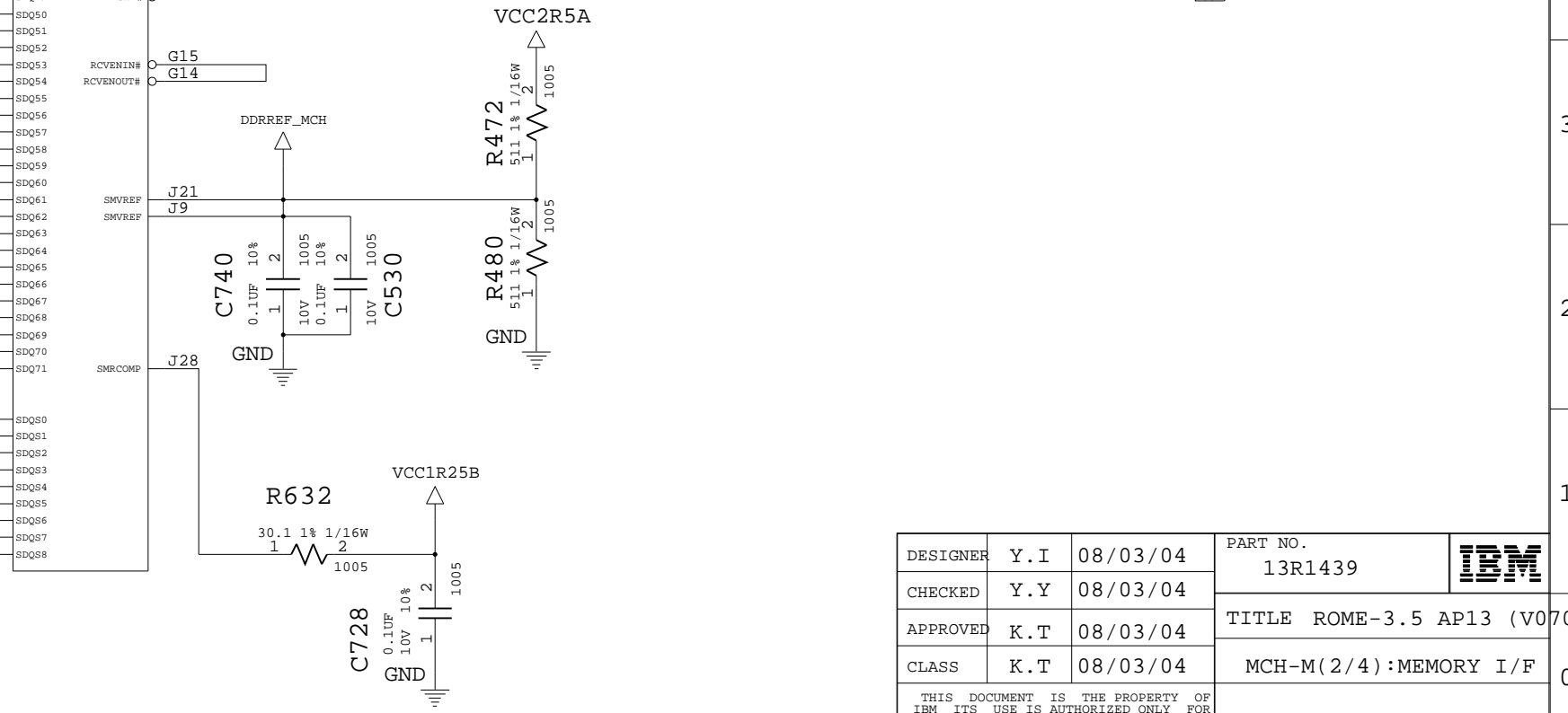
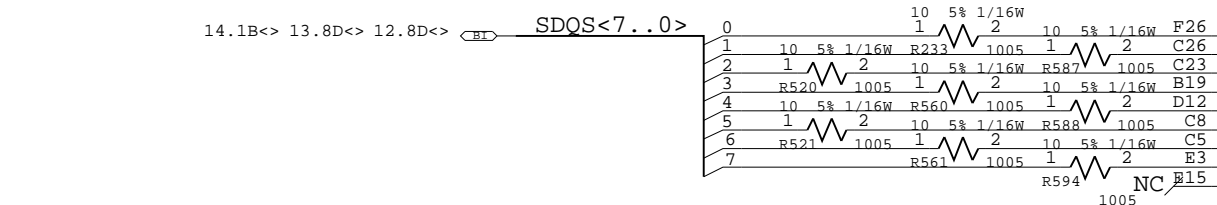
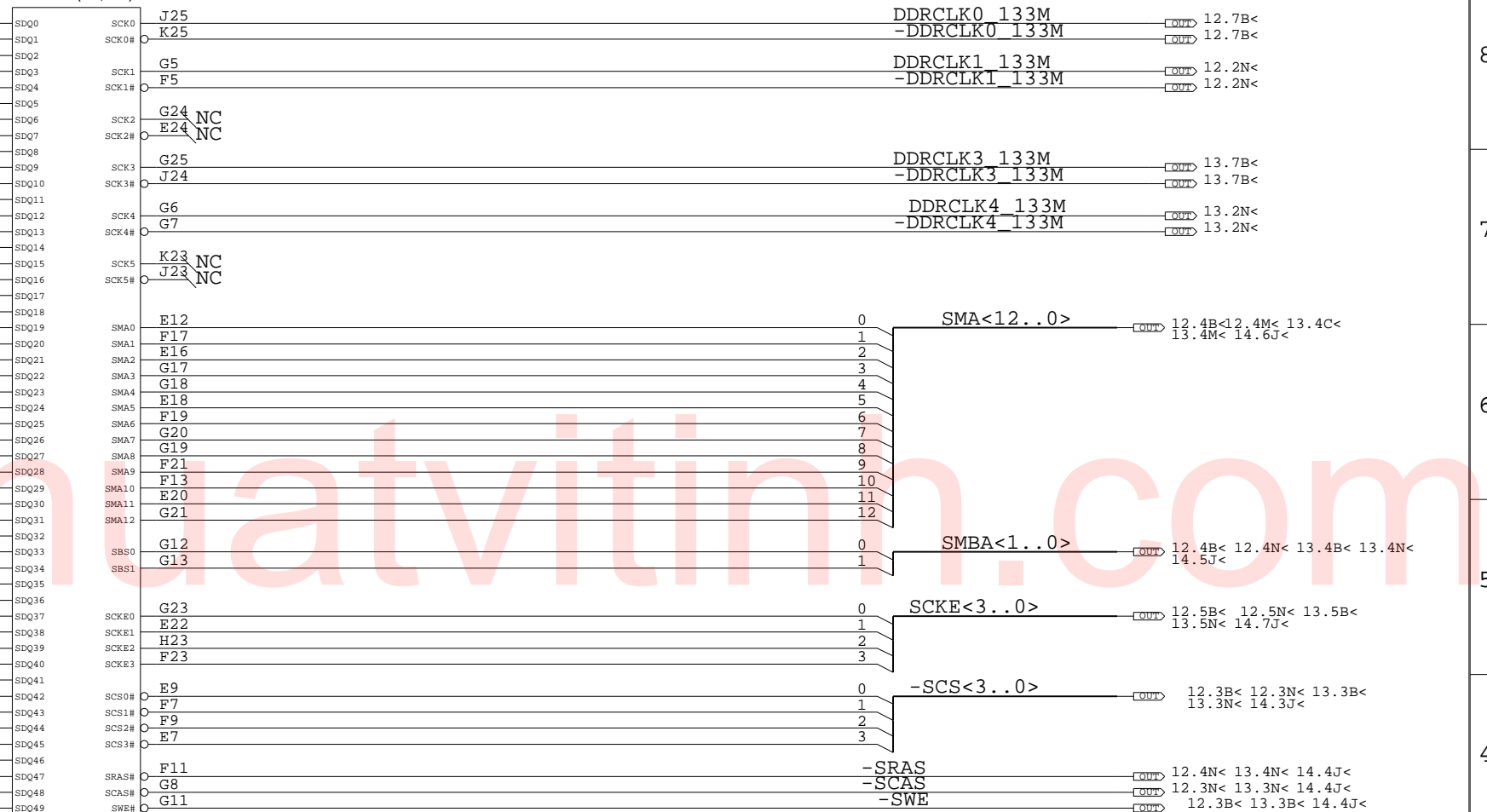
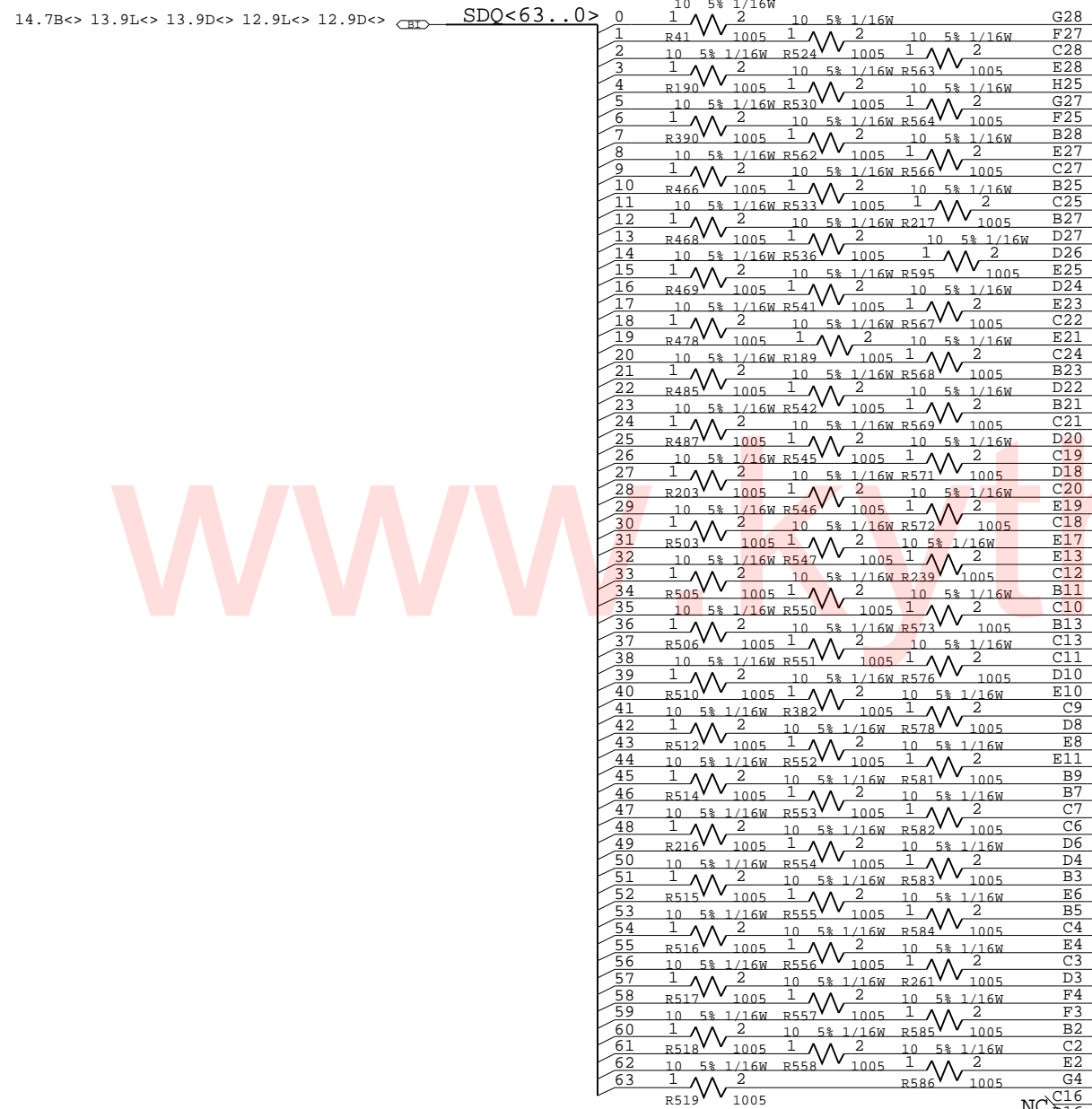

DESIGNER	Y.I	08/03/04	PART NO.	13R1439	
CHECKED	Y.Y	08/03/04			
APPROVED	K.T	08/03/04	TITLE ROME-3.5 AP13 (V070)		
CLASS	K.T	08/03/04	MCH-M(2/4):MEMORY I/F		
THIS DOCUMENT IS THE PROPERTY OF IBM. ITS USE IS AUTHORIZED ONLY FOR RESPONDING TO A REQUEST FOR QUOTATION OR FOR THE PERFORMANCE OF WORK FOR IBM. ALL QUESTIONS MUST BE REFERRED TO THE IBM PURCHASING DEPARTMENT.					IBM CONFIDENTIAL

13R1439

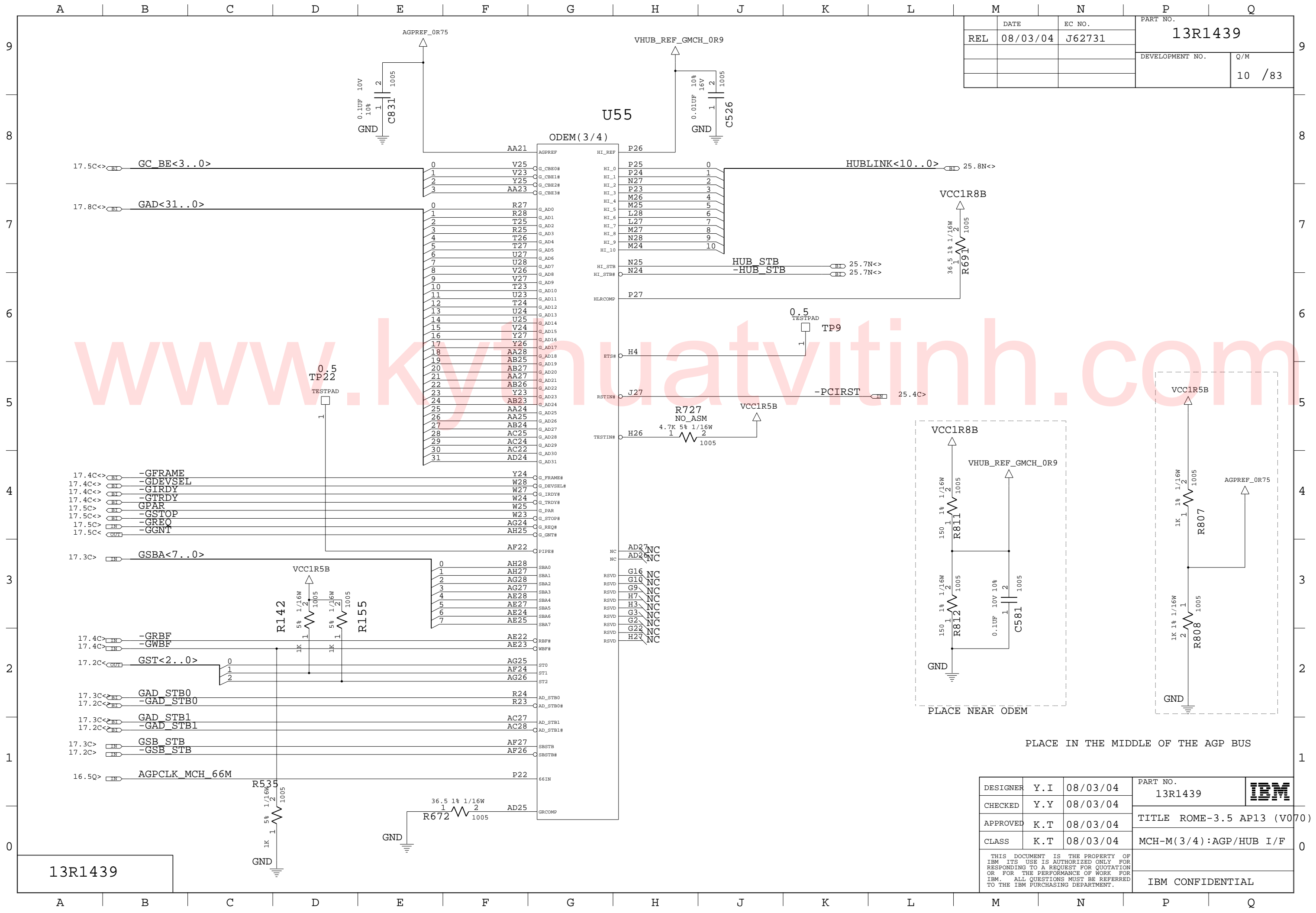

REL	DATE	EC NO.	PART NO.
	08/03/04	J62731	13R1439
			DEVELOPMENT NO.
			Q/M
			10 / 83

13R1439

DESIGNER	Y.I	08/03/04	PART NO.	13R1439	
CHECKED	Y.Y	08/03/04	TITLE		
APPROVED	K.T	08/03/04	CLASS	MCH-M(3/4):AGP/HUB I/F	IBM CONFIDENTIAL
<small>THIS DOCUMENT IS THE PROPERTY OF IBM. ITS USE IS AUTHORIZED ONLY FOR RESPONDING TO A REQUEST FOR QUOTATION OR FOR THE PERFORMANCE OF WORK FOR IBM. ALL QUESTIONS MUST BE REFERRED TO THE IBM PURCHASING DEPARTMENT.</small>					

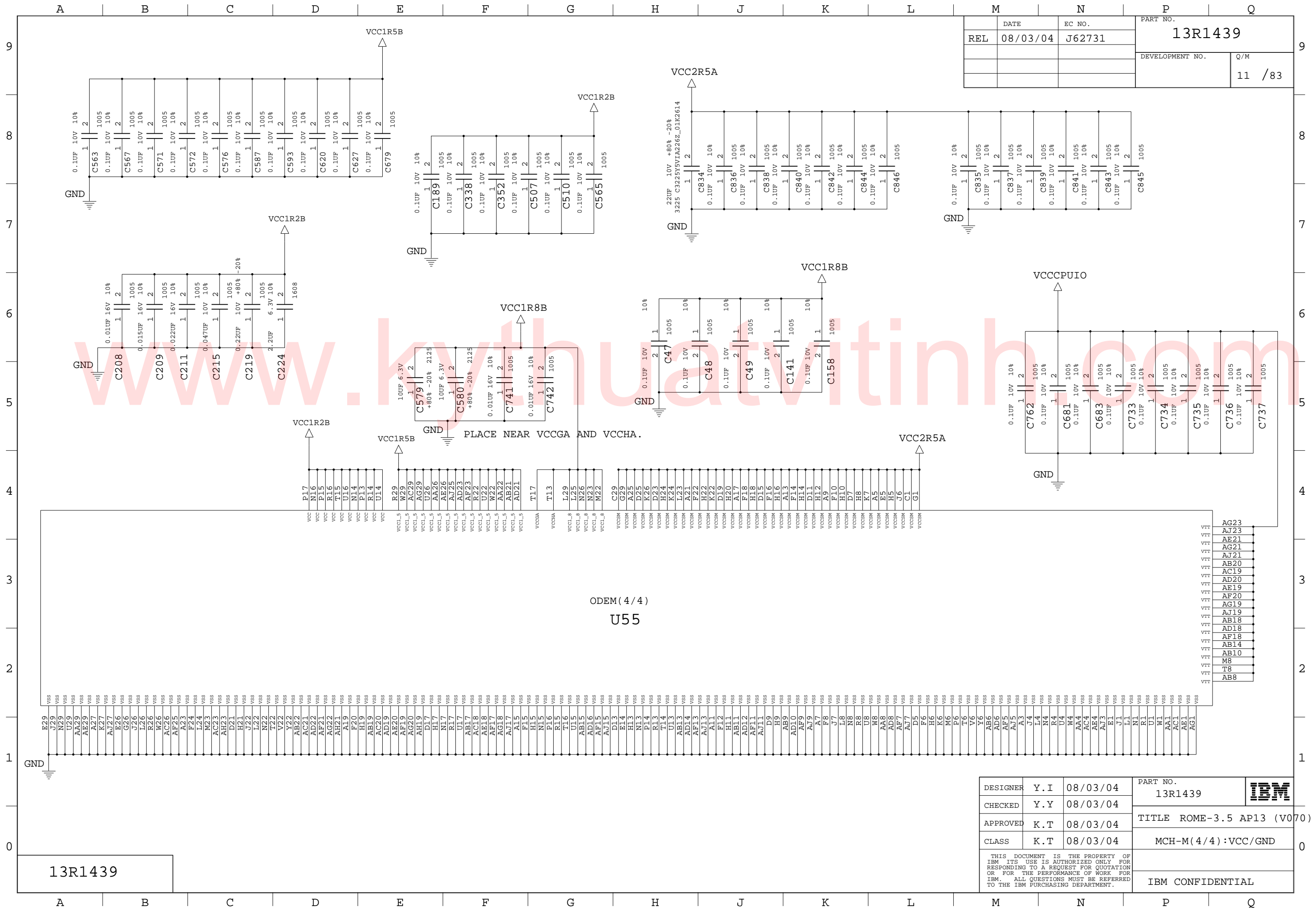

REL	DATE	EC NO.	PART NO.	
	08/03/04	J62731	13R1439	
			DEVELOPMENT NO.	Q/M
				11 / 83

13R1439

ODEM (4 / 4)  
U55

DESIGNER	Y. I	08/03/04	PART NO.	13R1439	
CHECKED	Y. Y	08/03/04	TITLE		
APPROVED	K. T	08/03/04	MCH-M(4/4):VCC/GND		
CLASS	K. T	08/03/04	IBM CONFIDENTIAL		

THIS DOCUMENT IS THE PROPERTY OF IBM. ITS USE IS AUTHORIZED ONLY FOR RESPONDING TO A REQUEST FOR QUOTATION OR FOR THE PERFORMANCE OF WORK FOR IBM. ALL QUESTIONS MUST BE REFERRED TO THE IBM PURCHASING DEPARTMENT.

- VTT AG23
- VTT AJ23
- VTT AE21
- VTT AG21
- VTT AJ21
- VTT AB20
- VTT AC19
- VTT AD20
- VTT AB19
- VTT AF20
- VTT AG19
- VTT AJ19
- VTT AB18
- VTT AD18
- VTT AF18
- VTT AB14
- VTT AB10
- VTT M8
- VTT T8
- VTT AB8

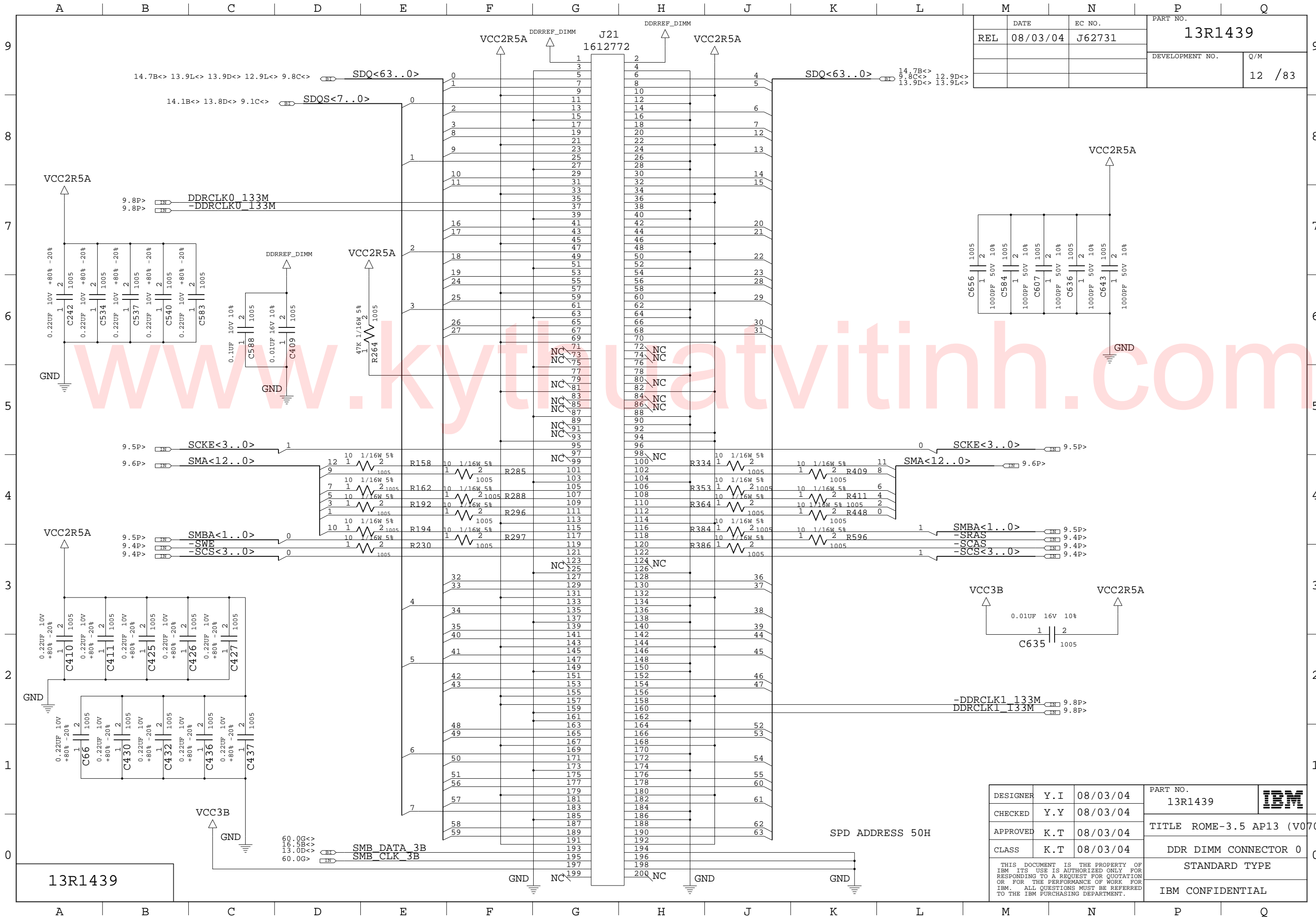

REL	DATE	EC NO.	PART NO.
	08/03/04	J62731	13R1439
			DEVELOPMENT NO.
			Q/M
			12 / 83

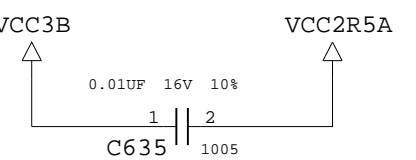
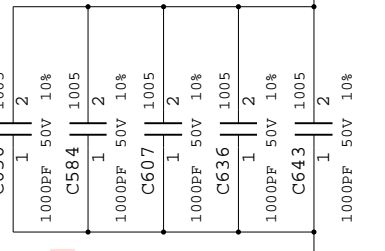

DESIGNER	Y.I	08/03/04	PART NO.	13R1439	
CHECKED	Y.Y	08/03/04	TITLE		
APPROVED	K.T	08/03/04	CLASS	DDR DIMM CONNECTOR 0	STANDARD TYPE
				IBM CONFIDENTIAL	
THIS DOCUMENT IS THE PROPERTY OF IBM. ITS USE IS AUTHORIZED ONLY FOR RESPONDING TO A REQUEST FOR QUOTATION OR FOR THE PERFORMANCE OF WORK FOR IBM. ALL QUESTIONS MUST BE REFERRED TO THE IBM PURCHASING DEPARTMENT.					

13R1439

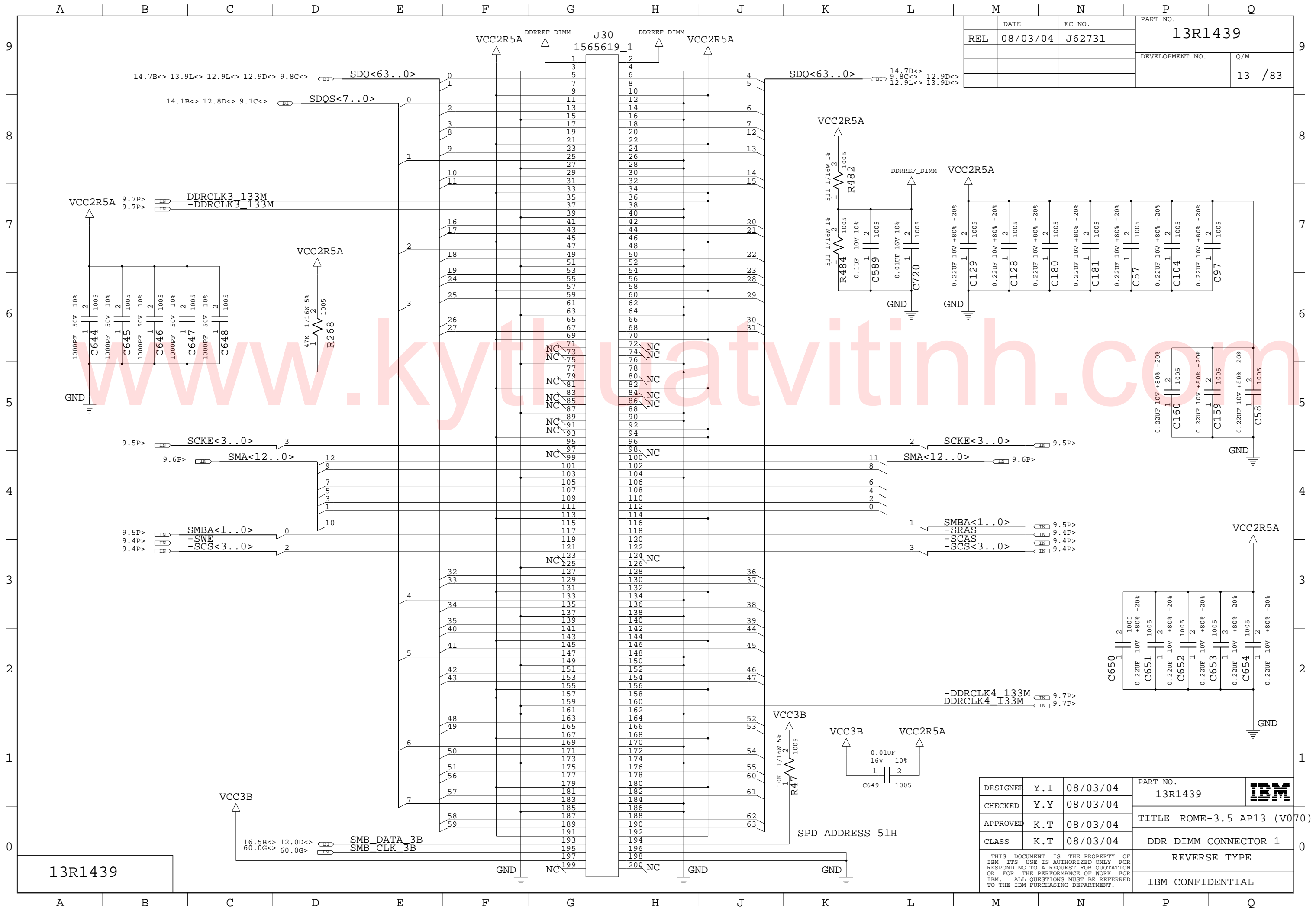

REL	DATE	EC NO.	PART NO.
	08/03/04	J62731	13R1439
			DEVELOPMENT NO.
			Q/M
			13 / 83

13R1439

DESIGNER	Y.I	08/03/04	PART NO.	13R1439	
CHECKED	Y.Y	08/03/04			
APPROVED	K.T	08/03/04	TITLE ROME-3.5 AP13 (V070)		
CLASS	K.T	08/03/04	DDR DIMM CONNECTOR 1		
THIS DOCUMENT IS THE PROPERTY OF IBM. ITS USE IS AUTHORIZED ONLY FOR RESPONDING TO A REQUEST FOR QUOTATION OR FOR THE PERFORMANCE OF WORK FOR IBM. ALL QUESTIONS MUST BE REFERRED TO THE IBM PURCHASING DEPARTMENT.					REVERSE TYPE
					IBM CONFIDENTIAL

DATE		EC NO.		PART NO.	
REL	08/03/04	J62731		13R1439	
DEVELOPMENT NO.				Q/M	
				14 /83	

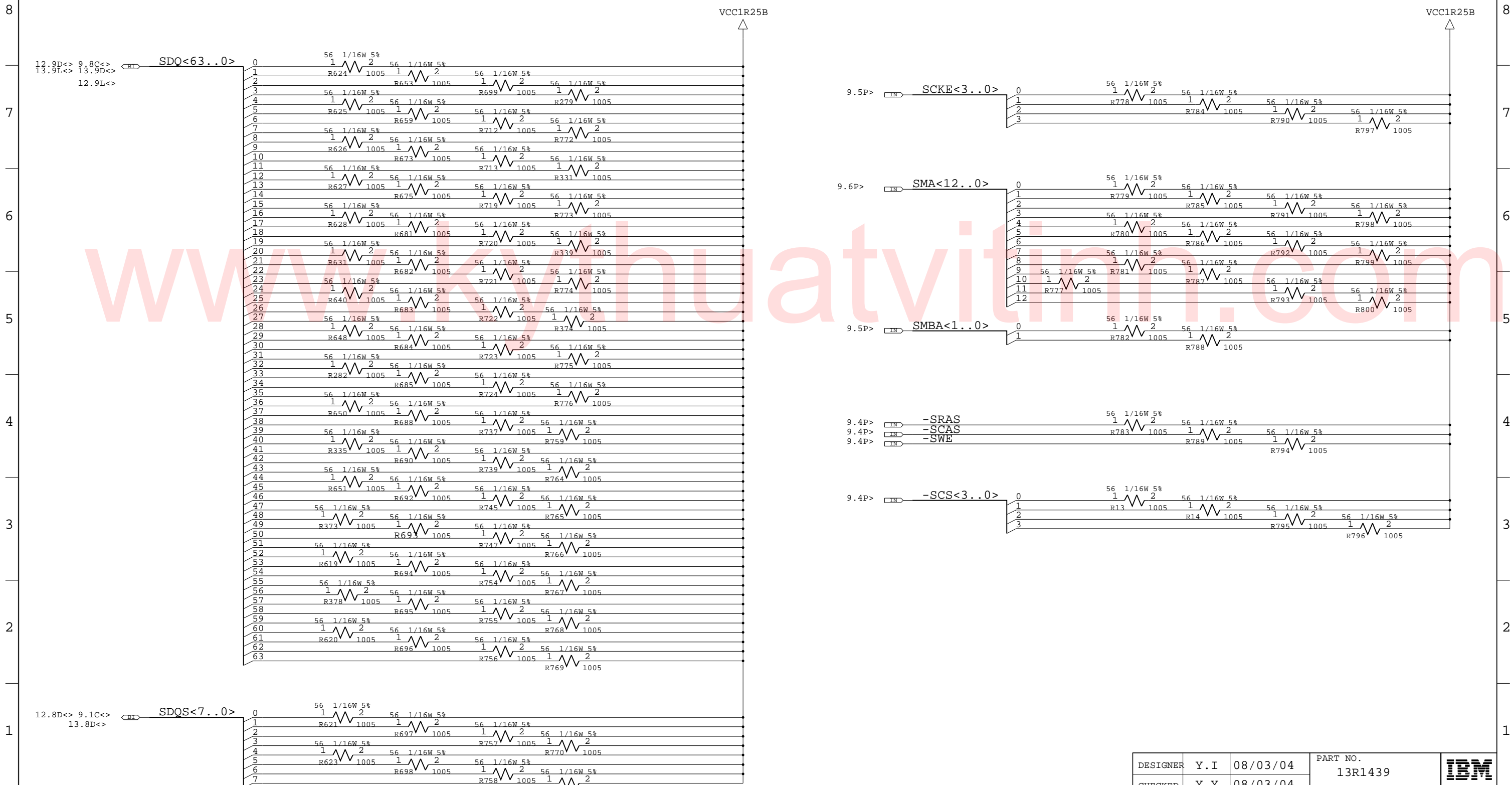

13R1439

DESIGNER	Y.I	08/03/04	PART NO.	IBM
CHECKED	Y.Y	08/03/04	13R1439	
APPROVED	K.T	08/03/04	TITLE ROME-3.5 AP13 (V070)	
CLASS	K.T	08/03/04	SSTL-2 TERMINATION	
THIS DOCUMENT IS THE PROPERTY OF IBM. ITS USE IS AUTHORIZED ONLY FOR RESPONDING TO A REQUEST FOR QUOTATION OR FOR THE PERFORMANCE OF WORK FOR IBM. ALL QUESTIONS MUST BE REFERRED TO THE IBM PURCHASING DEPARTMENT.				IBM CONFIDENTIAL

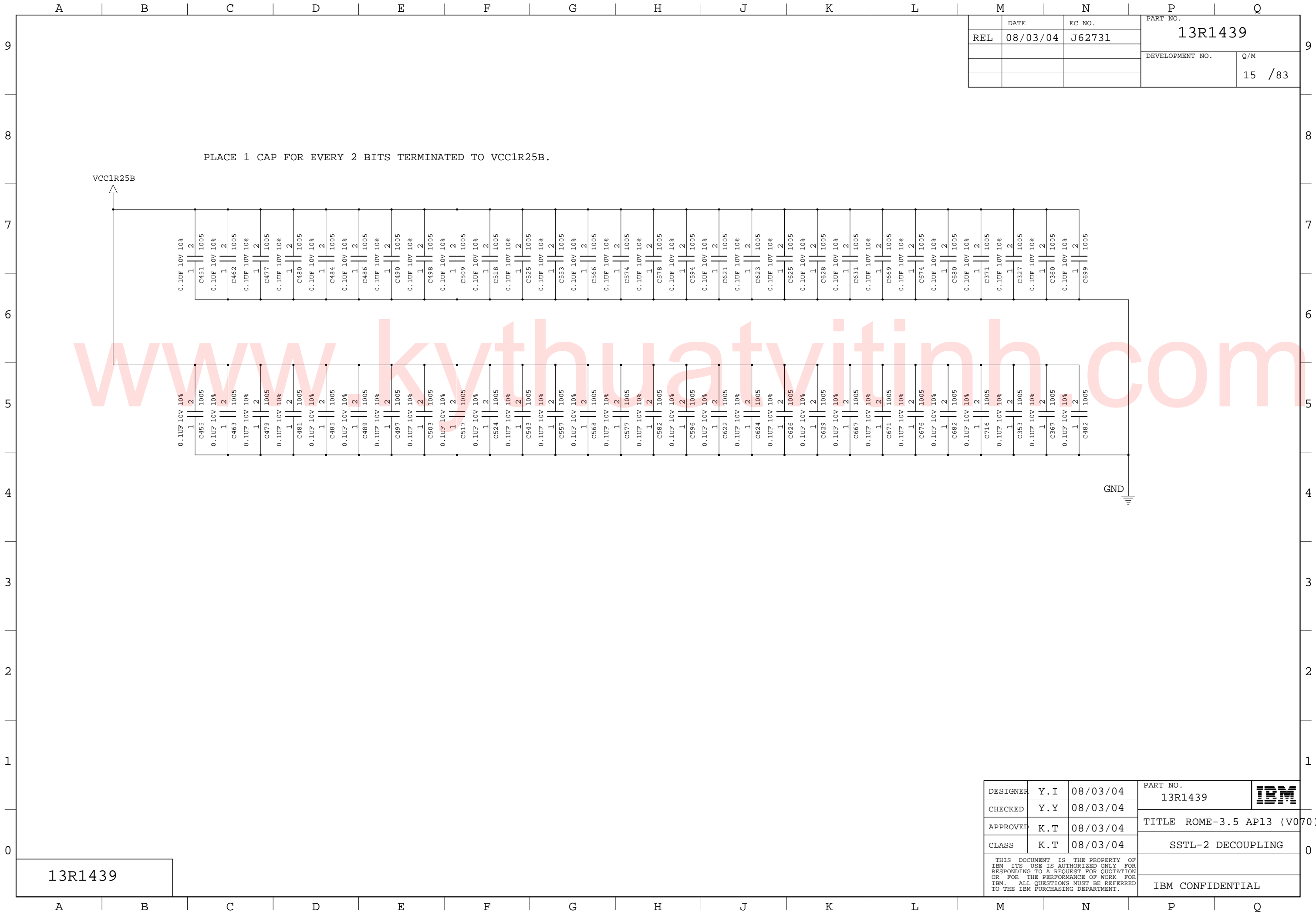

	DATE	EC NO.	PART NO.	
REL	08/03/04	J62731	13R1439	
			DEVELOPMENT NO.	Q/M
				15 /83

13R1439

DESIGNER	Y.I	08/03/04	PART NO.	13R1439	
CHECKED	Y.Y	08/03/04	TITLE		
APPROVED	K.T	08/03/04	SSTL-2 DECOUPLING		
CLASS	K.T	08/03/04	IBM CONFIDENTIAL		

THIS DOCUMENT IS THE PROPERTY OF IBM. ITS USE IS AUTHORIZED ONLY FOR RESPONDING TO A REQUEST FOR QUOTATION OR FOR THE PERFORMANCE OF WORK FOR IBM. ALL QUESTIONS MUST BE REFERRED TO THE IBM PURCHASING DEPARTMENT.

DATE	EC NO.	PART NO.	
REL 08/03/04	J62731	13R1439	
		DEVELOPMENT NO.	Q/M
			16 / 83

SEL1	SEL0	CPU
0	0	66M
0	1	100M
1	0	200M
1	1	133M

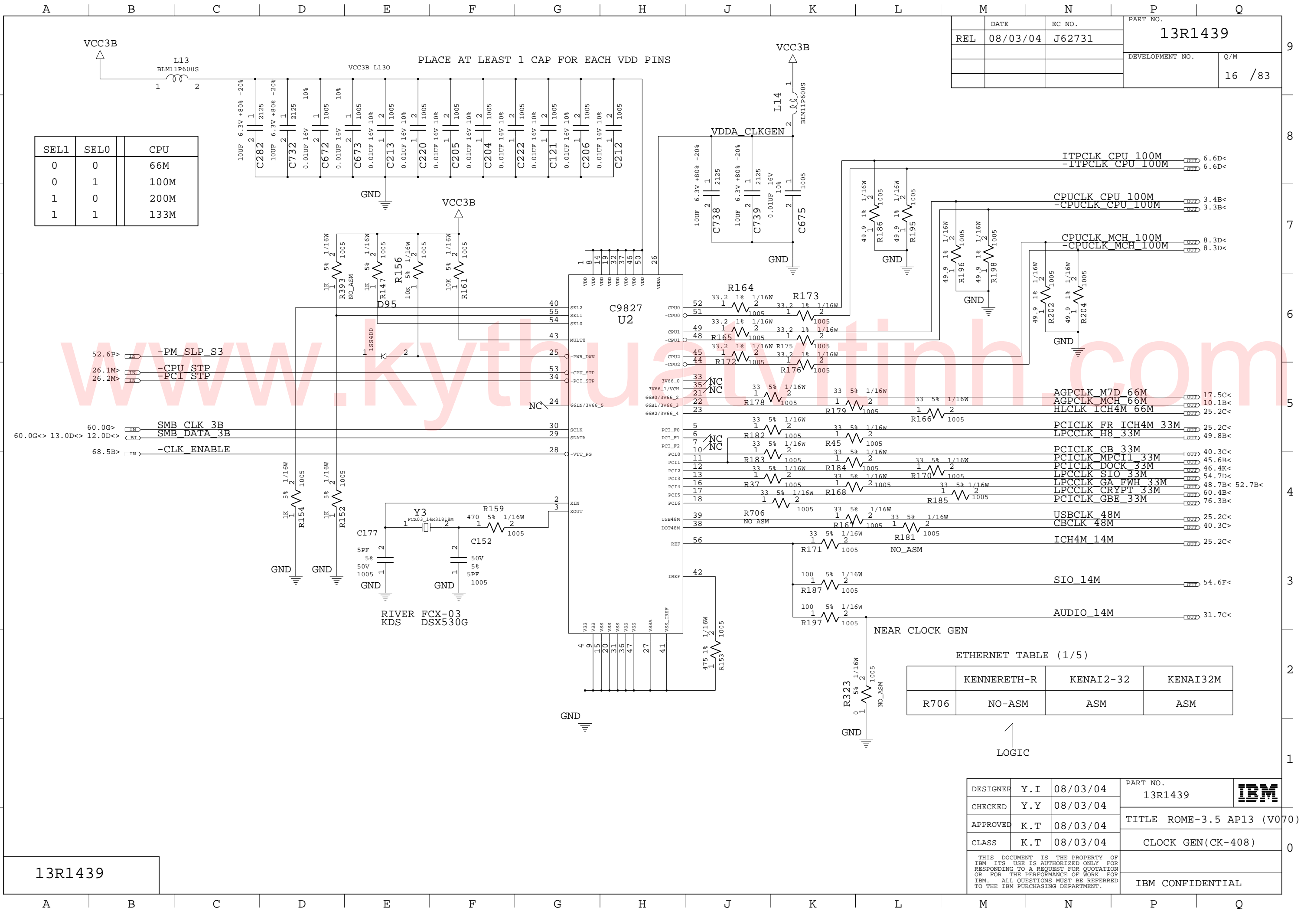

www.kyrtinh.com

ETHERNET TABLE (1/5)

	KENNERETH-R	KENAI2-32	KENAI32M
R706	NO-ASM	ASM	ASM

DESIGNER	Y.I	08/03/04	PART NO.	13R1439	
CHECKED	Y.Y	08/03/04	TITLE ROME-3.5 AP13 (V070)		
APPROVED	K.T	08/03/04	CLOCK GEN(CK-408)		
CLASS	K.T	08/03/04	IBM CONFIDENTIAL		

THIS DOCUMENT IS THE PROPERTY OF IBM. ITS USE IS AUTHORIZED ONLY FOR RESPONDING TO A REQUEST FOR QUOTATION OR FOR THE PERFORMANCE OF WORK FOR IBM. ALL QUESTIONS MUST BE REFERRED TO THE IBM PURCHASING DEPARTMENT.

13R1439





REL	DATE	EC NO.	PART NO.	
	08/03/04	J62731	13R1439	
			DEVELOPMENT NO.	Q/M
				18 /83

# U47

M10\_CSP64\_56G (2/7)

ATI TABLE 2/7

	M6	M7	M9/M9+/M10
R481	NO-ASM	ASM	ASM
R464	NO-ASM	ASM	ASM
R54	ASM	NO-ASM	NO-ASM
R494	ASM	NO-ASM	NO-ASM
R896	NO-ASM	ASM	ASM
R897	NO-ASM	ASM	ASM

LOGIC

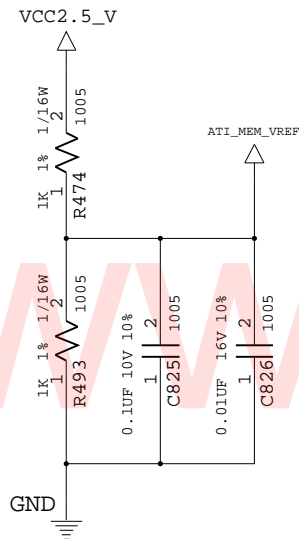

	M7/M9	M10
C381	ASM	NO-ASM
C408	ASM	NO-ASM

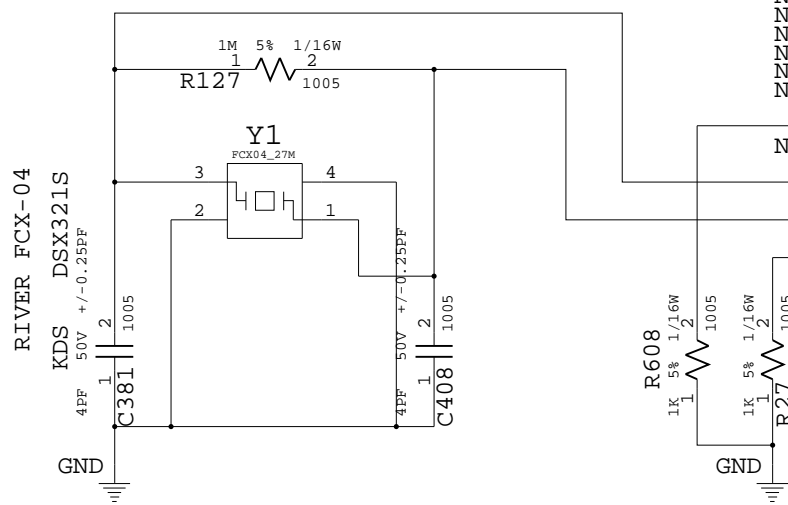

NEAR VIDEO CHIP

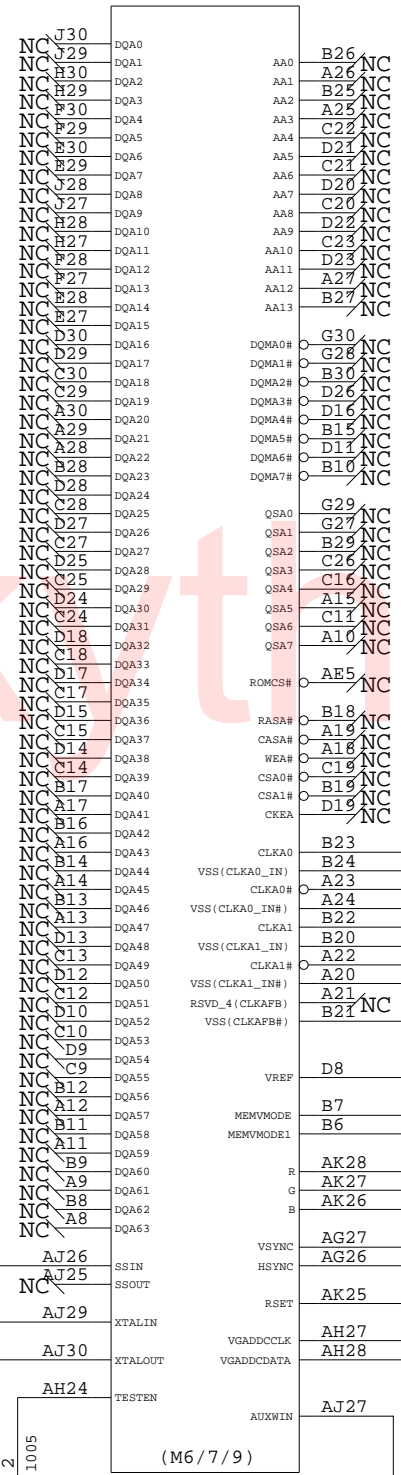

	DATE	EC NO.	PART NO.	
REL	08/03/04	J62731	13R1439	
			DEVELOPMENT NO.	Q/M
				19 /83

# U47

M10\_CSP64\_56G (3/7)

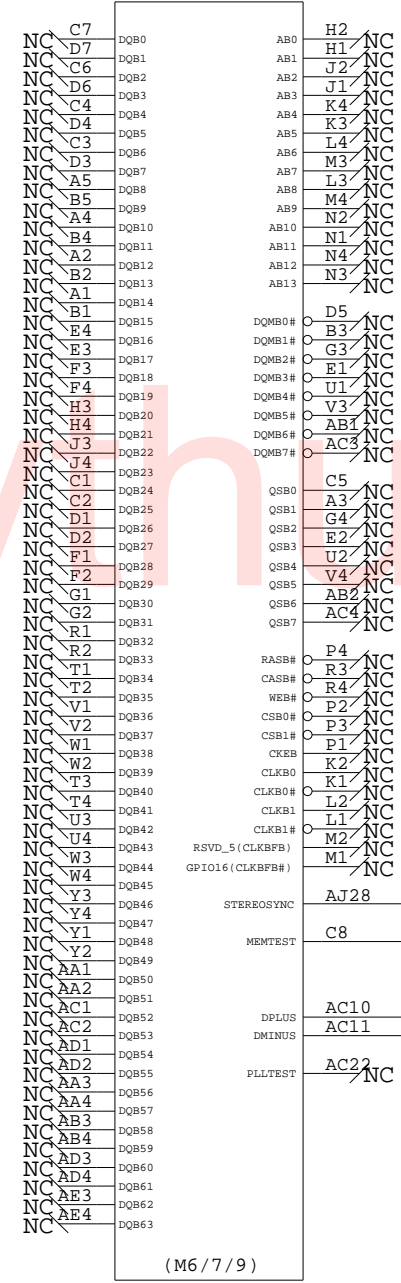

www.kyngiatvithinh.com

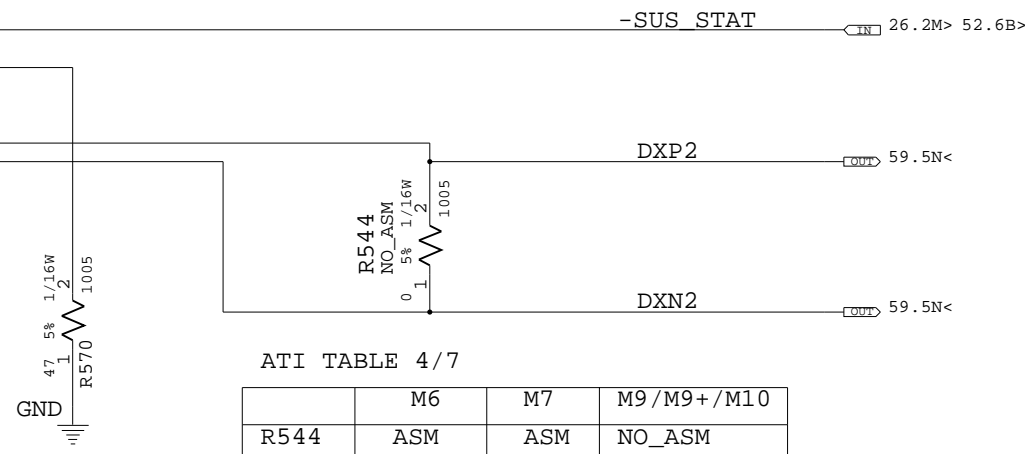

ATI TABLE 4/7

	M6	M7	M9/M9+/M10
R544	ASM	ASM	NO_ASM

LOGIC

13R1439

DESIGNER	Y.I	08/03/04	PART NO.	13R1439	
CHECKED	Y.Y	08/03/04			
APPROVED	K.T	08/03/04	TITLE ROME-3.5 AP13 (V070)		
CLASS	K.T	08/03/04	RADEON M9_CSP (3/7)		
THIS DOCUMENT IS THE PROPERTY OF IBM. ITS USE IS AUTHORIZED ONLY FOR RESPONDING TO A REQUEST FOR QUOTATION OR FOR THE PERFORMANCE OF WORK FOR IBM. ALL QUESTIONS MUST BE REFERRED TO THE IBM PURCHASING DEPARTMENT.				IBM CONFIDENTIAL	

DATE	EC NO.	PART NO.	
REL 08/03/04	J62731	13R1439	
		DEVELOPMENT NO.	Q/M
			20 / 83

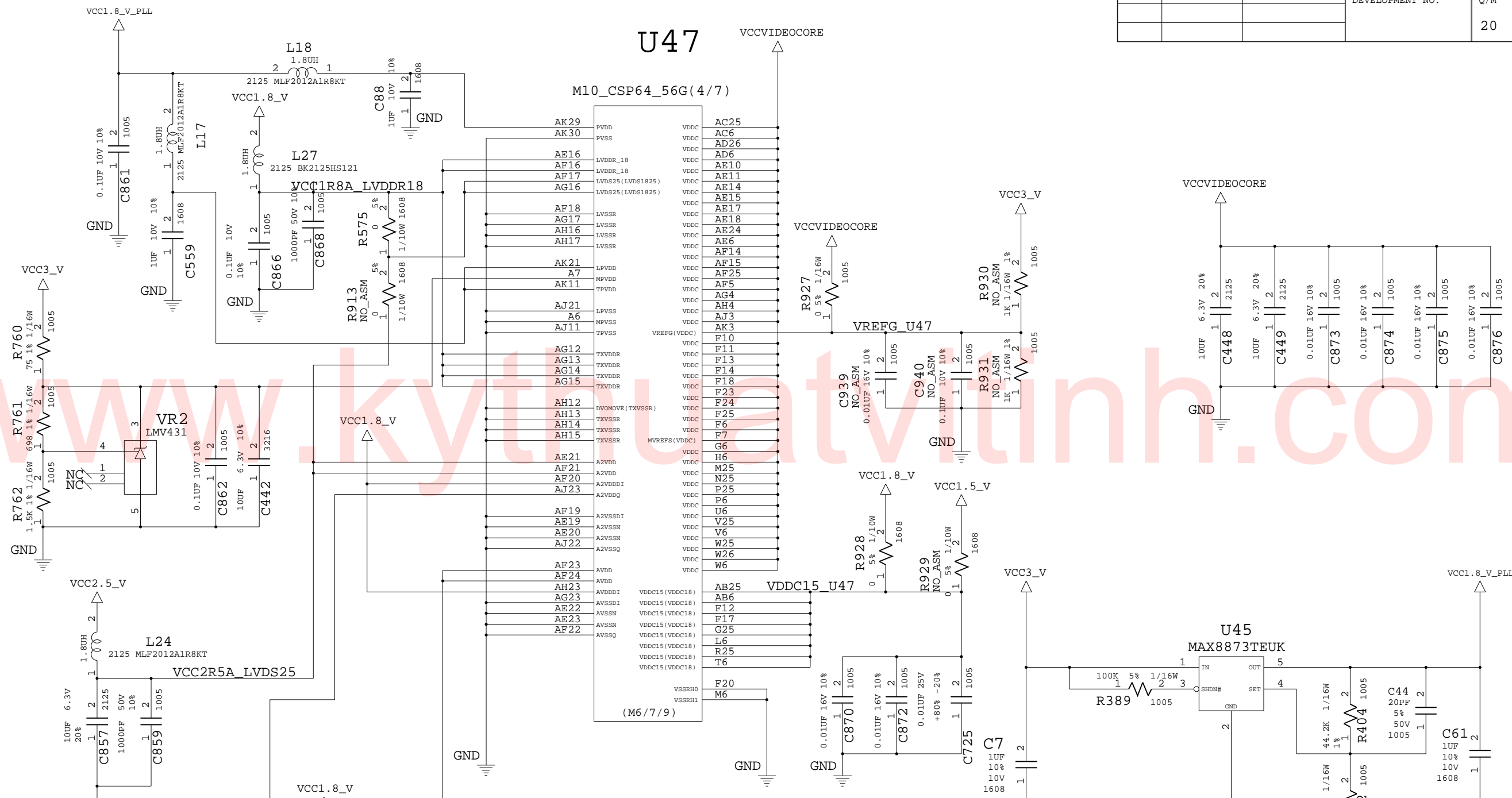

ATI TABLE 7/7

	M6/M7/M9/M9+	M10
R575	ASM	NO-ASM
R913	NO-ASM	ASM
R928	ASM	NO-ASM
R929	NO-ASM	ASM
R927	ASM	NO-ASM
R930	NO-ASM	ASM
R931	NO-ASM	ASM
C939	NO-ASM	ASM
C940	NO-ASM	ASM
L24	MLF2012A1R8KT	BK2125HS121
L27	BK2125HS121	MLF2012A1R8KT

LOGIC

DESIGNER	Y.I	08/03/04	PART NO.	13R1439	
CHECKED	Y.Y	08/03/04			
APPROVED	K.T	08/03/04	TITLE ROME-3.5 AP13 (V070)		
CLASS	K.T	08/03/04	RADEON M9_CSP (4/7)		
THIS DOCUMENT IS THE PROPERTY OF IBM. ITS USE IS AUTHORIZED ONLY FOR RESPONDING TO A REQUEST FOR QUOTATION OR FOR THE PERFORMANCE OF WORK FOR IBM. ALL QUESTIONS MUST BE REFERRED TO THE IBM PURCHASING DEPARTMENT.					IBM CONFIDENTIAL

13R1439

	DATE	EC NO.	PART NO.	
REL	08/03/04	J62731	13R1439	
			DEVELOPMENT NO.	Q/M
				21 / 83

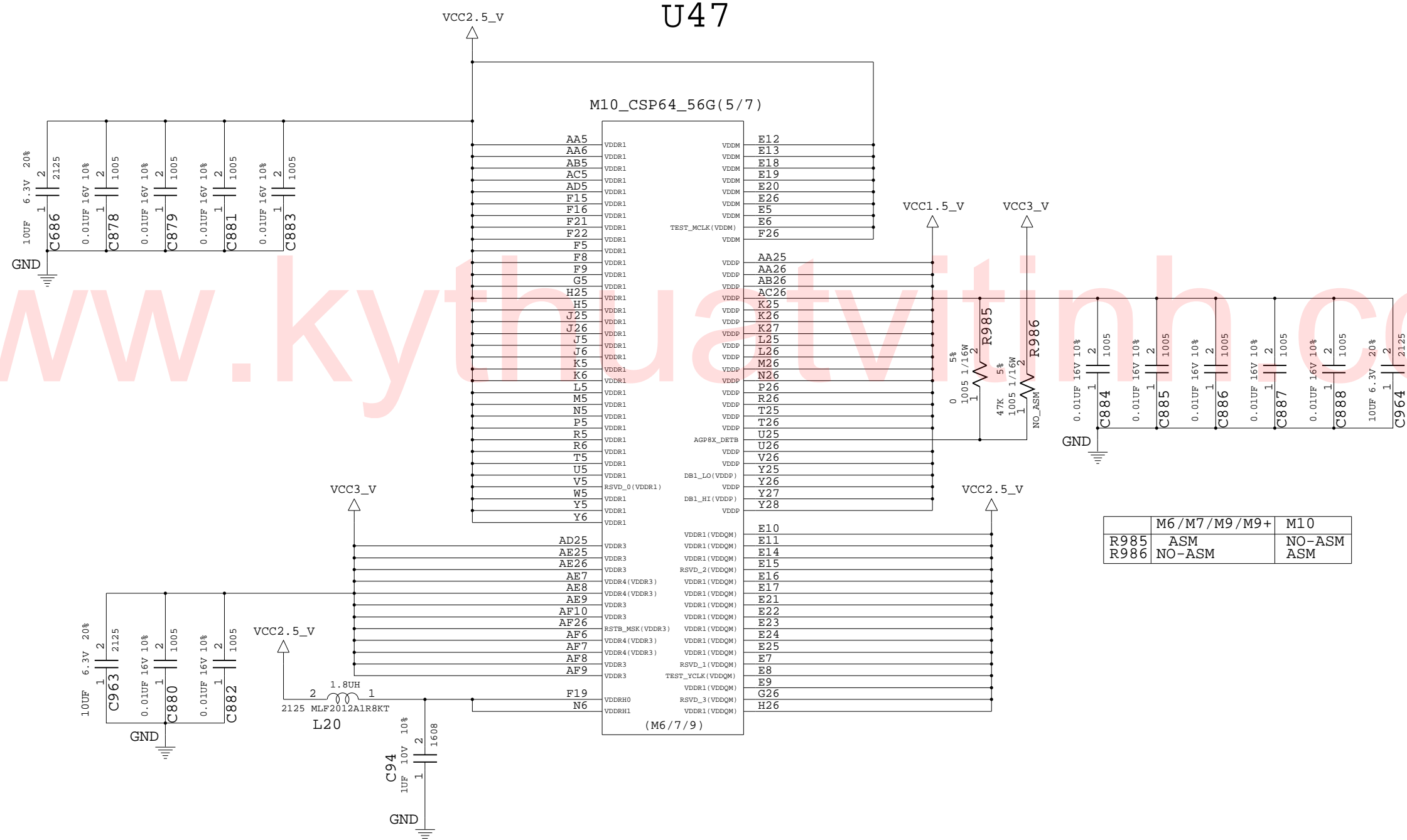

	M6/M7/M9/M9+	M10
R985	ASM	NO-ASM
R986	NO-ASM	ASM

13R1439

DESIGNER	Y.I	08/03/04	PART NO.	13R1439	
CHECKED	Y.Y	08/03/04			
APPROVED	K.T	08/03/04	TITLE ROME-3.5 AP13 (V070)		
CLASS	K.T	08/03/04	RADEON M9_CSP (5/7)		
THIS DOCUMENT IS THE PROPERTY OF IBM. ITS USE IS AUTHORIZED ONLY FOR RESPONDING TO A REQUEST FOR QUOTATION OR FOR THE PERFORMANCE OF WORK FOR IBM. ALL QUESTIONS MUST BE REFERRED TO THE IBM PURCHASING DEPARTMENT.				IBM CONFIDENTIAL	

A B C D E F G H J K L M N P Q

REL	DATE 08/03/04	EC NO. J62731	PART NO. 13R1439	
			DEVELOPMENT NO.	Q/M 22 /83

U47

M10\_CSP64\_56G(6/7)

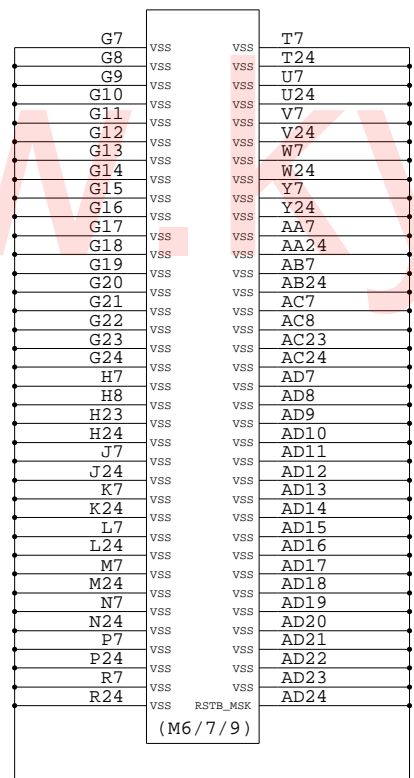

GND

U47

M10\_CSP64\_56G(7/7)

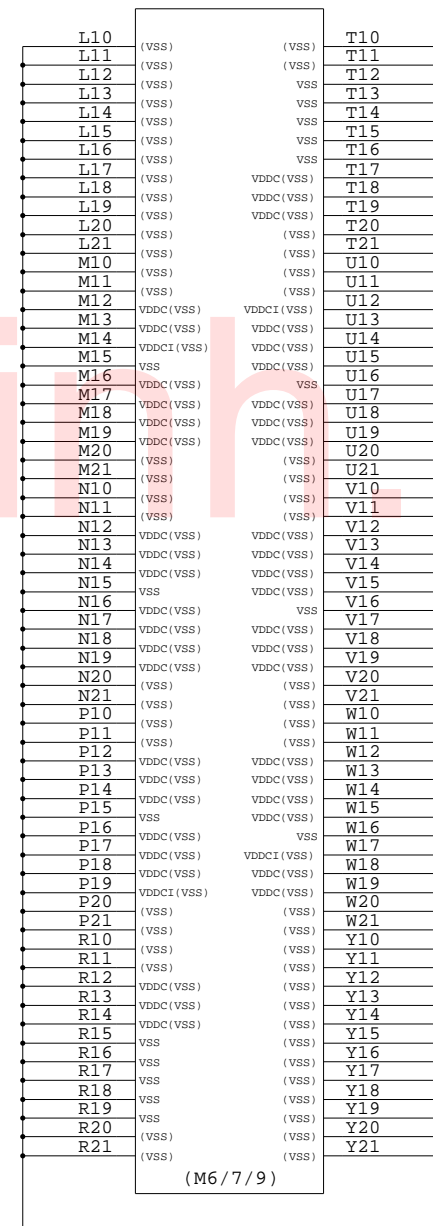

GND

13R1439

DESIGNER	Y. I	08/03/04	PART NO. 13R1439	<b>IBM</b>
CHECKED	Y. Y	08/03/04	TITLE ROME-3.5 AP13 (V070)	
APPROVED	K. T	08/03/04	RADEON M9_CSP (6/7 7/7)	
CLASS	K. T	08/03/04	IBM CONFIDENTIAL	

THIS DOCUMENT IS THE PROPERTY OF IBM. ITS USE IS AUTHORIZED ONLY FOR RESPONDING TO A REQUEST FOR QUOTATION OR FOR THE PERFORMANCE OF WORK FOR IBM. ALL QUESTIONS MUST BE REFERRED TO THE IBM PURCHASING DEPARTMENT.

A B C D E F G H J K L M N P Q

	DATE	EC NO.	PART NO.	
REL	08/03/04	J62731	13R1439	
			DEVELOPMENT NO.	Q/M
				23 /83

ASM PARTS FOR M10GL ONLY

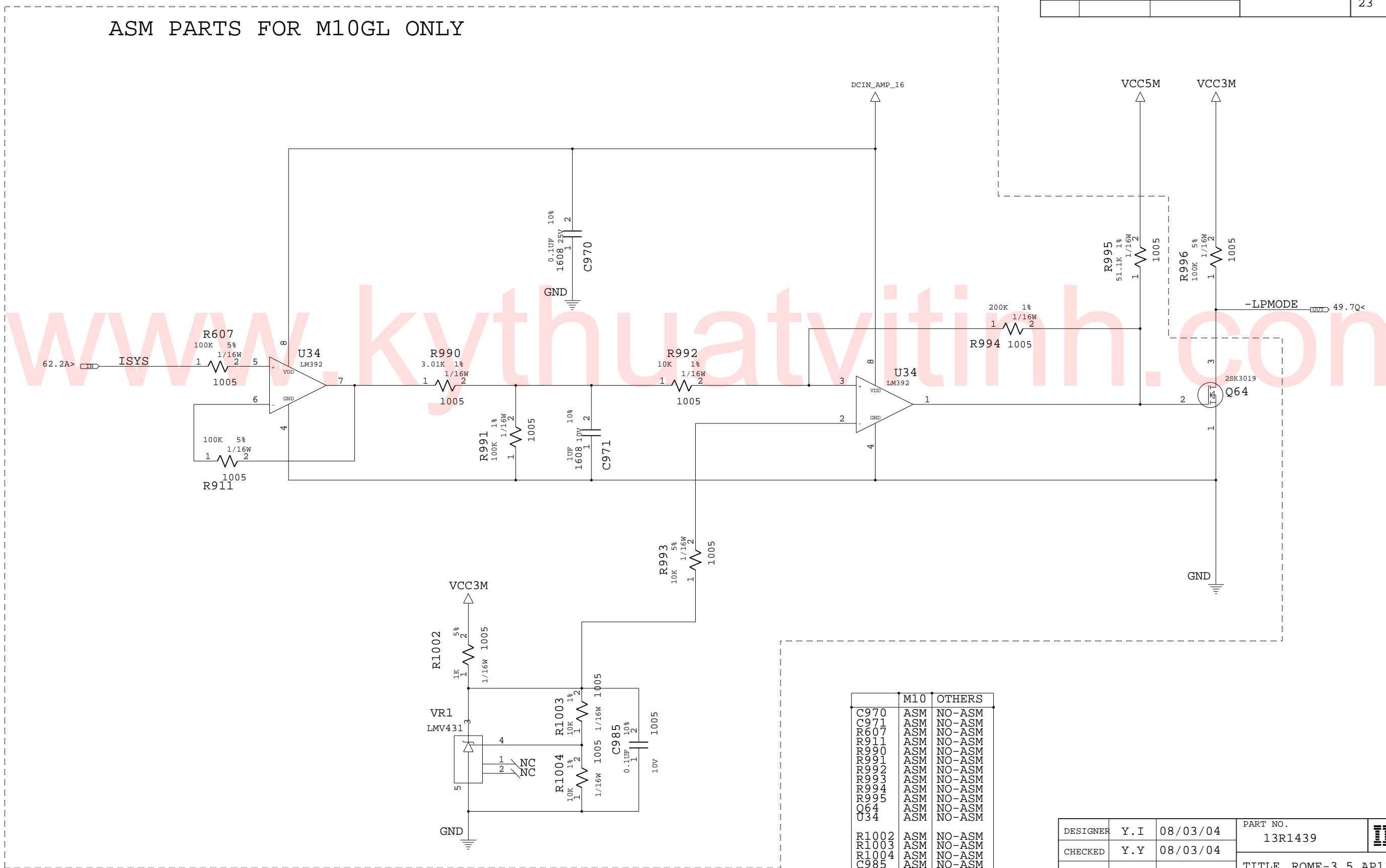

	M10	OTHERS
C970	ASM	NO-ASM
C971	ASM	NO-ASM
R607	ASM	NO-ASM
R911	ASM	NO-ASM
R990	ASM	NO-ASM
R991	ASM	NO-ASM
R992	ASM	NO-ASM
R993	ASM	NO-ASM
R994	ASM	NO-ASM
R995	ASM	NO-ASM
R996	ASM	NO-ASM
R1002	ASM	NO-ASM
R1003	ASM	NO-ASM
R1004	ASM	NO-ASM
C985	ASM	NO-ASM
Q64	ASM	NO-ASM
U34	ASM	NO-ASM

DESIGNER	Y.I	08/03/04	PART NO.	13R1439	
CHECKED	Y.Y	08/03/04			
APPROVED	K.T	08/03/04	TITLE ROME-3.5 AP13 (V070)		
CLASS	K.T	08/03/04	DC/DC MAX PWR CTRL		
THIS DOCUMENT IS THE PROPERTY OF IBM. ITS USE IS AUTHORIZED ONLY FOR RESPONDING TO A REQUEST FOR QUOTATION OR FOR THE PERFORMANCE OF WORK FOR IBM. ALL QUESTIONS MUST BE REFERRED TO THE IBM PURCHASING DEPARTMENT.					IBM CONFIDENTIAL

13R1439

REL	DATE	EC NO.	PART NO.
	08/03/04	J62731	13R1439
			DEVELOPMENT NO.
			Q/M
			24 /83

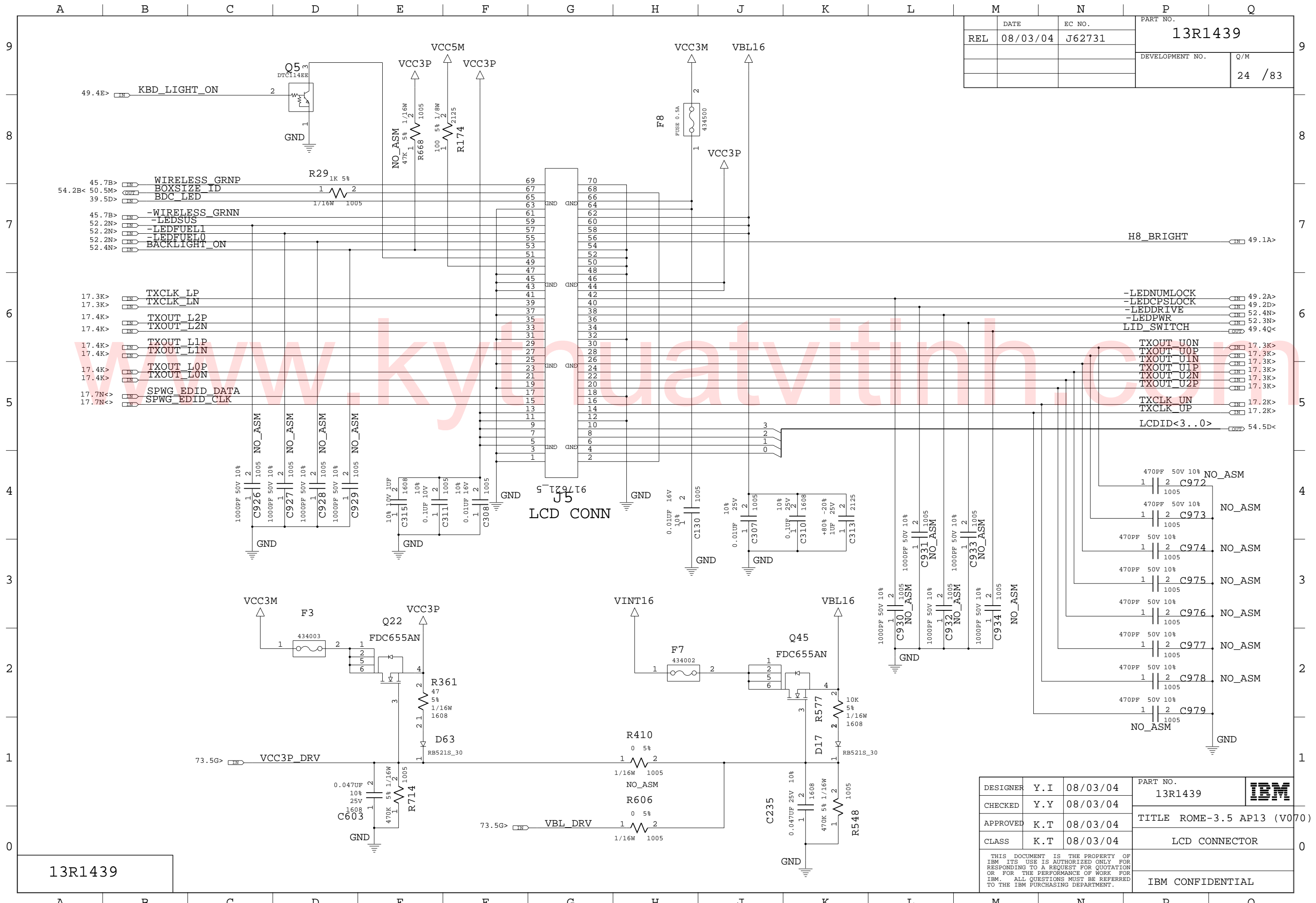

13R1439

DESIGNER	Y.I	08/03/04	PART NO.	13R1439	
CHECKED	Y.Y	08/03/04	TITLE		
APPROVED	K.T	08/03/04	LCD CONNECTOR		
CLASS	K.T	08/03/04	IBM CONFIDENTIAL		

THIS DOCUMENT IS THE PROPERTY OF IBM. ITS USE IS AUTHORIZED ONLY FOR RESPONDING TO A REQUEST FOR QUOTATION OR FOR THE PERFORMANCE OF WORK FOR IBM. ALL QUESTIONS MUST BE REFERRED TO THE IBM PURCHASING DEPARTMENT.





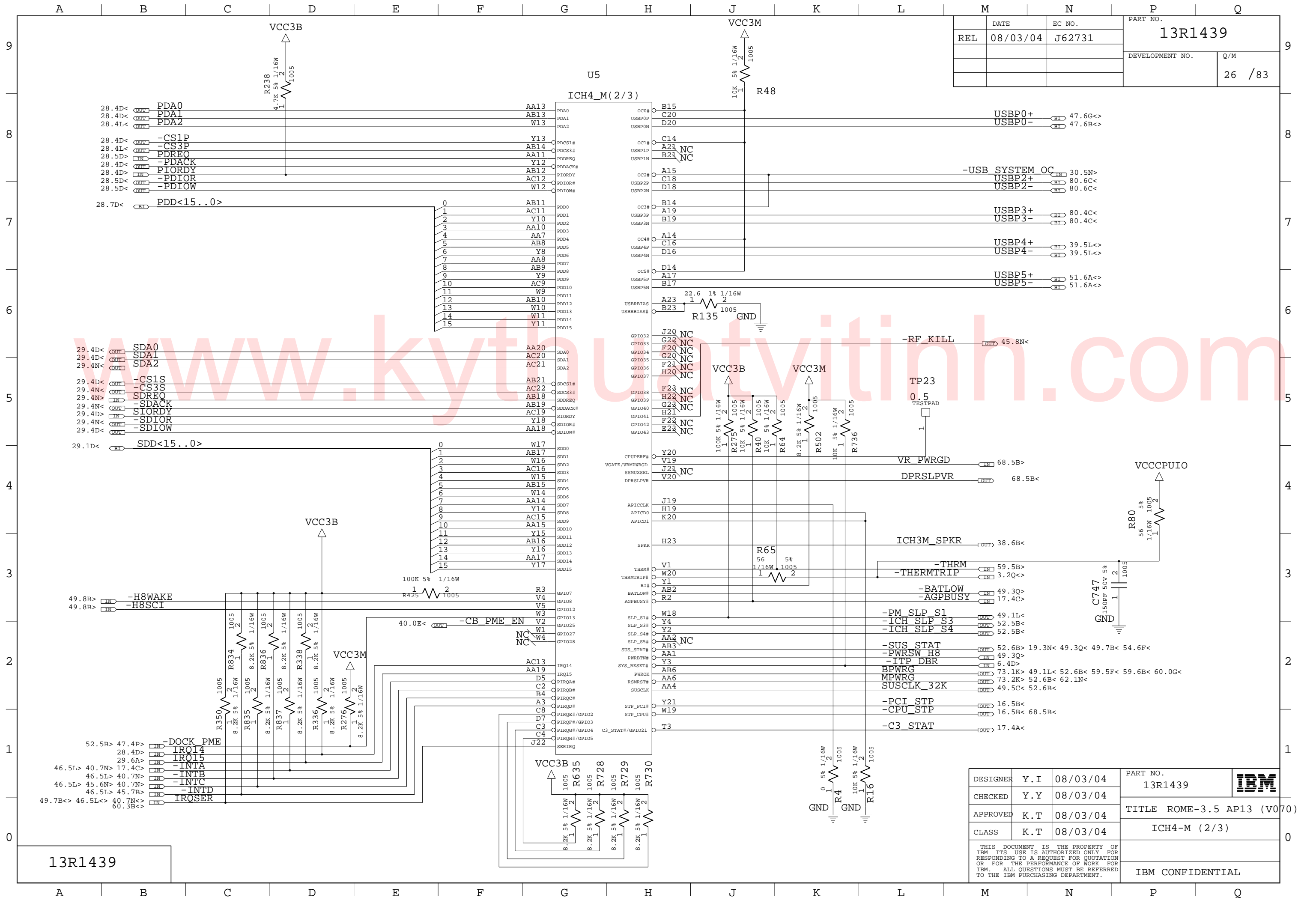

REL	DATE	EC NO.	PART NO.
	08/03/04	J62731	13R1439
			DEVELOPMENT NO.
			Q/M
			26 / 83

13R1439

DESIGNER	Y.I	08/03/04	PART NO.	IBM
CHECKED	Y.Y	08/03/04	13R1439	
APPROVED	K.T	08/03/04	TITLE	ROME-3.5 AP13 (V070)
CLASS	K.T	08/03/04		ICH4-M (2/3)
THIS DOCUMENT IS THE PROPERTY OF IBM. ITS USE IS AUTHORIZED ONLY FOR RESPONDING TO A REQUEST FOR QUOTATION OR FOR THE PERFORMANCE OF WORK FOR IBM. ALL QUESTIONS MUST BE REFERRED TO THE IBM PURCHASING DEPARTMENT.				IBM CONFIDENTIAL

DATE	EC NO.	PART NO.	
REL 08/03/04	J62731	13R1439	
		DEVELOPMENT NO.	Q/M
			27 /83

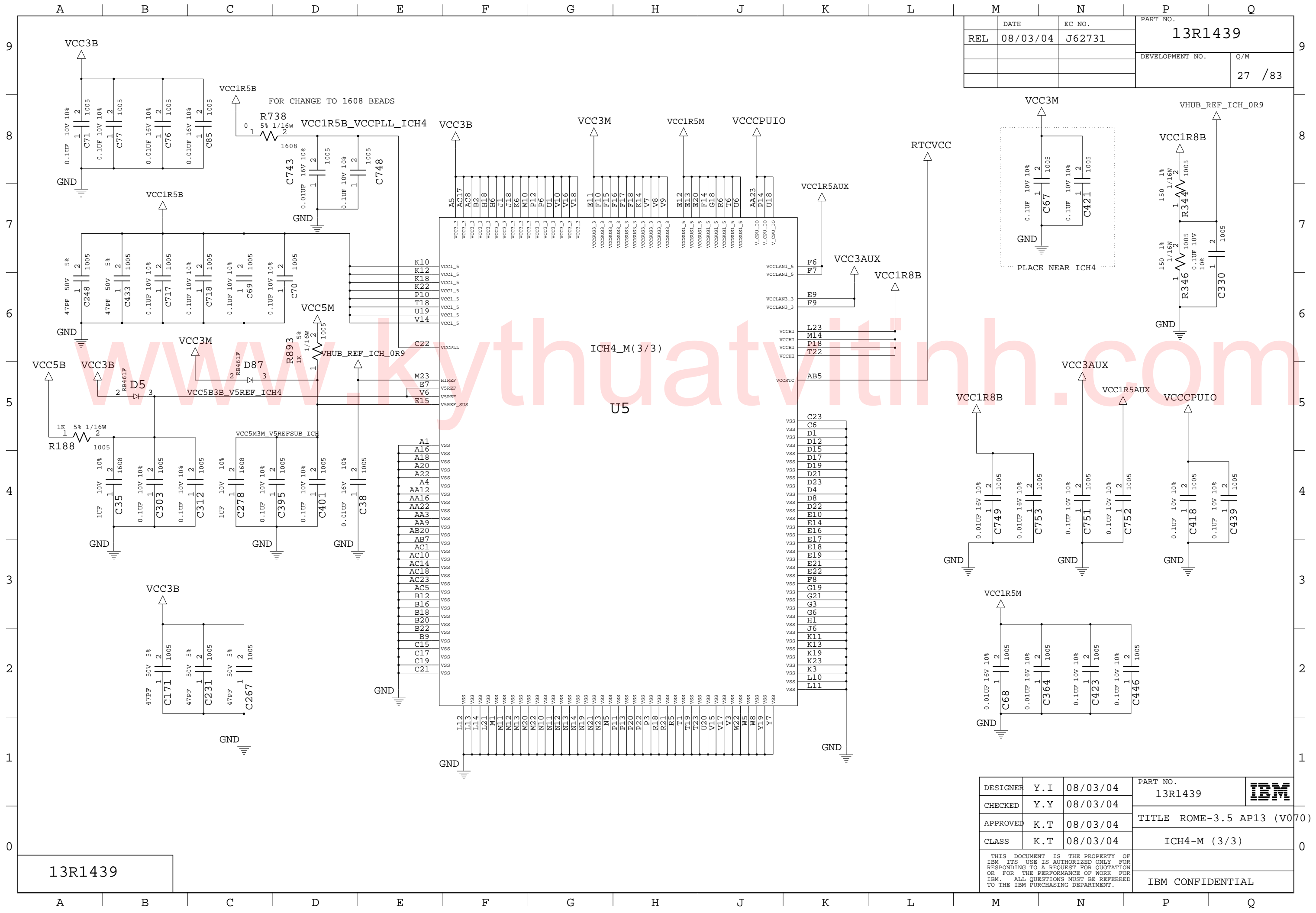

13R1439

DESIGNER	Y.I	08/03/04	PART NO.	13R1439	
CHECKED	Y.Y	08/03/04			
APPROVED	K.T	08/03/04	TITLE ROME-3.5 AP13 (V070)		
CLASS	K.T	08/03/04	ICH4-M (3/3)		
THIS DOCUMENT IS THE PROPERTY OF IBM. ITS USE IS AUTHORIZED ONLY FOR RESPONDING TO A REQUEST FOR QUOTATION OR FOR THE PERFORMANCE OF WORK FOR IBM. ALL QUESTIONS MUST BE REFERRED TO THE IBM PURCHASING DEPARTMENT.					IBM CONFIDENTIAL

	DATE	EC NO.	PART NO.	
REL	08/03/04	J62731	13R1439	
			DEVELOPMENT NO.	Q/M
				28 /83

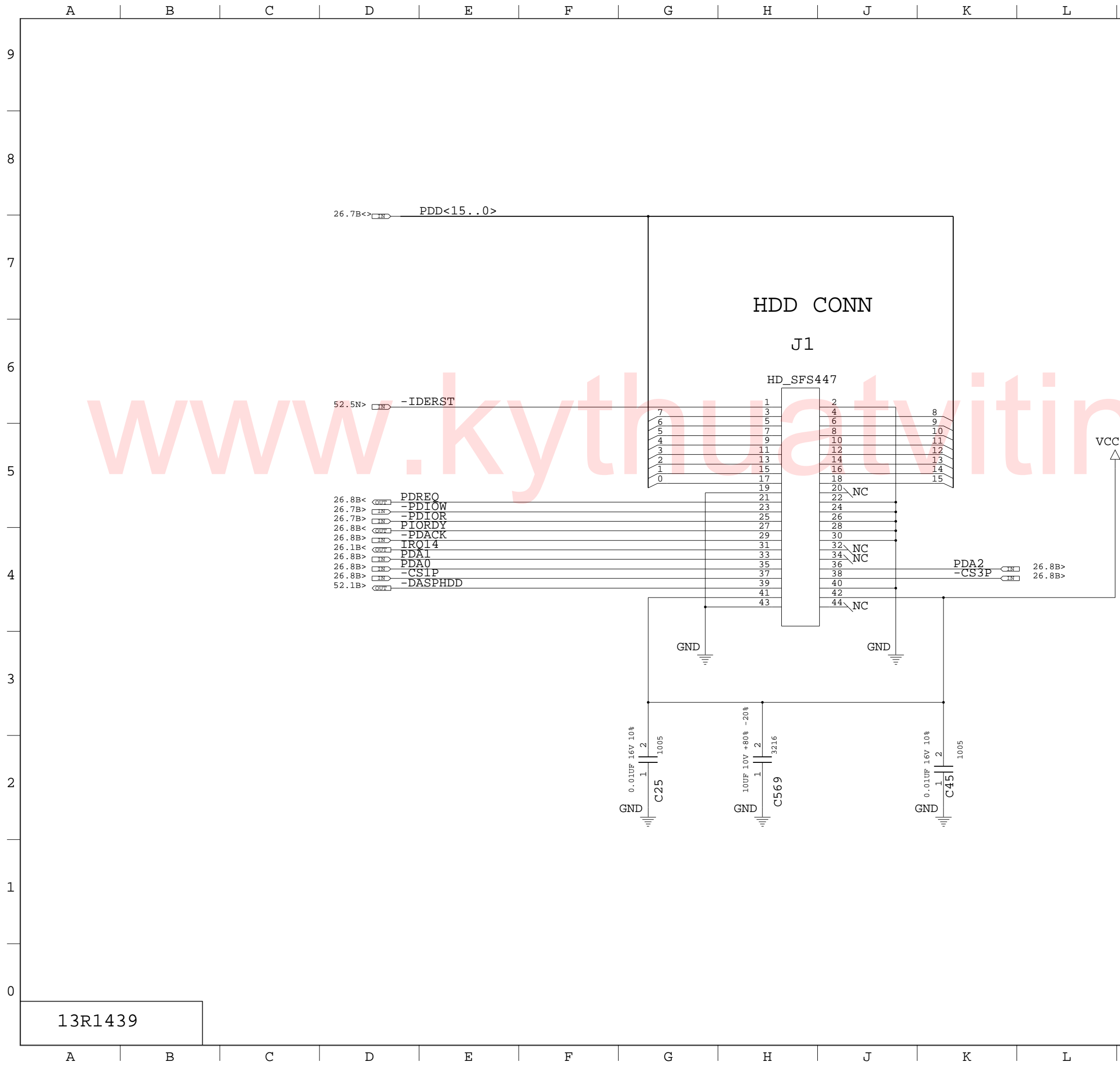

13R1439

DESIGNER	Y.I	08/03/04	PART NO.	13R1439	
CHECKED	Y.Y	08/03/04			
APPROVED	K.T	08/03/04	TITLE ROME-3.5 AP13 (V070)		
CLASS	K.T	08/03/04	HDD I/F CONNECTOR		
THIS DOCUMENT IS THE PROPERTY OF IBM. ITS USE IS AUTHORIZED ONLY FOR RESPONDING TO A REQUEST FOR QUOTATION OR FOR THE PERFORMANCE OF WORK FOR IBM. ALL QUESTIONS MUST BE REFERRED TO THE IBM PURCHASING DEPARTMENT.				IBM CONFIDENTIAL	

	DATE	EC NO.	PART NO.	
REL	08/03/04	J62731	13R1439	
			DEVELOPMENT NO.	Q/M
				29 / 83

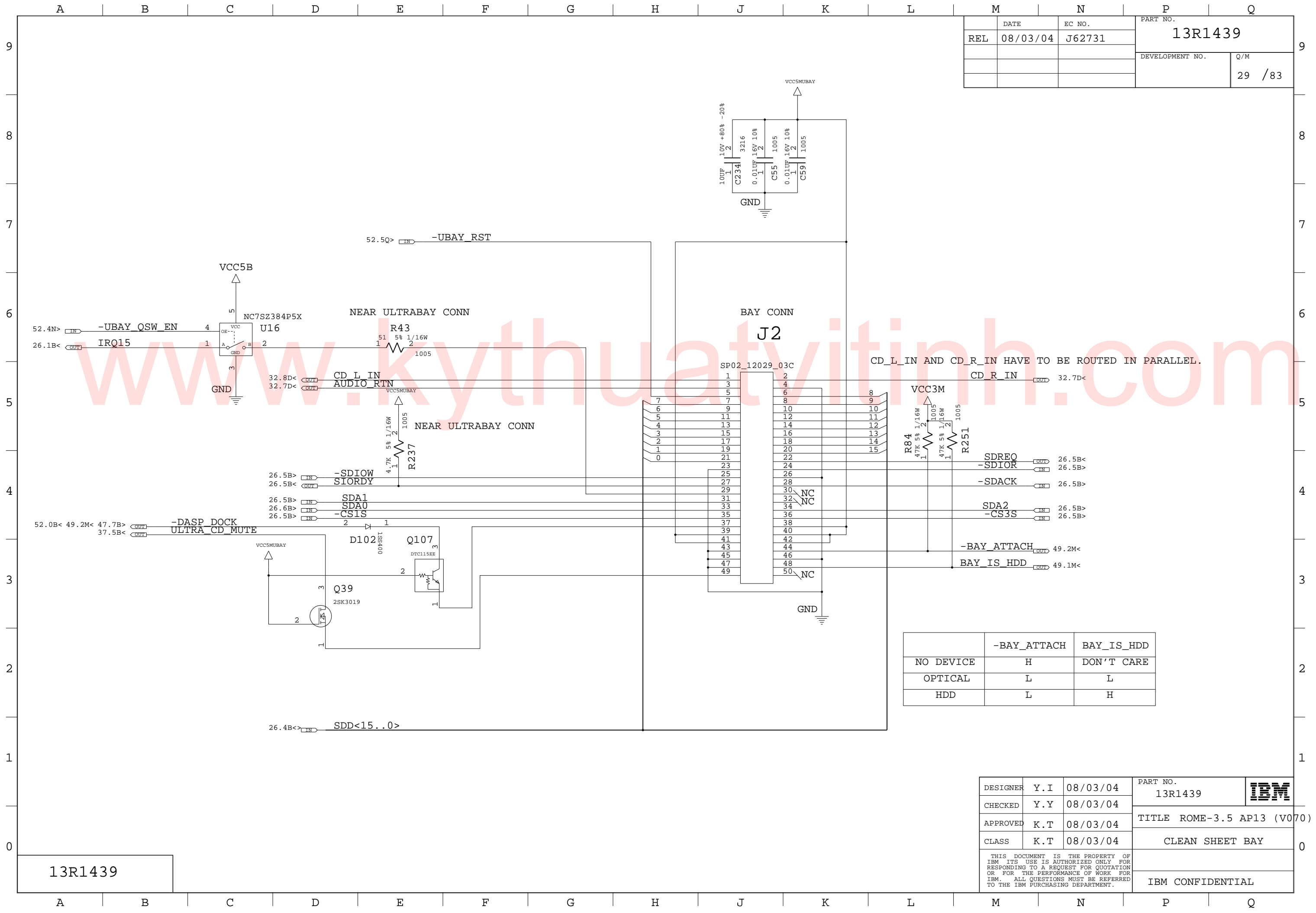

	-BAY_ATTACH	BAY_IS_HDD
NO DEVICE	H	DON'T CARE
OPTICAL	L	L
HDD	L	H

DESIGNER	Y.I	08/03/04	PART NO.	13R1439	
CHECKED	Y.Y	08/03/04			
APPROVED	K.T	08/03/04	TITLE ROME-3.5 AP13 (V070)		
CLASS	K.T	08/03/04	CLEAN SHEET BAY		
THIS DOCUMENT IS THE PROPERTY OF IBM. ITS USE IS AUTHORIZED ONLY FOR RESPONDING TO A REQUEST FOR QUOTATION OR FOR THE PERFORMANCE OF WORK FOR IBM. ALL QUESTIONS MUST BE REFERRED TO THE IBM PURCHASING DEPARTMENT.					IBM CONFIDENTIAL

13R1439

	DATE	EC NO.	PART NO.	
REL	08/03/04	J62731	13R1439	
			DEVELOPMENT NO.	Q/M
				30 /83

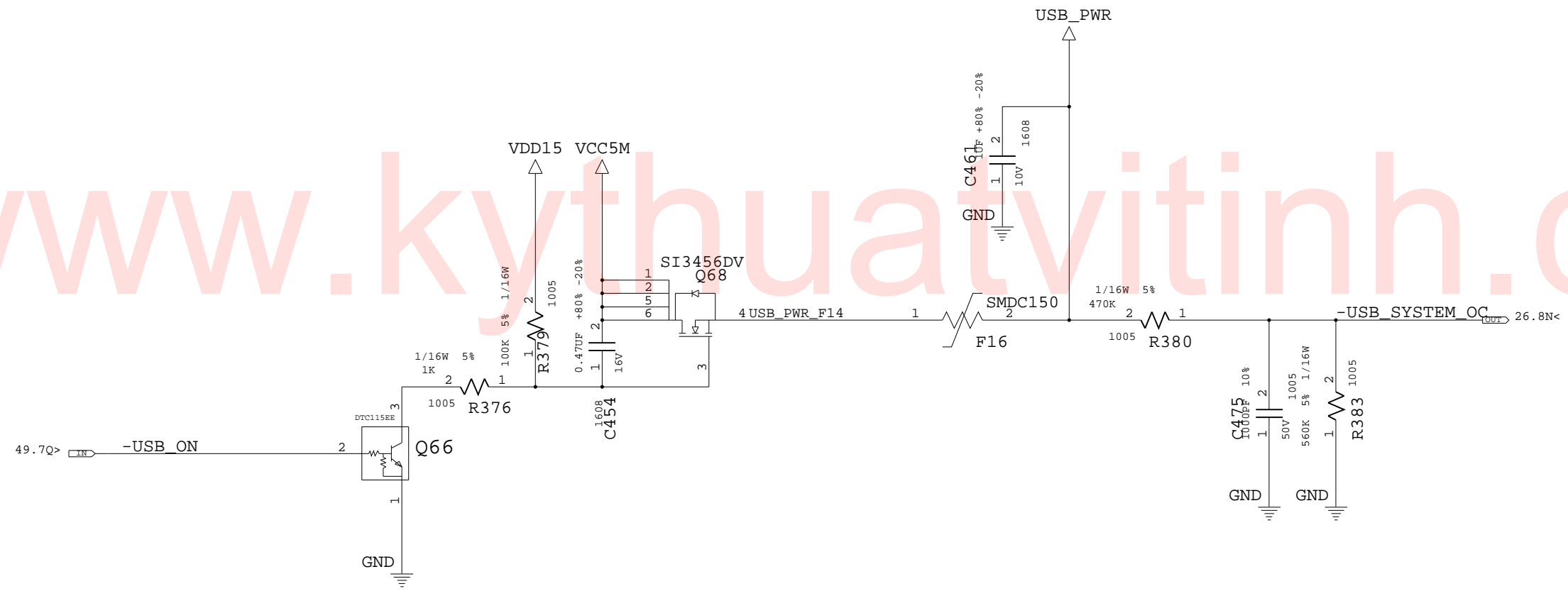

13R1439

DESIGNER	Y.I	08/03/04	PART NO.	13R1439	<b>IBM</b>
CHECKED	Y.Y	08/03/04			
APPROVED	K.T	08/03/04	TITLE ROME-3.5 AP13 (V070)		
CLASS	K.T	08/03/04	USB INTERFACE		
THIS DOCUMENT IS THE PROPERTY OF IBM. ITS USE IS AUTHORIZED ONLY FOR RESPONDING TO A REQUEST FOR QUOTATION OR FOR THE PERFORMANCE OF WORK FOR IBM. ALL QUESTIONS MUST BE REFERRED TO THE IBM PURCHASING DEPARTMENT.				IBM CONFIDENTIAL	

DATE	EC NO.	PART NO.	
REL 08/03/04	J62731	13R1439	
		DEVELOPMENT NO.	Q/M
			31 / 83

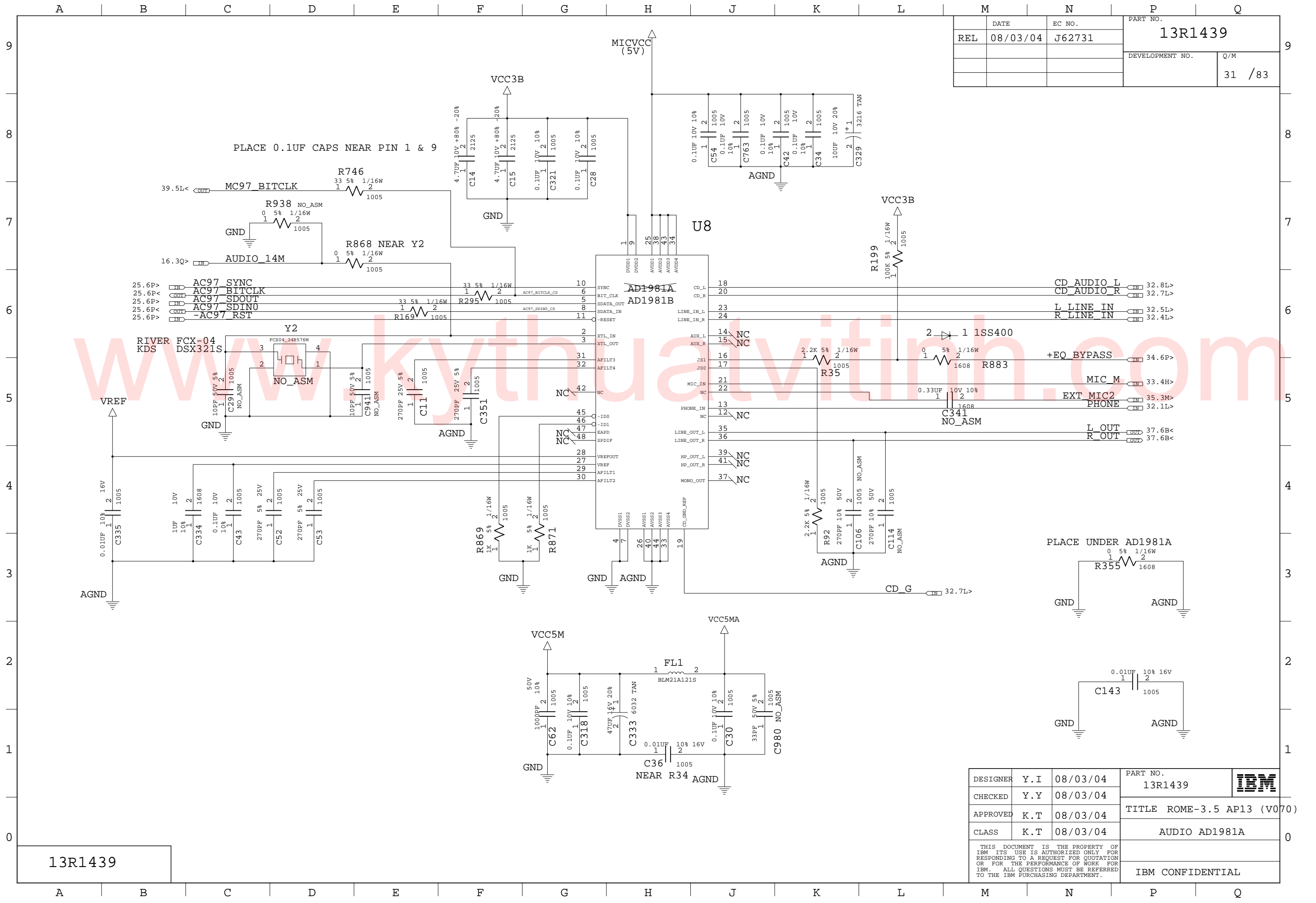

13R1439

DESIGNER	Y.I	08/03/04	PART NO.	13R1439	
CHECKED	Y.Y	08/03/04			
APPROVED	K.T	08/03/04	TITLE ROME-3.5 AP13 (V070)		
CLASS	K.T	08/03/04	AUDIO AD1981A		
THIS DOCUMENT IS THE PROPERTY OF IBM. ITS USE IS AUTHORIZED ONLY FOR RESPONDING TO A REQUEST FOR QUOTATION OR FOR THE PERFORMANCE OF WORK FOR IBM. ALL QUESTIONS MUST BE REFERRED TO THE IBM PURCHASING DEPARTMENT.					IBM CONFIDENTIAL

A B C D E F G H J K L M N P Q

	DATE	EC NO.	PART NO.	
REL	08/03/04	J62731	13R1439	
			DEVELOPMENT NO.	Q/M
				32 /83

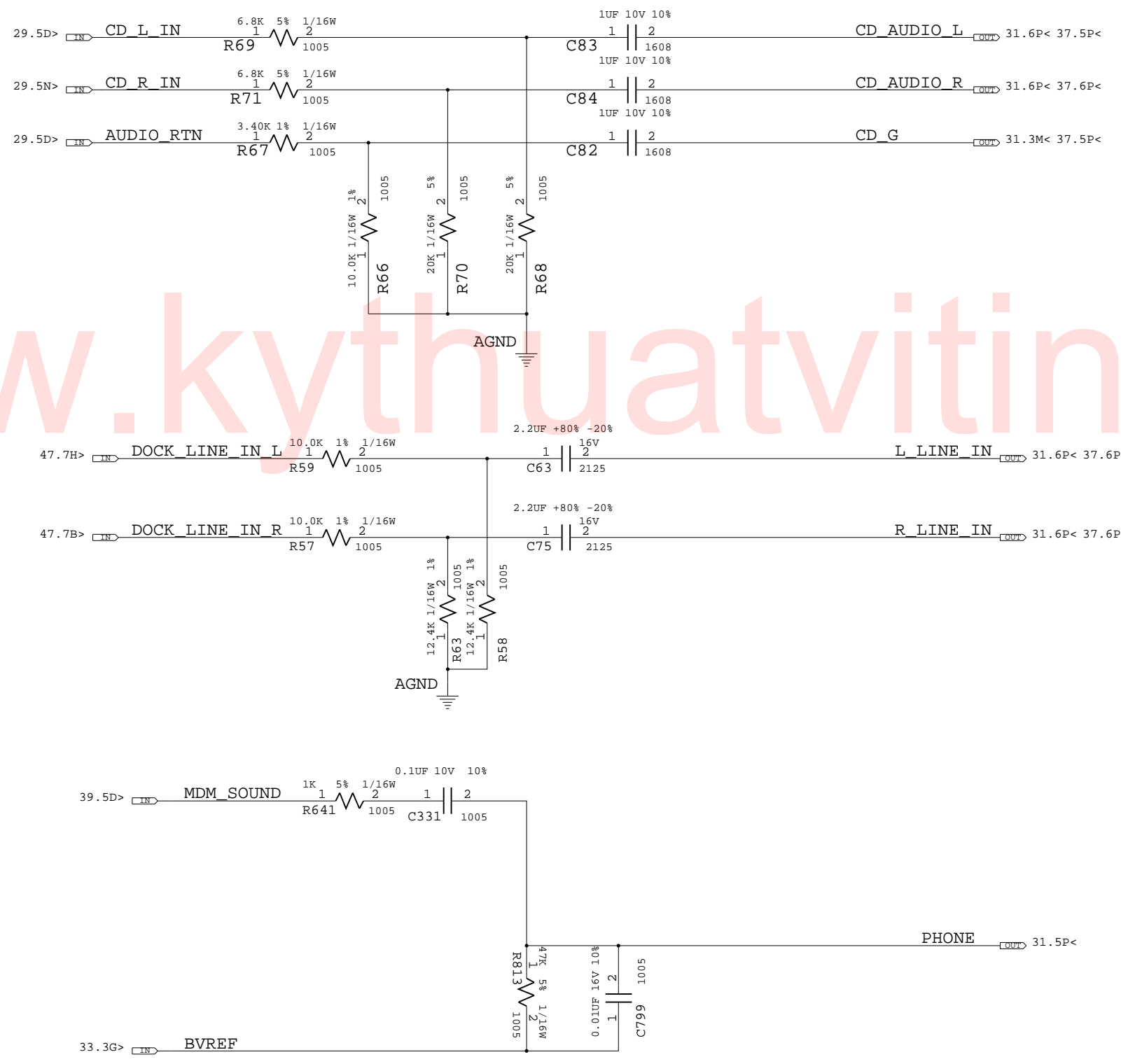

13R1439

DESIGNER	Y.I	08/03/04	PART NO.	13R1439	
CHECKED	Y.Y	08/03/04			
APPROVED	K.T	08/03/04	TITLE ROME-3.5 AP13 (V070)		
CLASS	K.T	08/03/04	AUDIO MISC		
THIS DOCUMENT IS THE PROPERTY OF IBM. ITS USE IS AUTHORIZED ONLY FOR RESPONDING TO A REQUEST FOR QUOTATION OR FOR THE PERFORMANCE OF WORK FOR IBM. ALL QUESTIONS MUST BE REFERRED TO THE IBM PURCHASING DEPARTMENT.					IBM CONFIDENTIAL

A B C D E F G H J K L M N P Q



DATE	EC NO.	PART NO.	
REL 08/03/04	J62731	13R1439	
		DEVELOPMENT NO.	Q/M
			33 /83

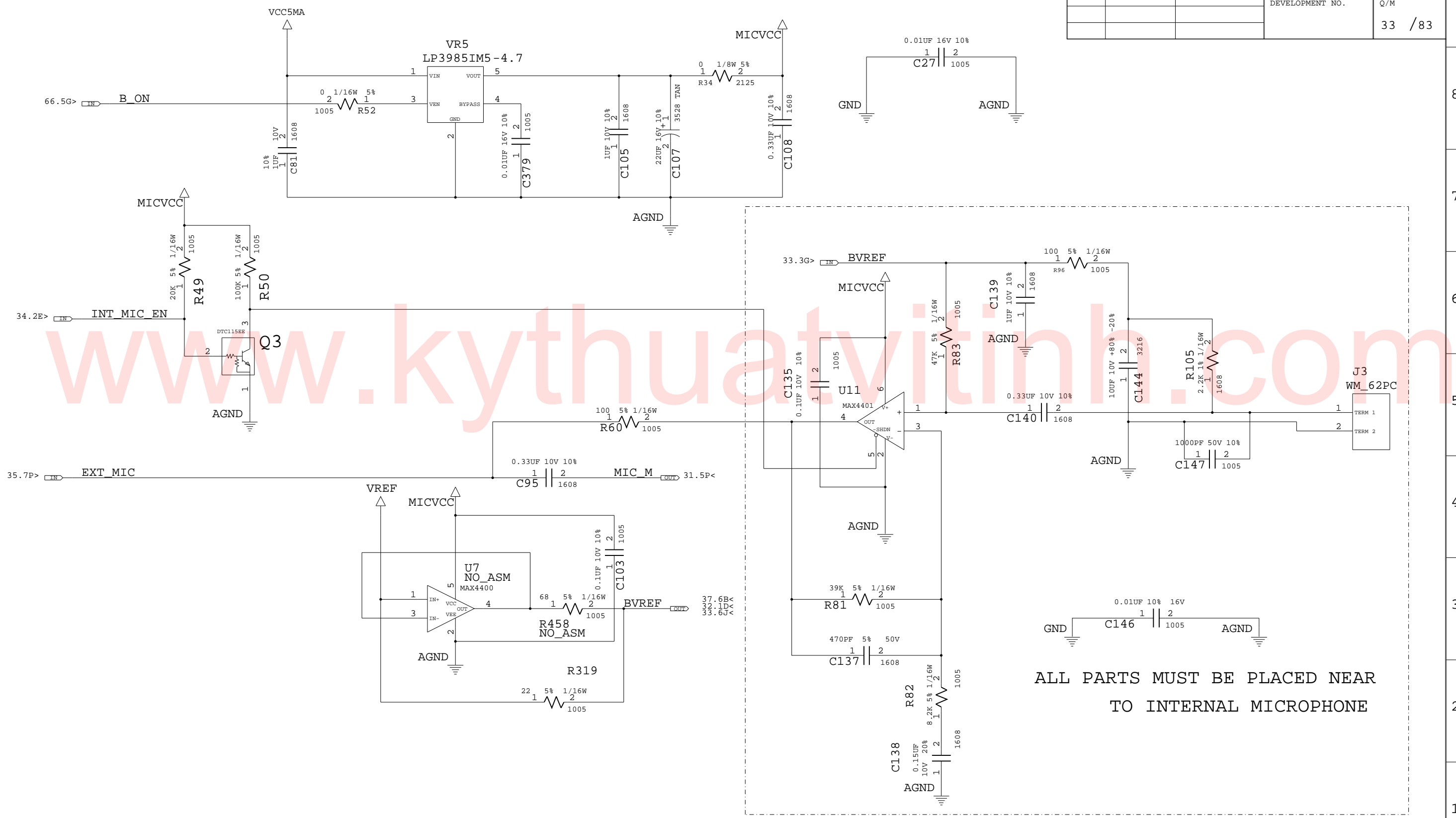

13R1439

DESIGNER	Y.I	08/03/04	PART NO.	13R1439	
CHECKED	Y.Y	08/03/04			
APPROVED	K.T	08/03/04	TITLE ROME-3.5 AP13 (V070)		
CLASS	K.T	08/03/04	AUDIO INT MIC		
THIS DOCUMENT IS THE PROPERTY OF IBM. ITS USE IS AUTHORIZED ONLY FOR RESPONDING TO A REQUEST FOR QUOTATION OR FOR THE PERFORMANCE OF WORK FOR IBM. ALL QUESTIONS MUST BE REFERRED TO THE IBM PURCHASING DEPARTMENT.				IBM CONFIDENTIAL	

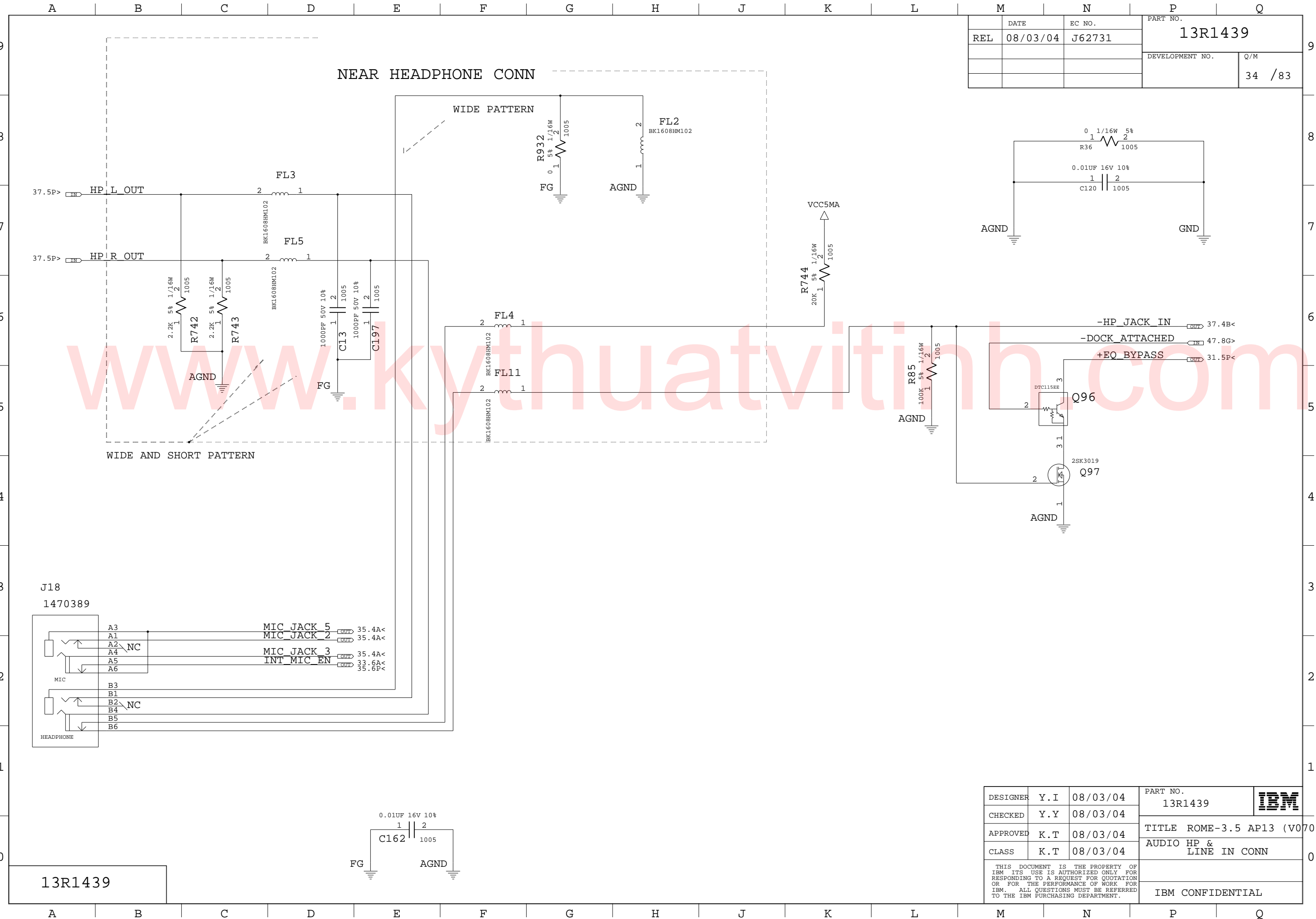

REL	DATE	EC NO.	PART NO.	
	08/03/04	J62731	13R1439	
			DEVELOPMENT NO.	Q/M
				34 /83

DESIGNER	Y.I	08/03/04	PART NO.	13R1439	
CHECKED	Y.Y	08/03/04			
APPROVED	K.T	08/03/04	TITLE ROME-3.5 AP13 (V070)		
CLASS	K.T	08/03/04	AUDIO HP & LINE IN CONN		
THIS DOCUMENT IS THE PROPERTY OF IBM. ITS USE IS AUTHORIZED ONLY FOR RESPONDING TO A REQUEST FOR QUOTATION OR FOR THE PERFORMANCE OF WORK FOR IBM. ALL QUESTIONS MUST BE REFERRED TO THE IBM PURCHASING DEPARTMENT.				IBM CONFIDENTIAL	

13R1439

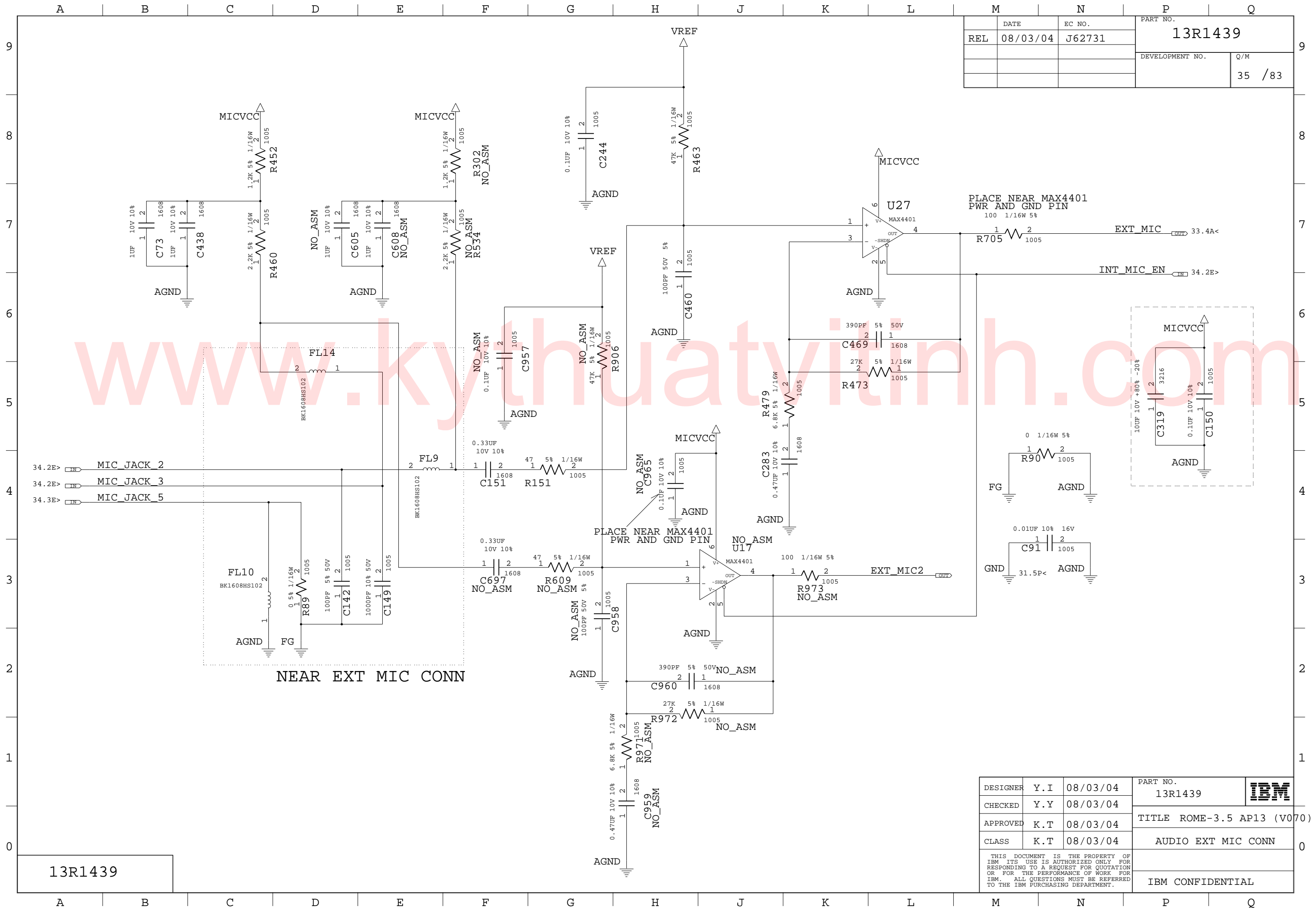

REL	DATE	EC NO.	PART NO.	
	08/03/04	J62731	13R1439	
			DEVELOPMENT NO.	Q/M
				35 /83

PLACE NEAR MAX4401  
PWR AND GND PIN  
100 1/16W 5%

0 1/16W 5%

0.01UF 10% 16V

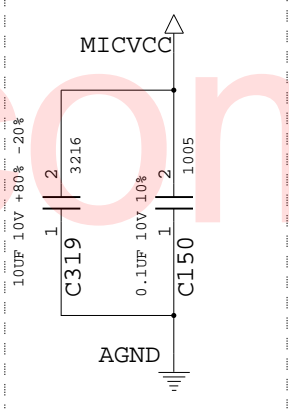

DESIGNER	Y.I	08/03/04	PART NO.	13R1439	
CHECKED	Y.Y	08/03/04			
APPROVED	K.T	08/03/04	TITLE ROME-3.5 AP13 (V070)		
CLASS	K.T	08/03/04	AUDIO EXT MIC CONN		
THIS DOCUMENT IS THE PROPERTY OF IBM. ITS USE IS AUTHORIZED ONLY FOR RESPONDING TO A REQUEST FOR QUOTATION OR FOR THE PERFORMANCE OF WORK FOR IBM. ALL QUESTIONS MUST BE REFERRED TO THE IBM PURCHASING DEPARTMENT.				IBM CONFIDENTIAL	

13R1439

A B C D E F G H J K L M N P Q

REL	DATE 08/03/04	EC NO. J62731	PART NO. 13R1439	
			DEVELOPMENT NO.	Q/M 36 /83

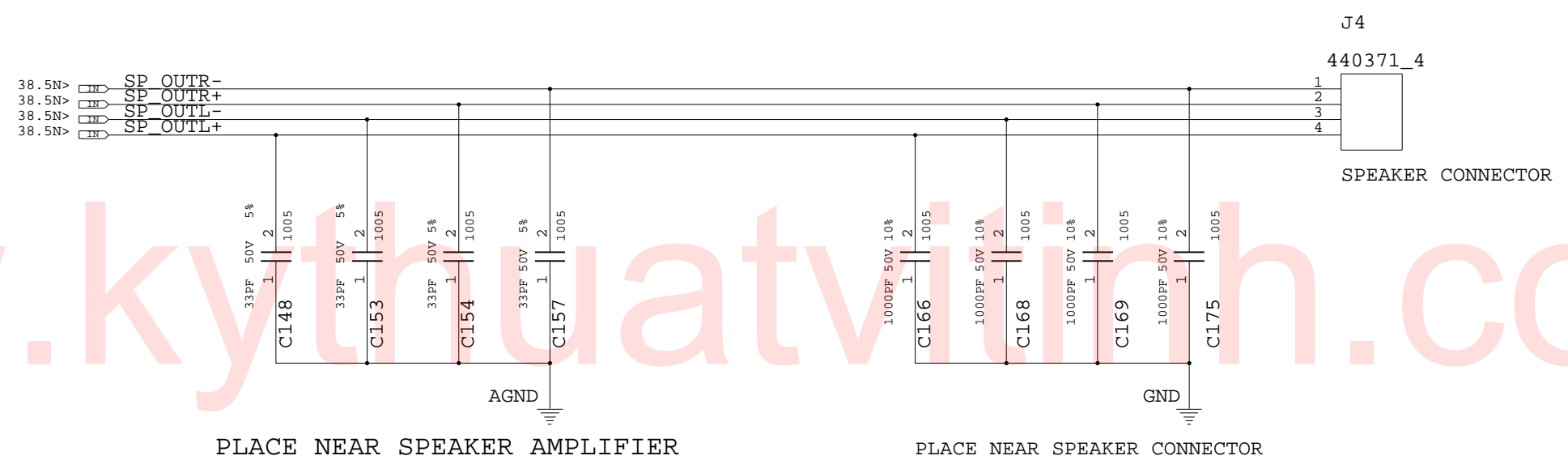

PLACE NEAR SPEAKER AMPLIFIER

PLACE NEAR SPEAKER CONNECTOR

www.kyathuathvith.com

13R1439

DESIGNER	Y.I	08/03/04	PART NO. 13R1439	<b>IBM</b>
CHECKED	Y.Y	08/03/04	TITLE ROME-3.5 AP13 (V070)	
APPROVED	K.T	08/03/04	AUDIO SPEAKER	
CLASS	K.T	08/03/04	IBM CONFIDENTIAL	

THIS DOCUMENT IS THE PROPERTY OF IBM. ITS USE IS AUTHORIZED ONLY FOR RESPONDING TO A REQUEST FOR QUOTATION OR FOR THE PERFORMANCE OF WORK FOR IBM. ALL QUESTIONS MUST BE REFERRED TO THE IBM PURCHASING DEPARTMENT.

A B C D E F G H J K L M N P Q

	DATE	EC NO.	PART NO.	
REL	08/03/04	J62731	13R1439	
			DEVELOPMENT NO.	Q/M
				37 / 83

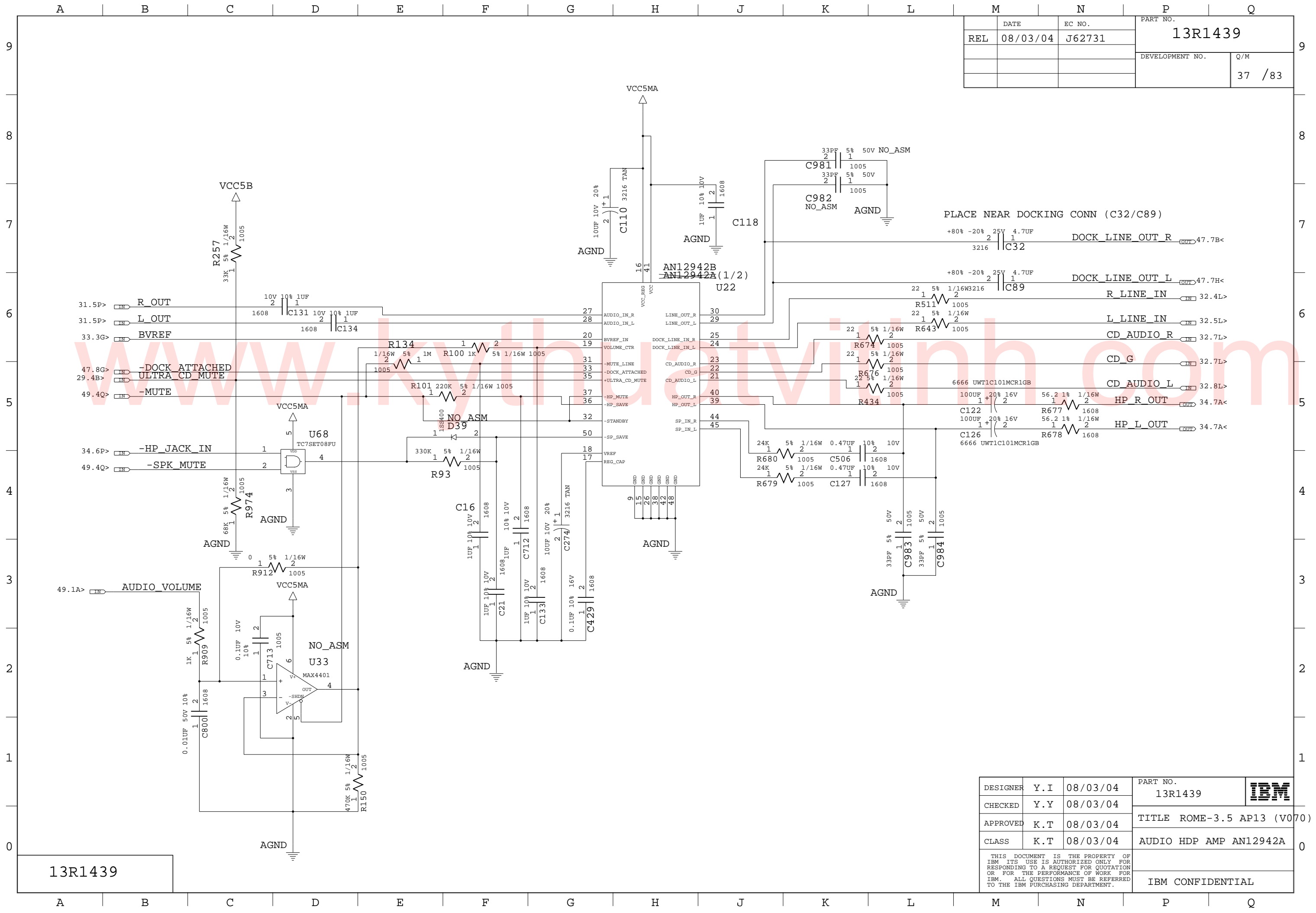

13R1439

DESIGNER	Y.I	08/03/04	PART NO.	13R1439	
CHECKED	Y.Y	08/03/04			
APPROVED	K.T	08/03/04	TITLE ROME-3.5 AP13 (V070)		
CLASS	K.T	08/03/04	AUDIO HDP AMP AN12942A		
THIS DOCUMENT IS THE PROPERTY OF IBM. ITS USE IS AUTHORIZED ONLY FOR RESPONDING TO A REQUEST FOR QUOTATION OR FOR THE PERFORMANCE OF WORK FOR IBM. ALL QUESTIONS MUST BE REFERRED TO THE IBM PURCHASING DEPARTMENT.				IBM CONFIDENTIAL	

	DATE	EC NO.	PART NO.	
REL	08/03/04	J62731	13R1439	
			DEVELOPMENT NO.	Q/M
				38 / 83

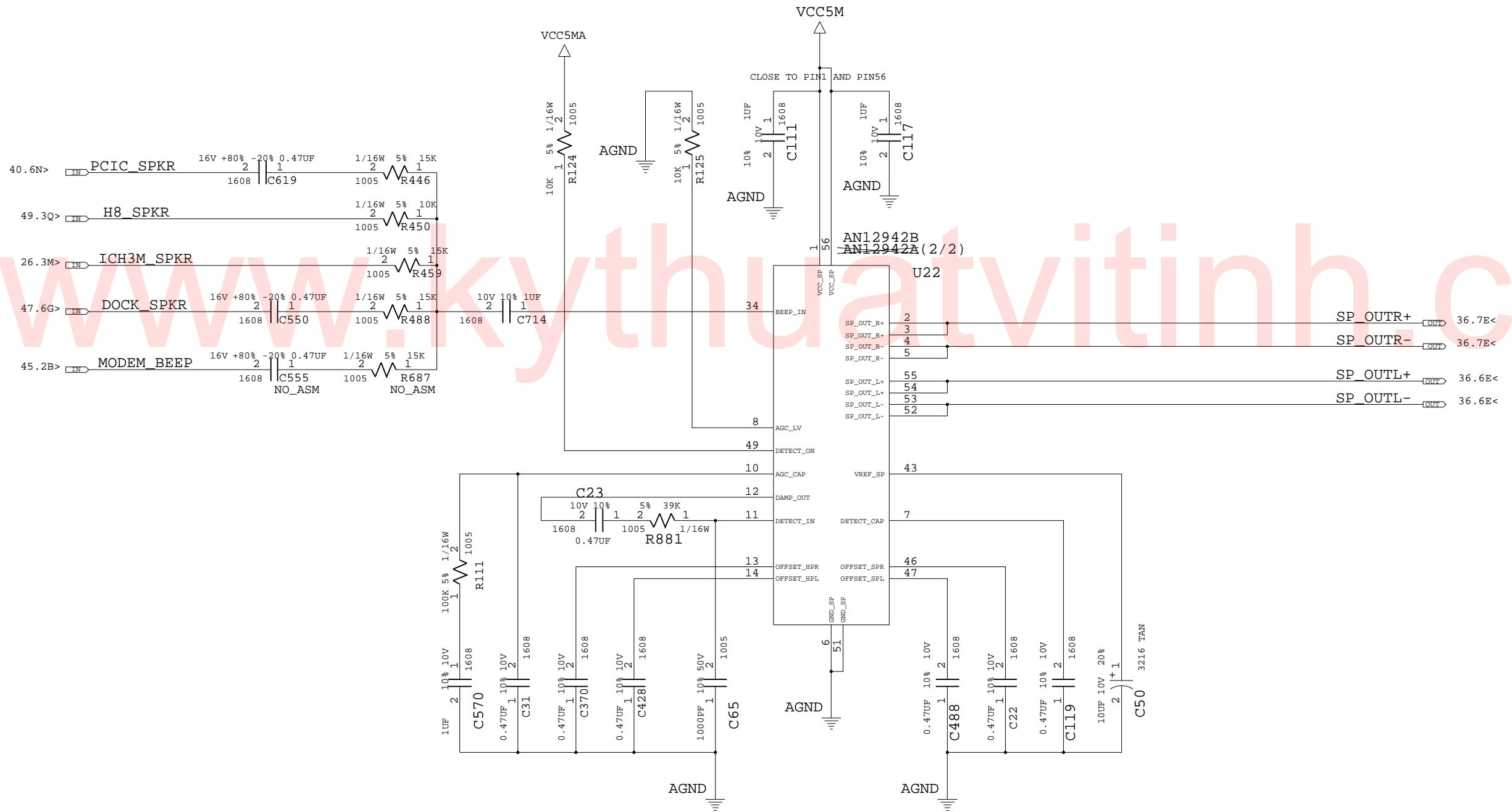

13R1439

DESIGNER	Y.I	08/03/04	PART NO.	13R1439	
CHECKED	Y.Y	08/03/04			
APPROVED	K.T	08/03/04	TITLE ROME-3.5 AP13 (V070)		
CLASS	K.T	08/03/04	AUDIO HDP AMP AN12942A		
THIS DOCUMENT IS THE PROPERTY OF IBM. ITS USE IS AUTHORIZED ONLY FOR RESPONDING TO A REQUEST FOR QUOTATION OR FOR THE PERFORMANCE OF WORK FOR IBM. ALL QUESTIONS MUST BE REFERRED TO THE IBM PURCHASING DEPARTMENT.				IBM CONFIDENTIAL	

A B C D E F G H J K L M N P Q

	DATE	EC NO.	PART NO.	
REL	08/03/04	J62731	13R1439	
			DEVELOPMENT NO.	Q/M
				39 /83

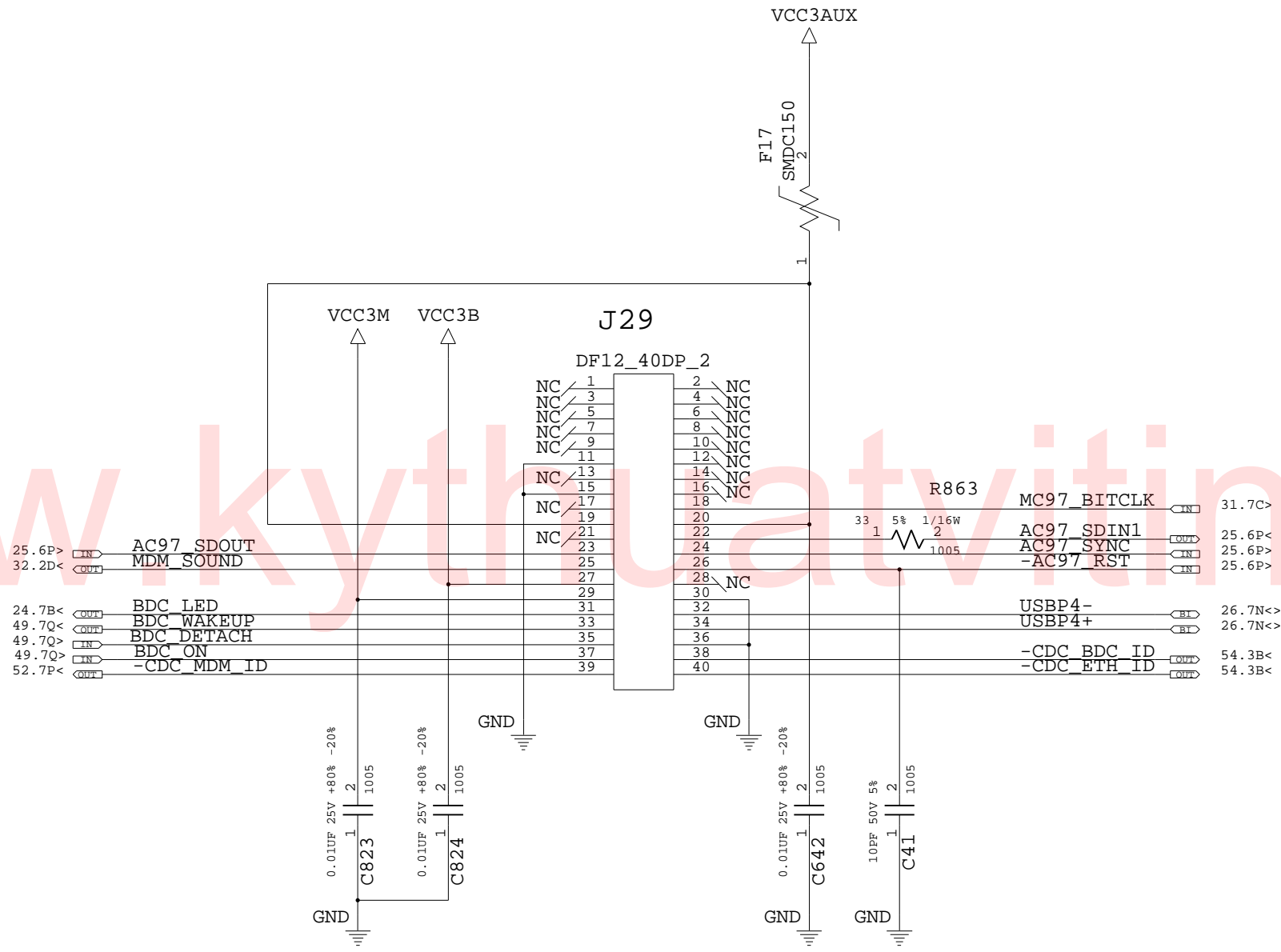

13R1439

DESIGNER	Y.I	08/03/04	PART NO.	13R1439	
CHECKED	Y.Y	08/03/04			
APPROVED	K.T	08/03/04	TITLE ROME-3.5 AP13 (V070)		
CLASS	K.T	08/03/04	CDC CONNECTOR		
THIS DOCUMENT IS THE PROPERTY OF IBM. ITS USE IS AUTHORIZED ONLY FOR RESPONDING TO A REQUEST FOR QUOTATION OR FOR THE PERFORMANCE OF WORK FOR IBM. ALL QUESTIONS MUST BE REFERRED TO THE IBM PURCHASING DEPARTMENT.				IBM CONFIDENTIAL	

A B C D E F G H J K L M N P Q





	DATE	EC NO.	PART NO.	
REL	08/03/04	J62731	13R1439	
			DEVELOPMENT NO.	Q/M
			41	/83

U20

PCI4520GHK (2/2)

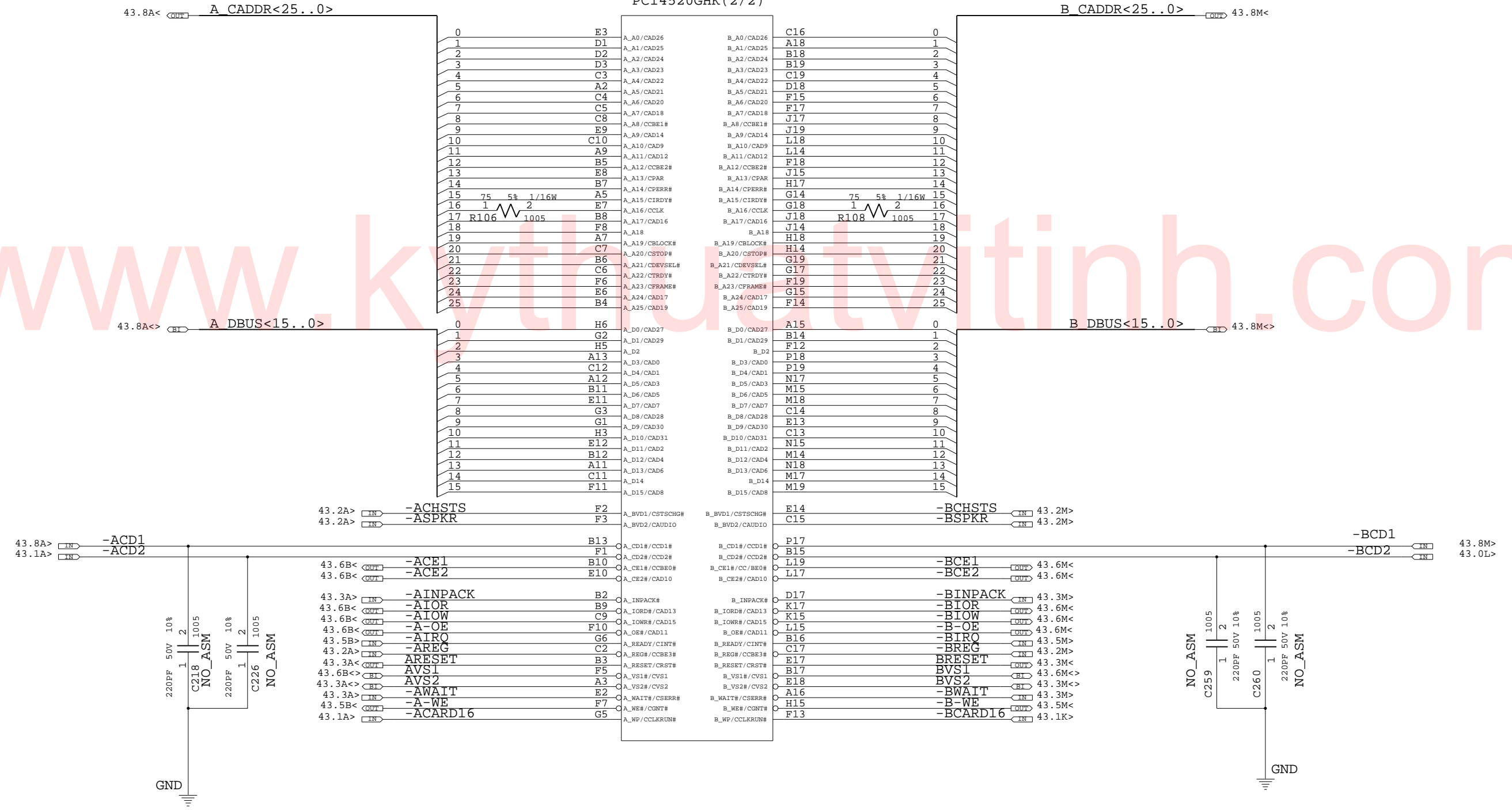

	CARDBUS	
	1 SLOT	2 SLOTS
R106	ASM	ASM
C218	NOASM	NOASM
C226	NOASM	NOASM
R108	NOASM	ASM
C259	NOASM	NOASM
C260	NOASM	NOASM

DESIGNER	Y.I	08/03/04	PART NO.	13R1439	
CHECKED	Y.Y	08/03/04			
APPROVED	K.T	08/03/04	TITLE ROME-3.5 AP13 (V070)		
CLASS	K.T	08/03/04	CARD BUS PCI4520 (2/2)		

THIS DOCUMENT IS THE PROPERTY OF IBM. ITS USE IS AUTHORIZED ONLY FOR RESPONDING TO A REQUEST FOR QUOTATION OR FOR THE PERFORMANCE OF WORK FOR IBM. ALL QUESTIONS MUST BE REFERRED TO THE IBM PURCHASING DEPARTMENT.

IBM CONFIDENTIAL

13R1439

	DATE	EC NO.	PART NO.	
REL	08/03/04	J62731	13R1439	
			DEVELOPMENT NO.	Q/M
				42 / 83

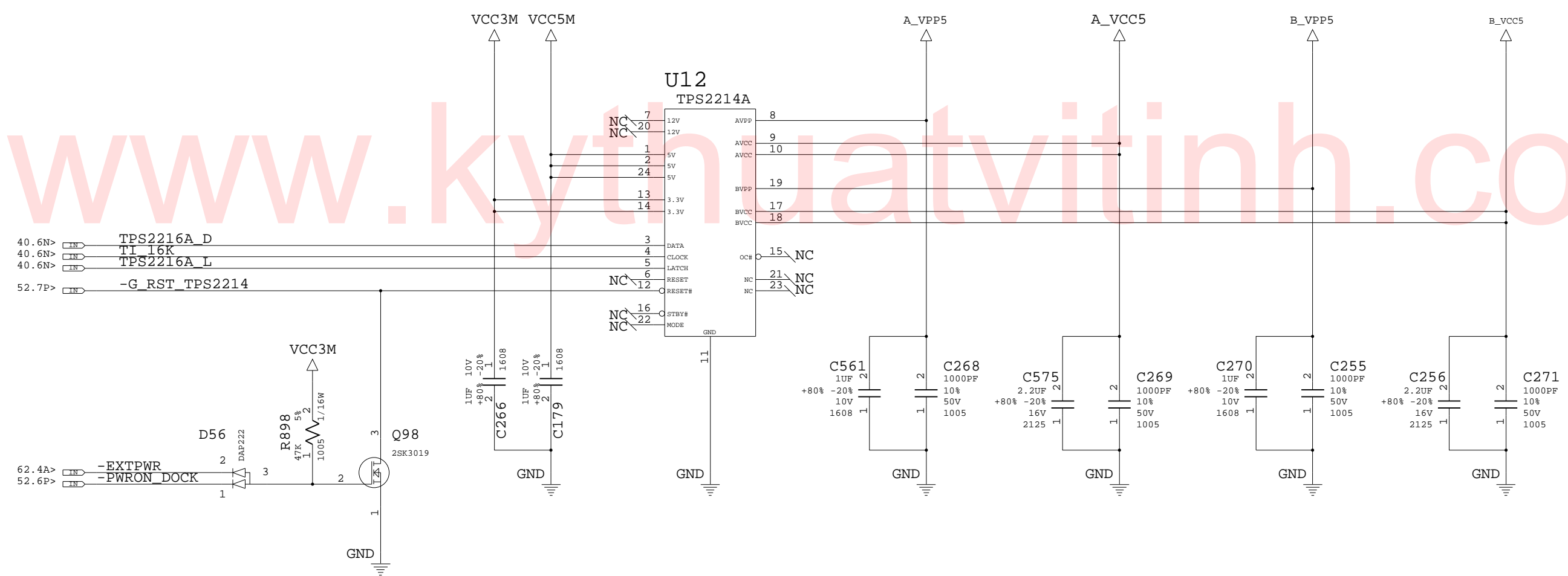

CARDBUS		
	1 SLOT	2 SLOTS
C561	ASM	ASM
C268	ASM	ASM
C575	ASM	ASM
C269	ASM	ASM
C270	NOASM	ASM
C255	NOASM	ASM
C256	NOASM	ASM
C271	NOASM	ASM

13R1439

DESIGNER	Y.I	08/03/04	PART NO.	13R1439	
CHECKED	Y.Y	08/03/04			
APPROVED	K.T	08/03/04	TITLE ROME-3.5 AP13 (V070)		
CLASS	K.T	08/03/04	CARD BUS POWER CONTROL		
THIS DOCUMENT IS THE PROPERTY OF IBM. ITS USE IS AUTHORIZED ONLY FOR RESPONDING TO A REQUEST FOR QUOTATION OR FOR THE PERFORMANCE OF WORK FOR IBM. ALL QUESTIONS MUST BE REFERRED TO THE IBM PURCHASING DEPARTMENT.				IBM CONFIDENTIAL	

DATE	EC NO.	PART NO.	
REL 08/03/04	J62731	13R1439	
		DEVELOPMENT NO.	Q/M
			43 / 83

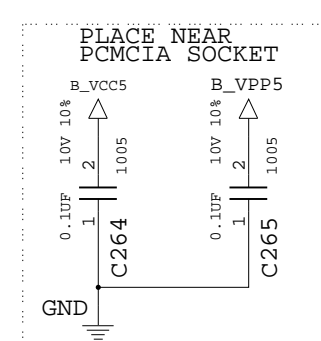
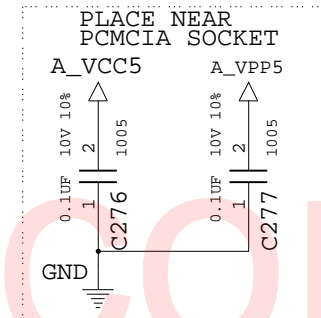
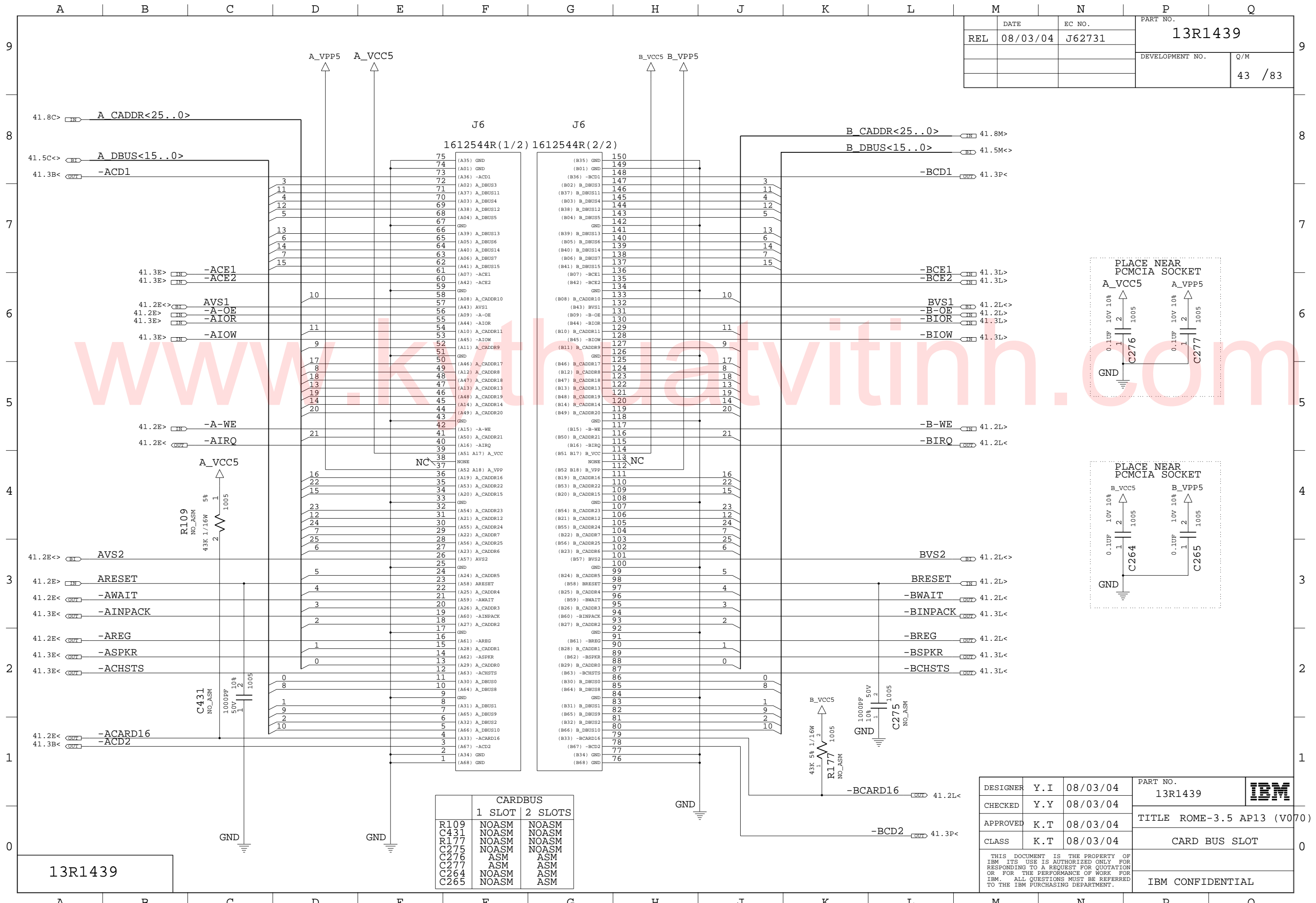

CARDBUS		
	1 SLOT	2 SLOTS
R109	NOASM	NOASM
C431	NOASM	NOASM
R177	NOASM	NOASM
C275	NOASM	NOASM
C276	ASM	ASM
C277	ASM	ASM
C264	NOASM	ASM
C265	NOASM	ASM

DESIGNER	Y.I	08/03/04	PART NO.	13R1439	
CHECKED	Y.Y	08/03/04			
APPROVED	K.T	08/03/04	TITLE ROME-3.5 AP13 (V070)		
CLASS	K.T	08/03/04	CARD BUS SLOT		
THIS DOCUMENT IS THE PROPERTY OF IBM. ITS USE IS AUTHORIZED ONLY FOR RESPONDING TO A REQUEST FOR QUOTATION OR FOR THE PERFORMANCE OF WORK FOR IBM. ALL QUESTIONS MUST BE REFERRED TO THE IBM PURCHASING DEPARTMENT.					IBM CONFIDENTIAL

13R1439

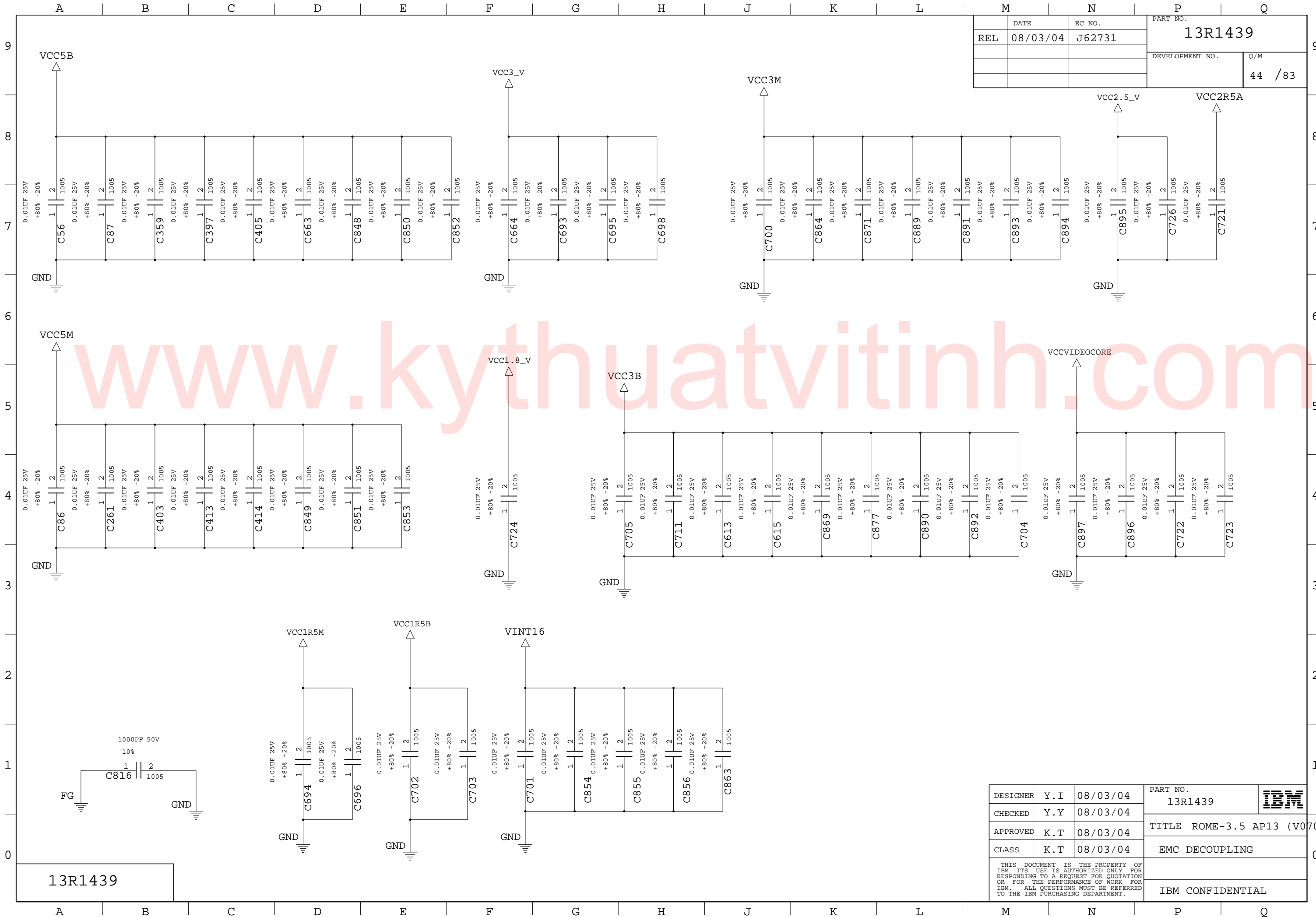

REL	DATE	EC NO.	PART NO.	
	08/03/04	J62731	13R1439	
			DEVELOPMENT NO.	Q/M
				44 / 83

DESIGNER	Y.I	08/03/04	PART NO.	13R1439	
CHECKED	Y.Y	08/03/04	TITLE		
APPROVED	K.T	08/03/04	EMC DECOUPLING		
CLASS	K.T	08/03/04	IBM CONFIDENTIAL		

THIS DOCUMENT IS THE PROPERTY OF IBM. ITS USE IS AUTHORIZED ONLY FOR RESPONDING TO A REQUEST FOR QUOTATION OR FOR THE PERFORMANCE OF WORK FOR IBM. ALL QUESTIONS MUST BE REFERRED TO THE IBM PURCHASING DEPARTMENT.

13R1439

A B C D E F G H J K L M N P Q

REL	DATE	EC NO.	PART NO.	
	08/03/04	J62731	13R1439	
			DEVELOPMENT NO.	Q/M
				45 / 83

# MINI PCI

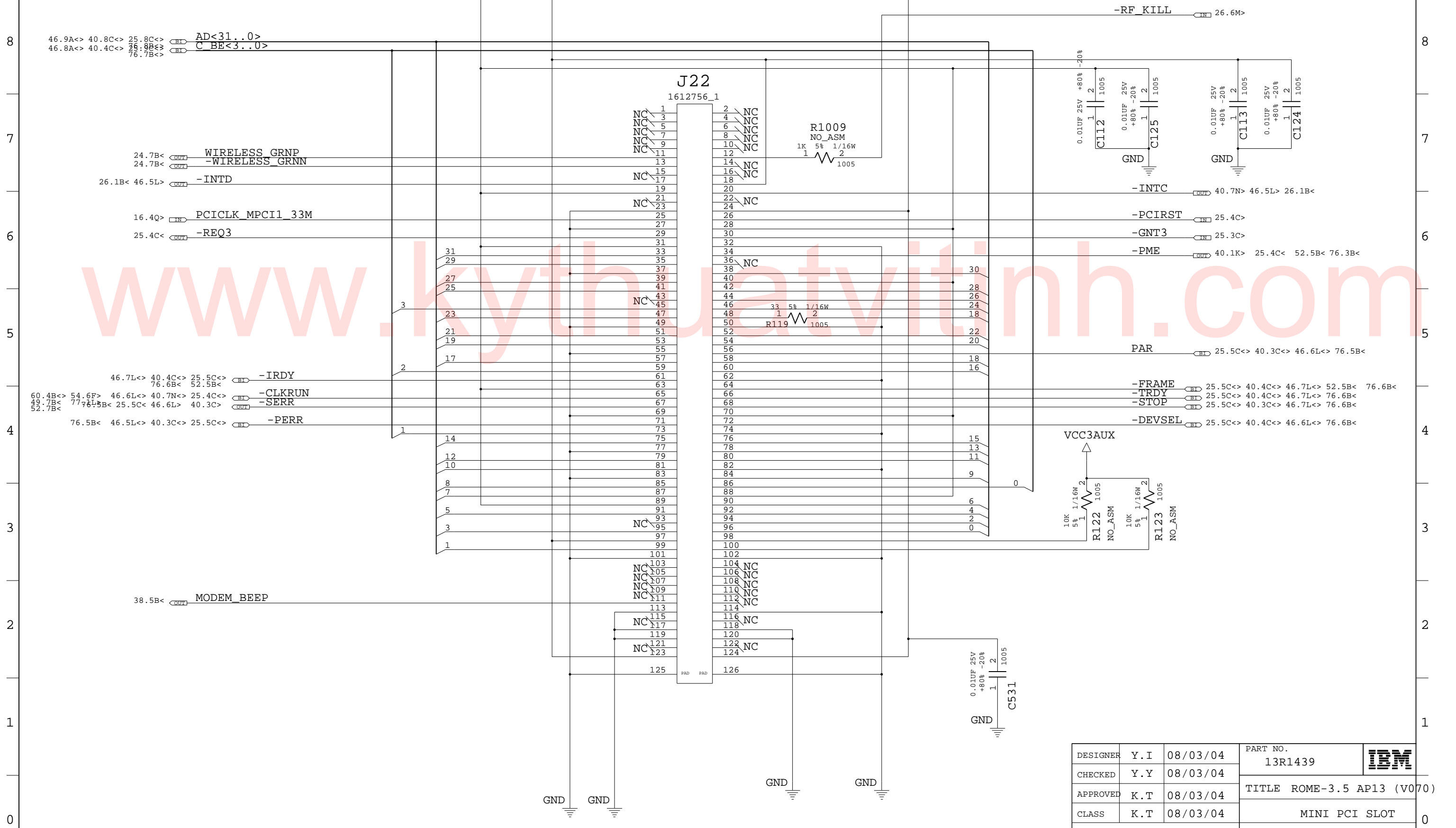

13R1439

DESIGNER	Y.I	08/03/04	PART NO.	13R1439	
CHECKED	Y.Y	08/03/04			
APPROVED	K.T	08/03/04	TITLE ROME-3.5 AP13 (V070)		
CLASS	K.T	08/03/04	MINI PCI SLOT		
THIS DOCUMENT IS THE PROPERTY OF IBM. ITS USE IS AUTHORIZED ONLY FOR RESPONDING TO A REQUEST FOR QUOTATION OR FOR THE PERFORMANCE OF WORK FOR IBM. ALL QUESTIONS MUST BE REFERRED TO THE IBM PURCHASING DEPARTMENT.					IBM CONFIDENTIAL

A B C D E F G H J K L M N P Q

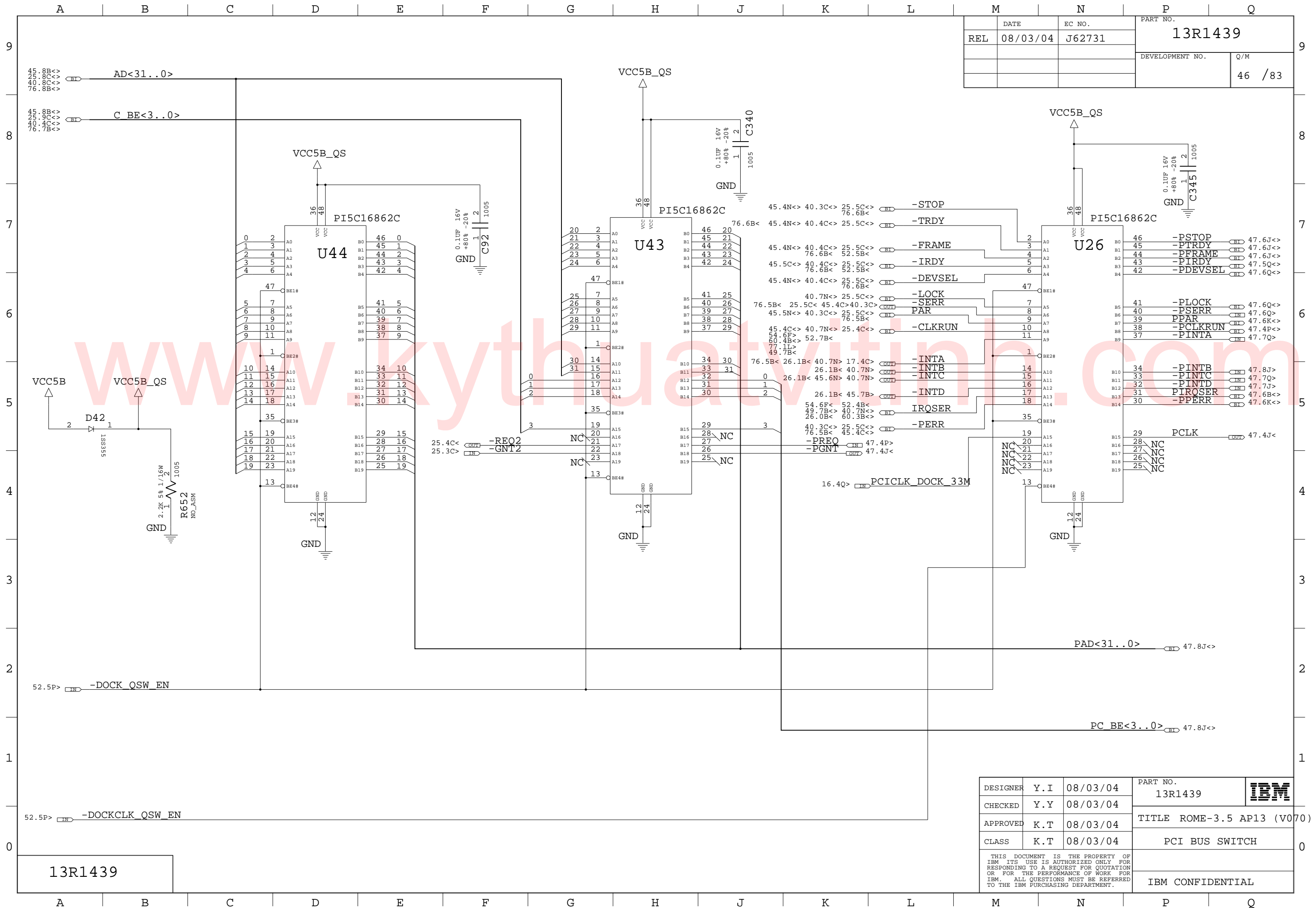

REL	DATE	EC NO.	PART NO.	
	08/03/04	J62731	13R1439	
			DEVELOPMENT NO.	Q/M
				46 / 83

DESIGNER	Y.I	08/03/04	PART NO.	13R1439	
CHECKED	Y.Y	08/03/04			
APPROVED	K.T	08/03/04	TITLE ROME-3.5 AP13 (V070)		
CLASS	K.T	08/03/04	PCI BUS SWITCH		
THIS DOCUMENT IS THE PROPERTY OF IBM. ITS USE IS AUTHORIZED ONLY FOR RESPONDING TO A REQUEST FOR QUOTATION OR FOR THE PERFORMANCE OF WORK FOR IBM. ALL QUESTIONS MUST BE REFERRED TO THE IBM PURCHASING DEPARTMENT.				IBM CONFIDENTIAL	

13R1439

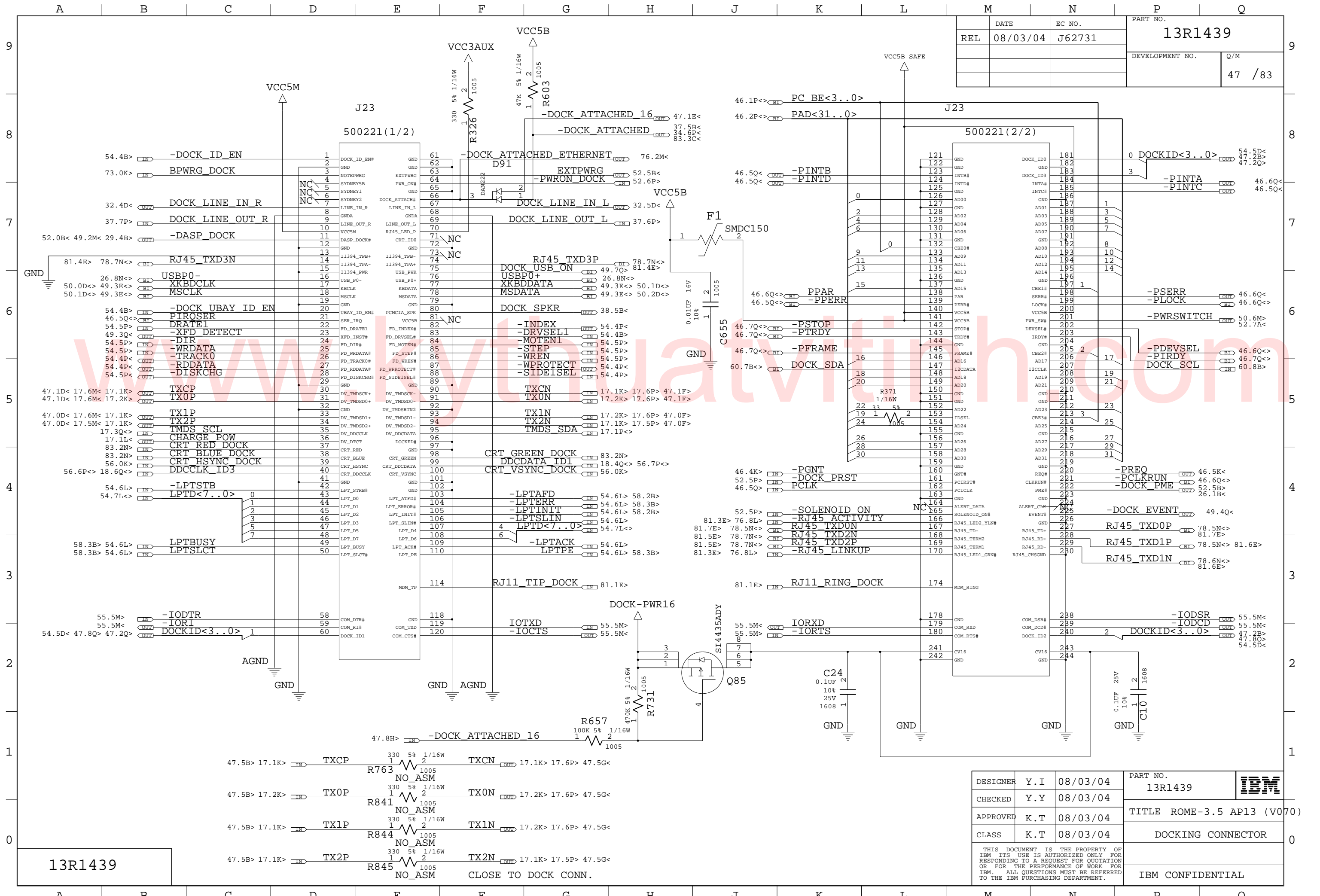

DATE	EC NO.	PART NO.
REL 08/03/04	J62731	13R1439
DEVELOPMENT NO.		Q/M
		47 / 83

DESIGNER	Y.I	08/03/04	PART NO.	13R1439	
CHECKED	Y.Y	08/03/04	TITLE		
APPROVED	K.T	08/03/04	DOCKING CONNECTOR		
CLASS	K.T	08/03/04	IBM CONFIDENTIAL		

THIS DOCUMENT IS THE PROPERTY OF IBM. ITS USE IS AUTHORIZED ONLY FOR RESPONDING TO A REQUEST FOR QUOTATION OR FOR THE PERFORMANCE OF WORK FOR IBM. ALL QUESTIONS MUST BE REFERRED TO THE IBM PURCHASING DEPARTMENT.

13R1439

CLOSE TO DOCK CONN.

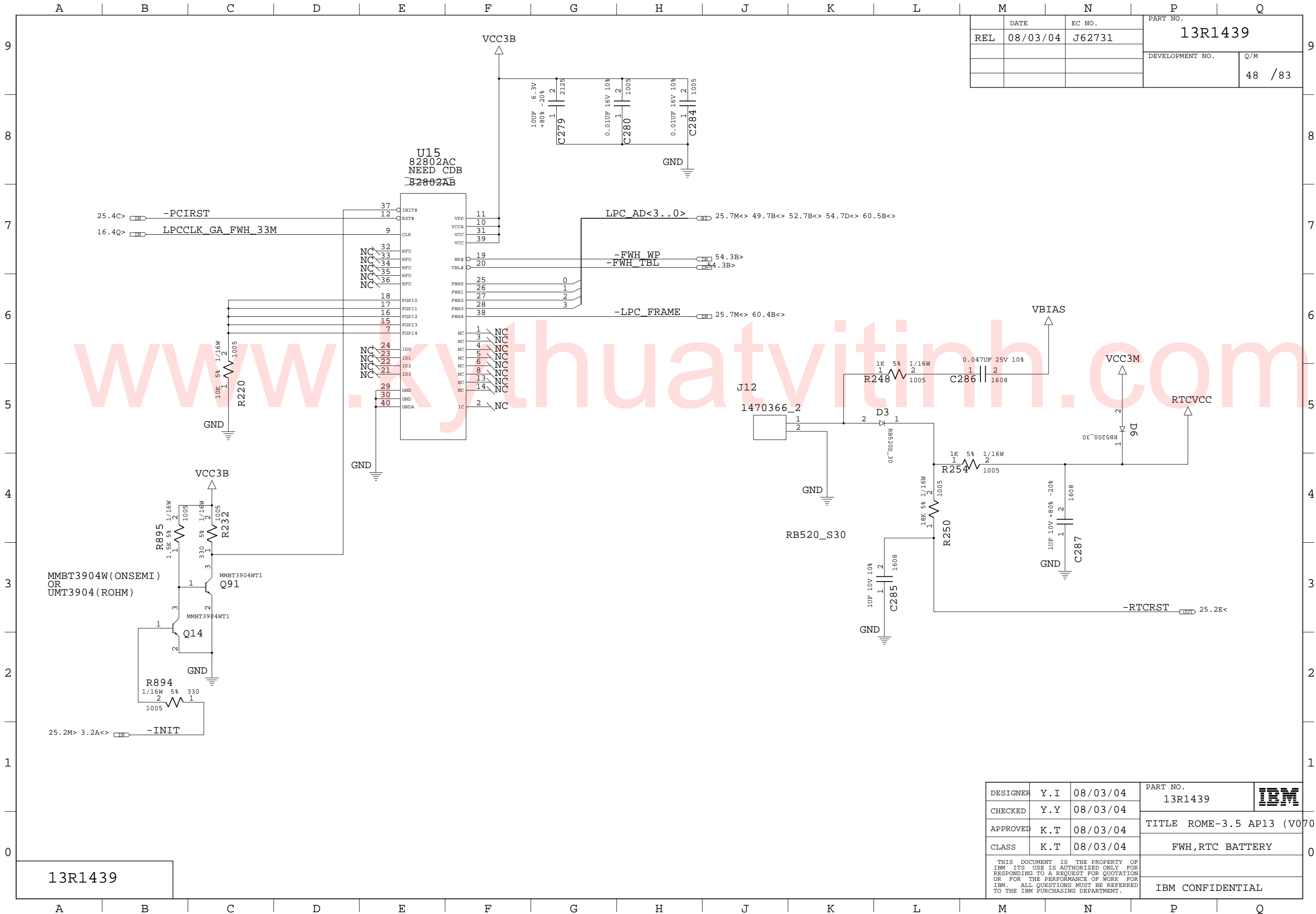

REL	08/03/04	EC NO.	J62731	PART NO.	13R1439
				DEVELOPMENT NO.	Q/M
					48 / 83

DESIGNER	Y.I	08/03/04	PART NO.	13R1439	<b>IBM</b>
CHECKED	Y.Y	08/03/04	TITLE	ROME-3.5 AP13 (V070)	
APPROVED	K.T	08/03/04	CLASS	FWH,RTC BATTERY	
THIS DOCUMENT IS THE PROPERTY OF IBM. ITS USE IS AUTHORIZED ONLY FOR RESPONDING TO A REQUEST FOR QUOTATION OR FOR THE PERFORMANCE OF WORK FOR IBM. ALL QUESTIONS MUST BE REFERRED TO THE IBM PURCHASING DEPARTMENT.					IBM CONFIDENTIAL

13R1439



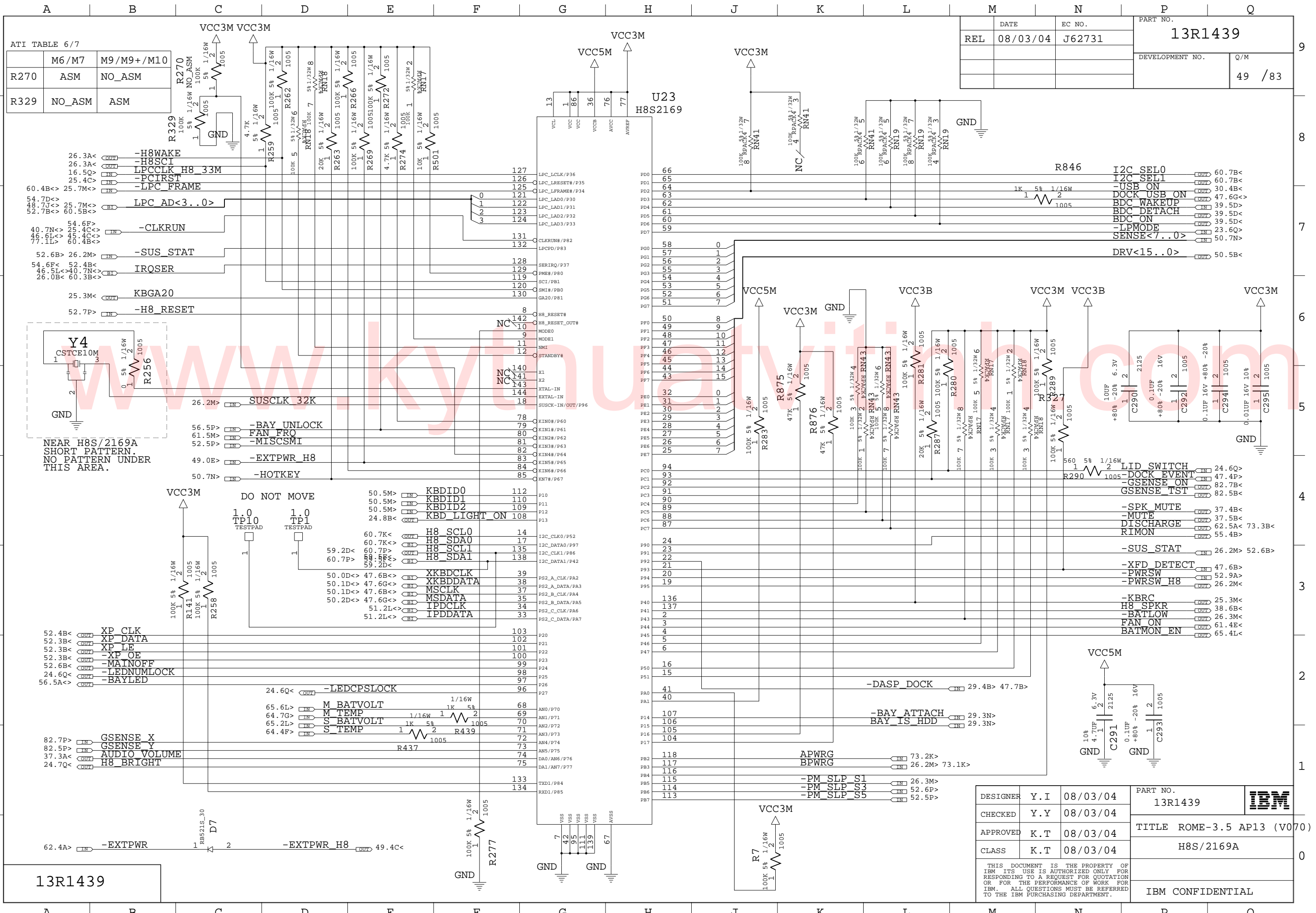

ATI TABLE 6/7

M6/M7	M9/M9+/M10
R270	ASM NO_ASM
R329	NO_ASM ASM

DATE	EC NO.	PART NO.
08/03/04	J62731	13R1439
DEVELOPMENT NO.		Q/M
		49 /83

NEAR H8S/2169A  
SHORT PATTERN.  
NO PATTERN UNDER  
THIS AREA.

DESIGNER	Y.I	08/03/04	PART NO.	13R1439	
CHECKED	Y.Y	08/03/04	TITLE ROME-3.5 AP13 (V070)		
APPROVED	K.T	08/03/04	H8S/2169A		IBM CONFIDENTIAL
CLASS	K.T	08/03/04			

THIS DOCUMENT IS THE PROPERTY OF IBM. ITS USE IS AUTHORIZED ONLY FOR RESPONDING TO A REQUEST FOR QUOTATION OR FOR THE PERFORMANCE OF WORK FOR IBM. ALL QUESTIONS MUST BE REFERRED TO THE IBM PURCHASING DEPARTMENT.

13R1439

REL	DATE	EC NO.	PART NO.
	08/03/04	J62731	13R1439
			DEVELOPMENT NO.
			Q/M
			50 / 83

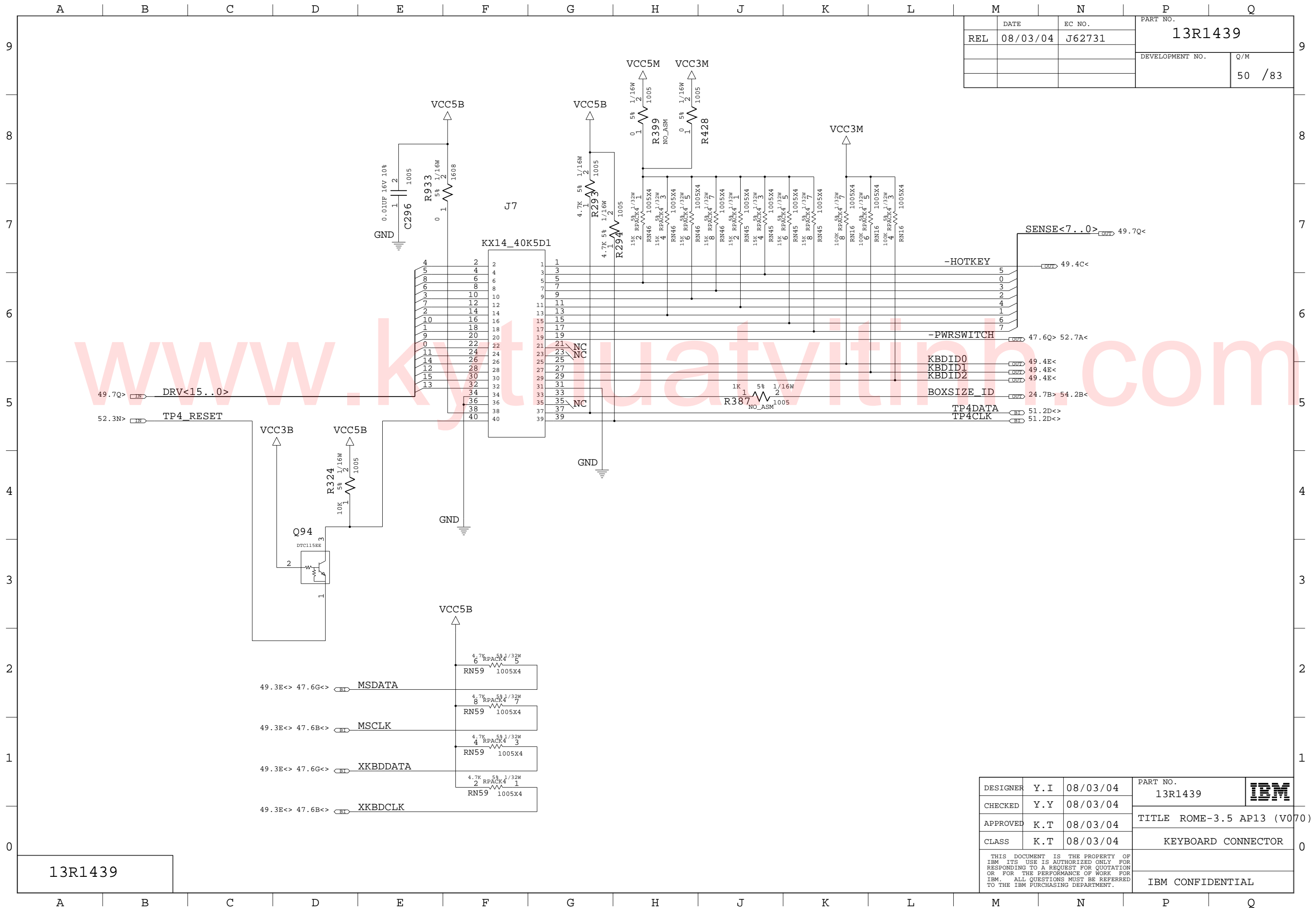

13R1439

DESIGNER	Y.I	08/03/04	PART NO.	13R1439	
CHECKED	Y.Y	08/03/04			
APPROVED	K.T	08/03/04	TITLE ROME-3.5 AP13 (V070)		
CLASS	K.T	08/03/04	KEYBOARD CONNECTOR		
THIS DOCUMENT IS THE PROPERTY OF IBM. ITS USE IS AUTHORIZED ONLY FOR RESPONDING TO A REQUEST FOR QUOTATION OR FOR THE PERFORMANCE OF WORK FOR IBM. ALL QUESTIONS MUST BE REFERRED TO THE IBM PURCHASING DEPARTMENT.					IBM CONFIDENTIAL

	DATE	EC NO.	PART NO.	
REL	08/03/04	J62731	13R1439	
			DEVELOPMENT NO.	Q/M
				51 /83

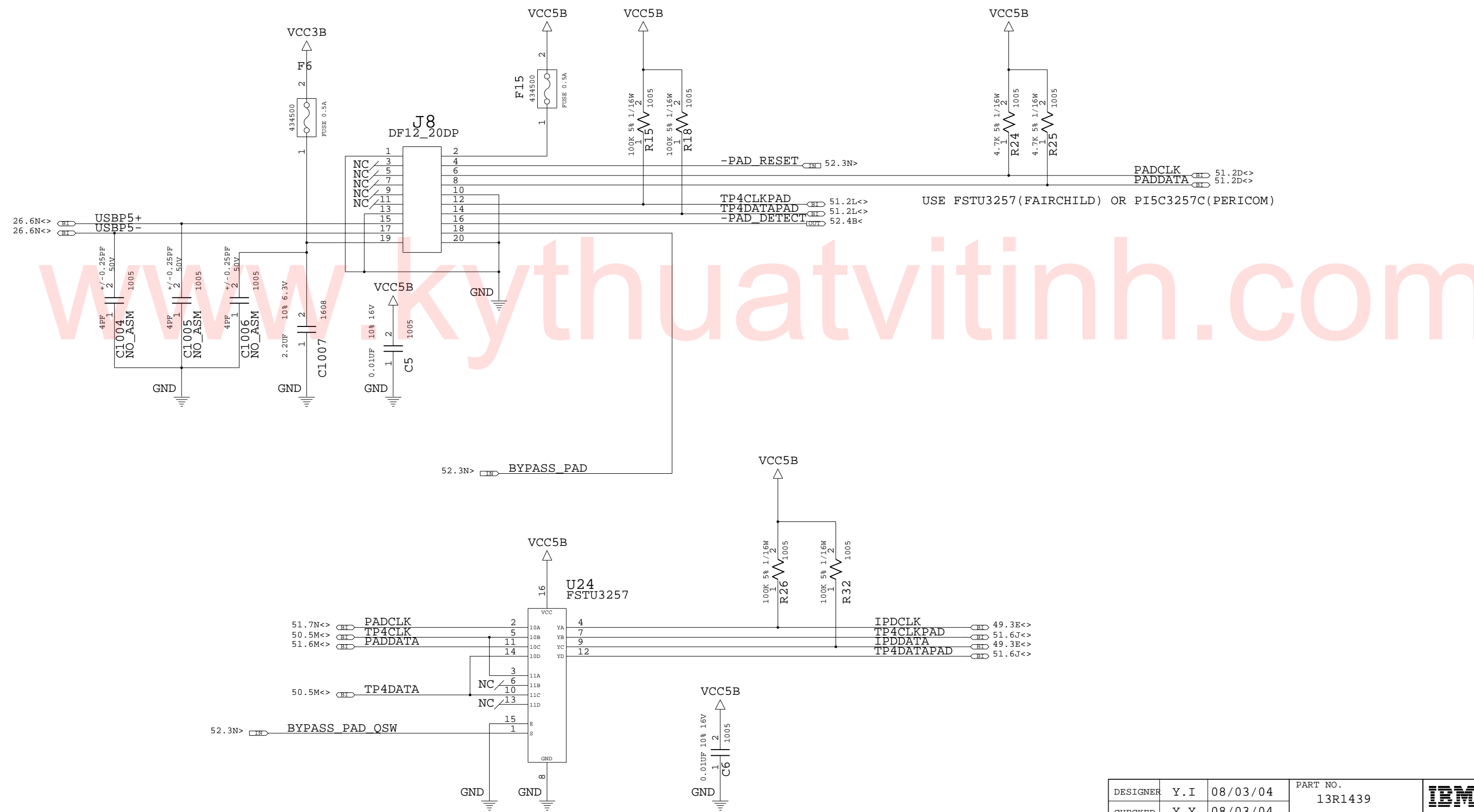

13R1439

DESIGNER	Y.I	08/03/04	PART NO.	13R1439	
CHECKED	Y.Y	08/03/04			
APPROVED	K.T	08/03/04	TITLE ROME-3.5 AP13 (V070)		
CLASS	K.T	08/03/04	TOUCH PAD CONNECTOR		
THIS DOCUMENT IS THE PROPERTY OF IBM. ITS USE IS AUTHORIZED ONLY FOR RESPONDING TO A REQUEST FOR QUOTATION OR FOR THE PERFORMANCE OF WORK FOR IBM. ALL QUESTIONS MUST BE REFERRED TO THE IBM PURCHASING DEPARTMENT.					IBM CONFIDENTIAL

DATE	EC NO.	PART NO.	
REL 08/03/04	J62731	13R1439	
		DEVELOPMENT NO.	Q/M
			52 / 83

	M6/M7/M9	M10
R322	ASM	NO-ASM
R408	NO-ASM	ASM

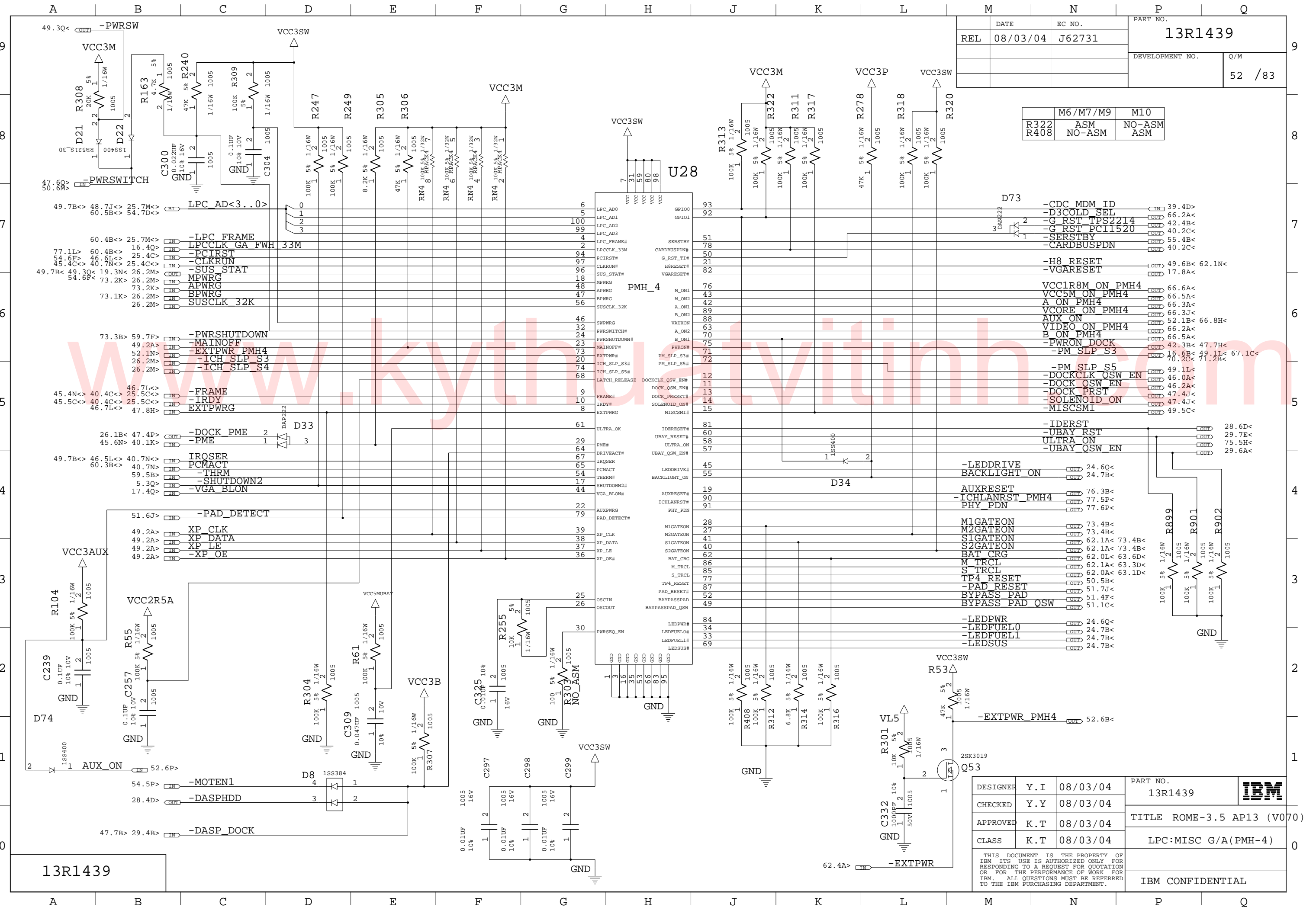

	DATE	EC NO.	PART NO.	
REL	08/03/04	J62731	13R1439	
			DEVELOPMENT NO.	Q/M
				53 /83

ADDITIONAL CAPS FOR VINT16 OF VCCCPUCORE.

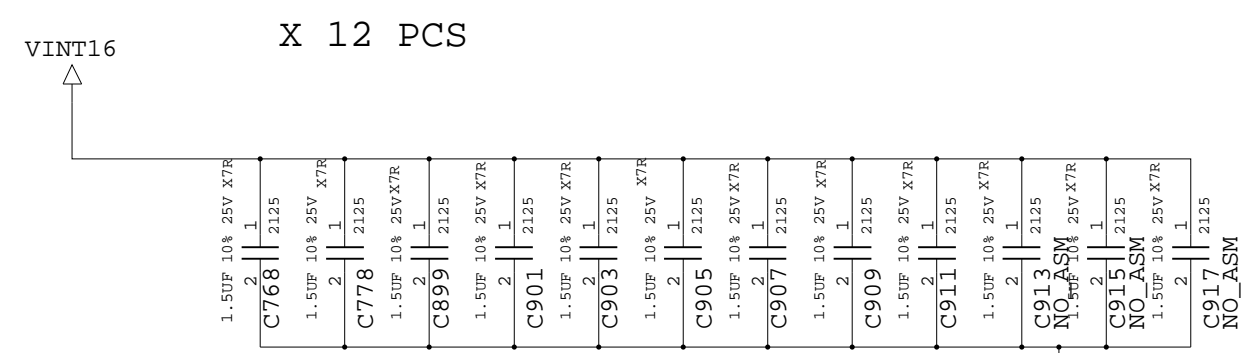
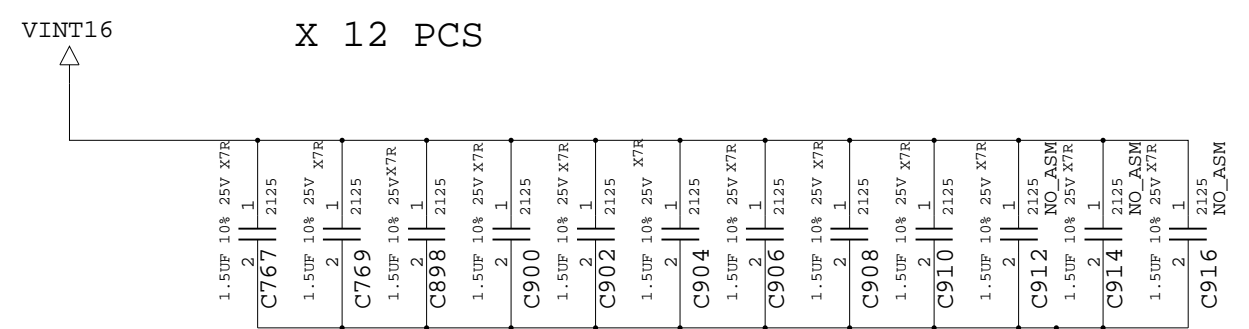

13R1439

DESIGNER	Y.I	08/03/04	PART NO.	13R1439	
CHECKED	Y.Y	08/03/04			
APPROVED	K.T	08/03/04	TITLE ROME-3.5 AP13 (V070)		
CLASS	K.T	08/03/04	VCCCPUCORE DECAP		
<small>THIS DOCUMENT IS THE PROPERTY OF IBM. ITS USE IS AUTHORIZED ONLY FOR RESPONDING TO A REQUEST FOR QUOTATION OR FOR THE PERFORMANCE OF WORK FOR IBM. ALL QUESTIONS MUST BE REFERRED TO THE IBM PURCHASING DEPARTMENT.</small>					IBM CONFIDENTIAL

DATE	EC NO.	PART NO.	
REL 08/03/04	J62731	13R1439	
		DEVELOPMENT NO.	Q/M
			54 / 83

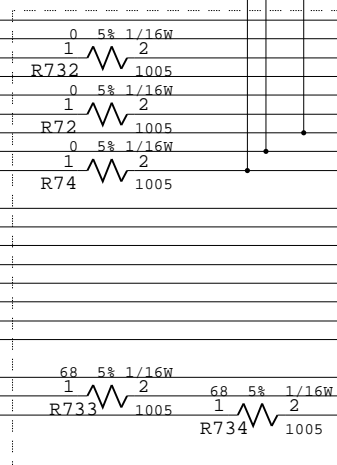
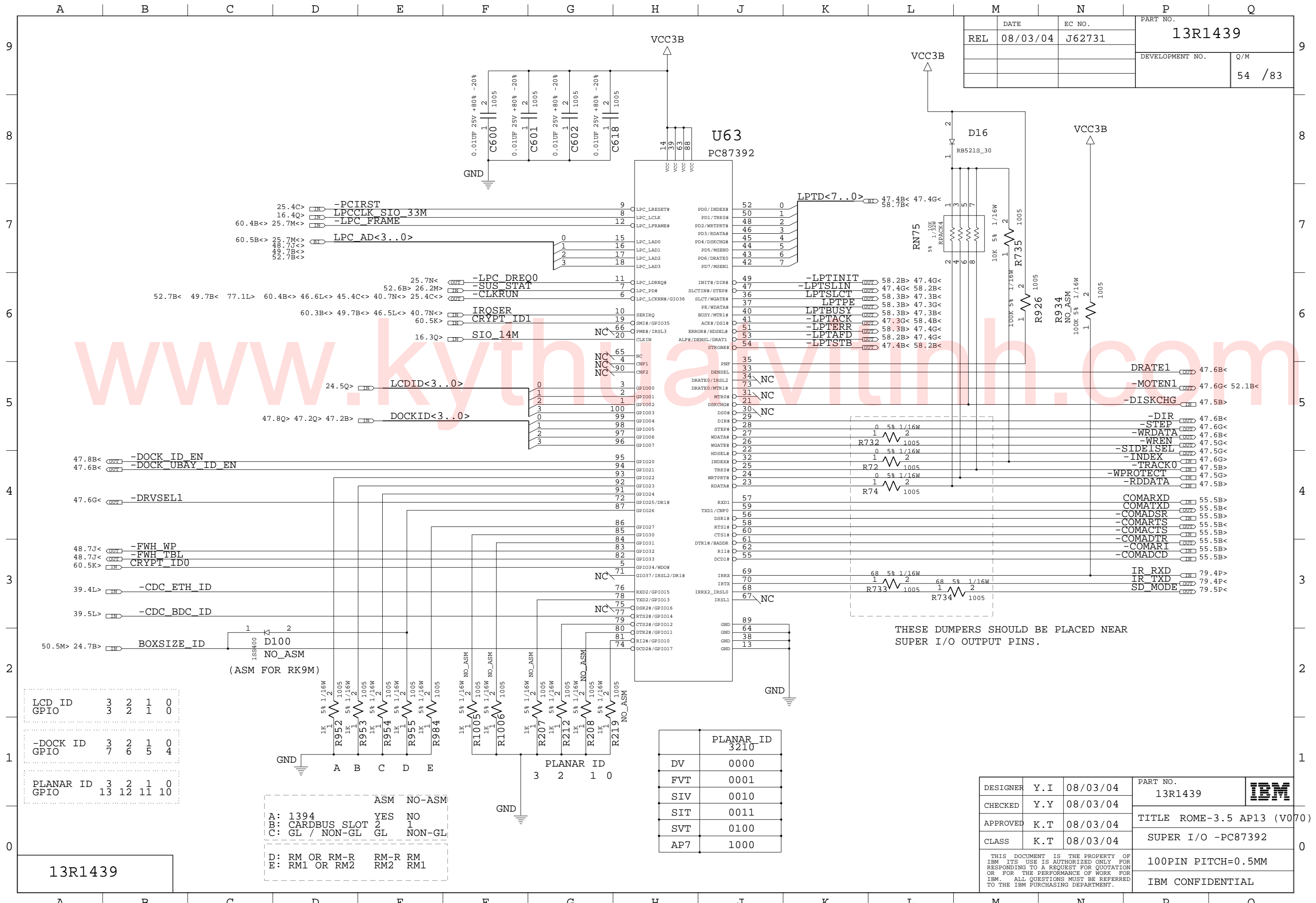

THESE DUMPERS SHOULD BE PLACED NEAR SUPER I/O OUTPUT PINS.

	PLANAR_ID
DV	0000
FVT	0001
SIV	0010
SIT	0011
SVT	0100
AP7	1000

DESIGNER	Y.I	08/03/04	PART NO.	13R1439	
CHECKED	Y.Y	08/03/04			
APPROVED	K.T	08/03/04	TITLE ROME-3.5 AP13 (V070)		
CLASS	K.T	08/03/04	SUPER I/O -PC87392		
THIS DOCUMENT IS THE PROPERTY OF IBM. ITS USE IS AUTHORIZED ONLY FOR RESPONDING TO A REQUEST FOR QUOTATION OR FOR THE PERFORMANCE OF WORK FOR IBM. ALL QUESTIONS MUST BE REFERRED TO THE IBM PURCHASING DEPARTMENT.					100PIN PITCH=0.5MM
					IBM CONFIDENTIAL

	ASM	NO-ASM
A: 1394	YES	NO
B: CARDBUS SLOT 2	1	1
C: GL / NON-GL	GL	NON-GL
D: RM OR RM-R	RM-R	RM
E: RM1 OR RM2	RM2	RM1

13R1439

	DATE	EC NO.	PART NO.	
REL	08/03/04	J62731	13R1439	
			DEVELOPMENT NO.	Q/M
				55 /83

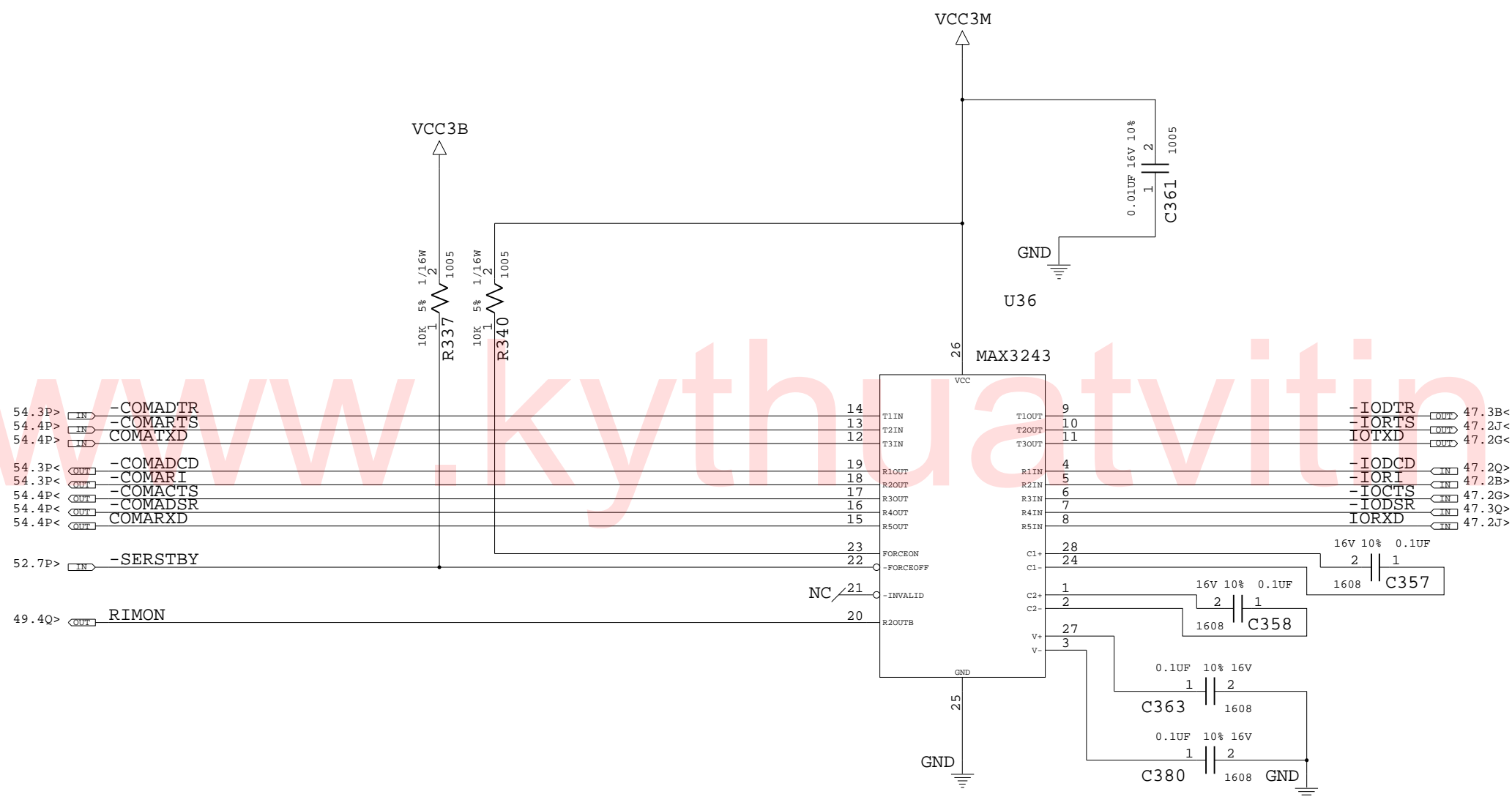

R1IN/R2IN/R3IN/R5IN HAVE INTERNAL PULLDOWN(5K OHM).  
DO NOT WIRE SIGNALS UNDER PINS (1/2/3/24/25/26/27/28)  
CHARGE PUMP CAPACITOR SHOULD BE PLACED NEAR PINS(1/2/3/24/27/28)  
ADD GND SHILED UNDER CHARGE PUMP CIRCUIT TO  
PROTECT POWER LINE NOISE  
CAPACITORS FOR CHARGE PUMP SHOULD BE USED TYPE B AND LOW ESR TYPE.

	NORMAL MODE	POWER DOWN MODE	AUTO POWER DOWN MODE
FORCEON	HIGH	DO NOT CARE	LOW
FOCEOFF	HIGH	LOW	HIGH

13R1439

DESIGNER	Y.I	08/03/04	PART NO.	13R1439	IBM
CHECKED	Y.Y	08/03/04	TITLE		
APPROVED	K.T	08/03/04	CLASS	SERIAL INTERFACE	
THIS DOCUMENT IS THE PROPERTY OF IBM. ITS USE IS AUTHORIZED ONLY FOR RESPONDING TO A REQUEST FOR QUOTATION OR FOR THE PERFORMANCE OF WORK FOR IBM. ALL QUESTIONS MUST BE REFERRED TO THE IBM PURCHASING DEPARTMENT.				IBM CONFIDENTIAL	

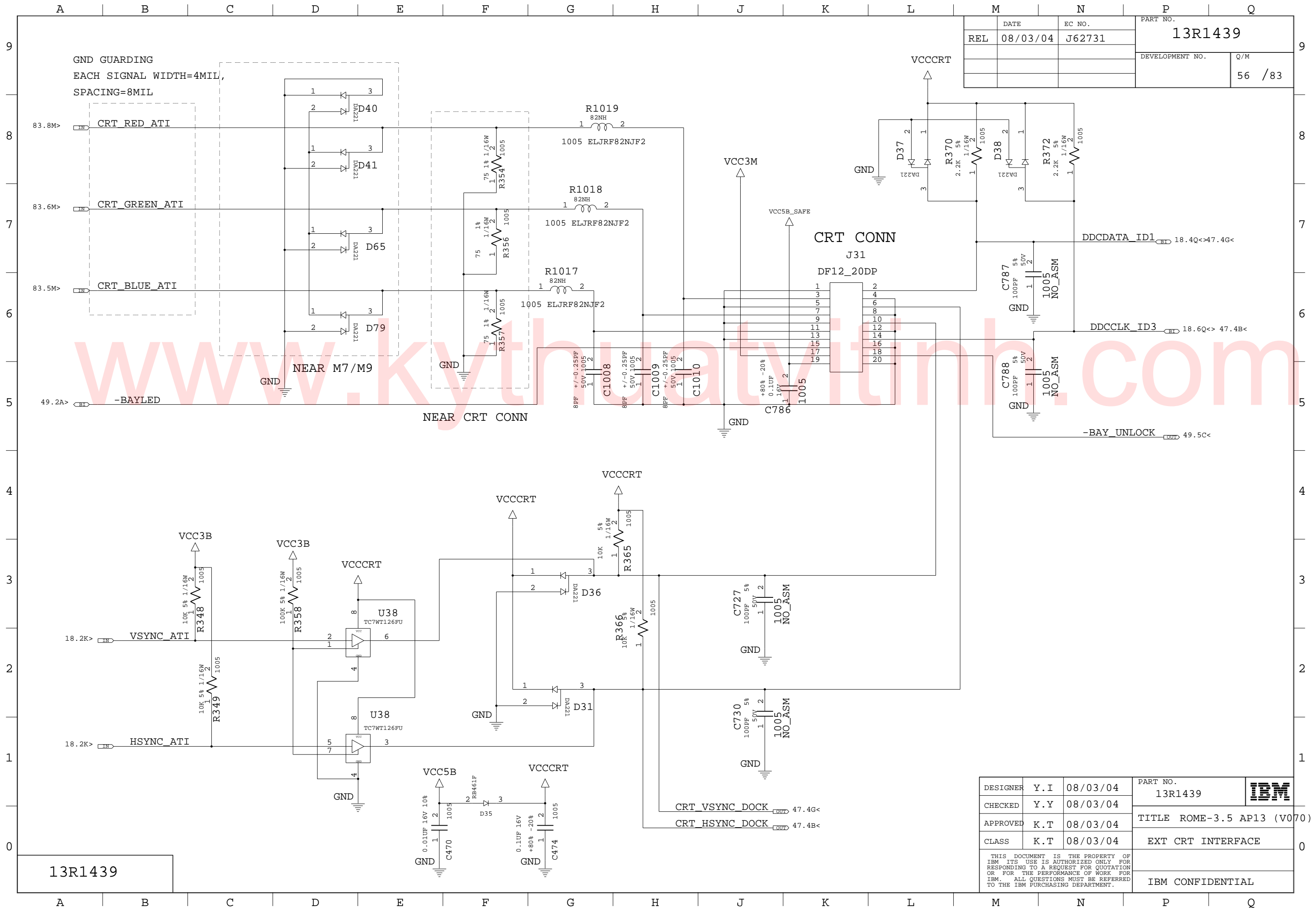

DATE	EC NO.	PART NO.	
REL 08/03/04	J62731	13R1439	
		DEVELOPMENT NO.	Q/M
			56 / 83

13R1439

DESIGNER	Y.I	08/03/04	PART NO.	13R1439	
CHECKED	Y.Y	08/03/04	TITLE		
APPROVED	K.T	08/03/04		EXT CRT INTERFACE	
CLASS	K.T	08/03/04			
THIS DOCUMENT IS THE PROPERTY OF IBM. ITS USE IS AUTHORIZED ONLY FOR RESPONDING TO A REQUEST FOR QUOTATION OR FOR THE PERFORMANCE OF WORK FOR IBM. ALL QUESTIONS MUST BE REFERRED TO THE IBM PURCHASING DEPARTMENT.					IBM CONFIDENTIAL



	DATE	EC NO.	PART NO.	
REL	08/03/04	J62731	13R1439	
			DEVELOPMENT NO.	Q/M
				57 /83

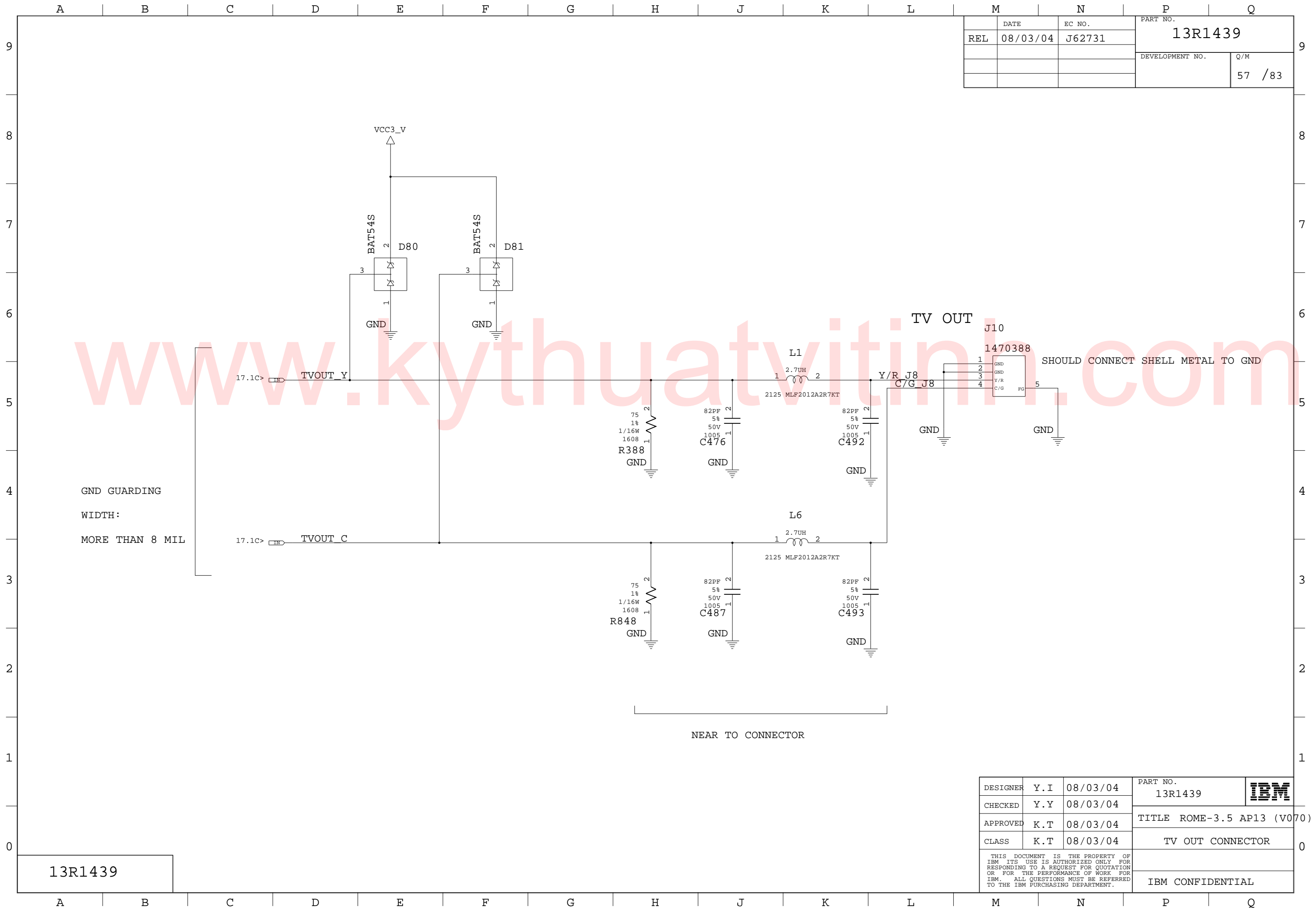

GND GUARDING  
WIDTH:  
MORE THAN 8 MIL

SHOULD CONNECT SHELL METAL TO GND

NEAR TO CONNECTOR

13R1439

DESIGNER	Y.I	08/03/04	PART NO.	13R1439	<b>IBM</b>
CHECKED	Y.Y	08/03/04			
APPROVED	K.T	08/03/04	TITLE ROME-3.5 AP13 (V070)		
CLASS	K.T	08/03/04	TV OUT CONNECTOR		
THIS DOCUMENT IS THE PROPERTY OF IBM. ITS USE IS AUTHORIZED ONLY FOR RESPONDING TO A REQUEST FOR QUOTATION OR FOR THE PERFORMANCE OF WORK FOR IBM. ALL QUESTIONS MUST BE REFERRED TO THE IBM PURCHASING DEPARTMENT.				IBM CONFIDENTIAL	

REL	DATE 08/03/04	EC NO. J62731	PART NO. 13R1439
			DEVELOPMENT NO. Q/M 58 /83

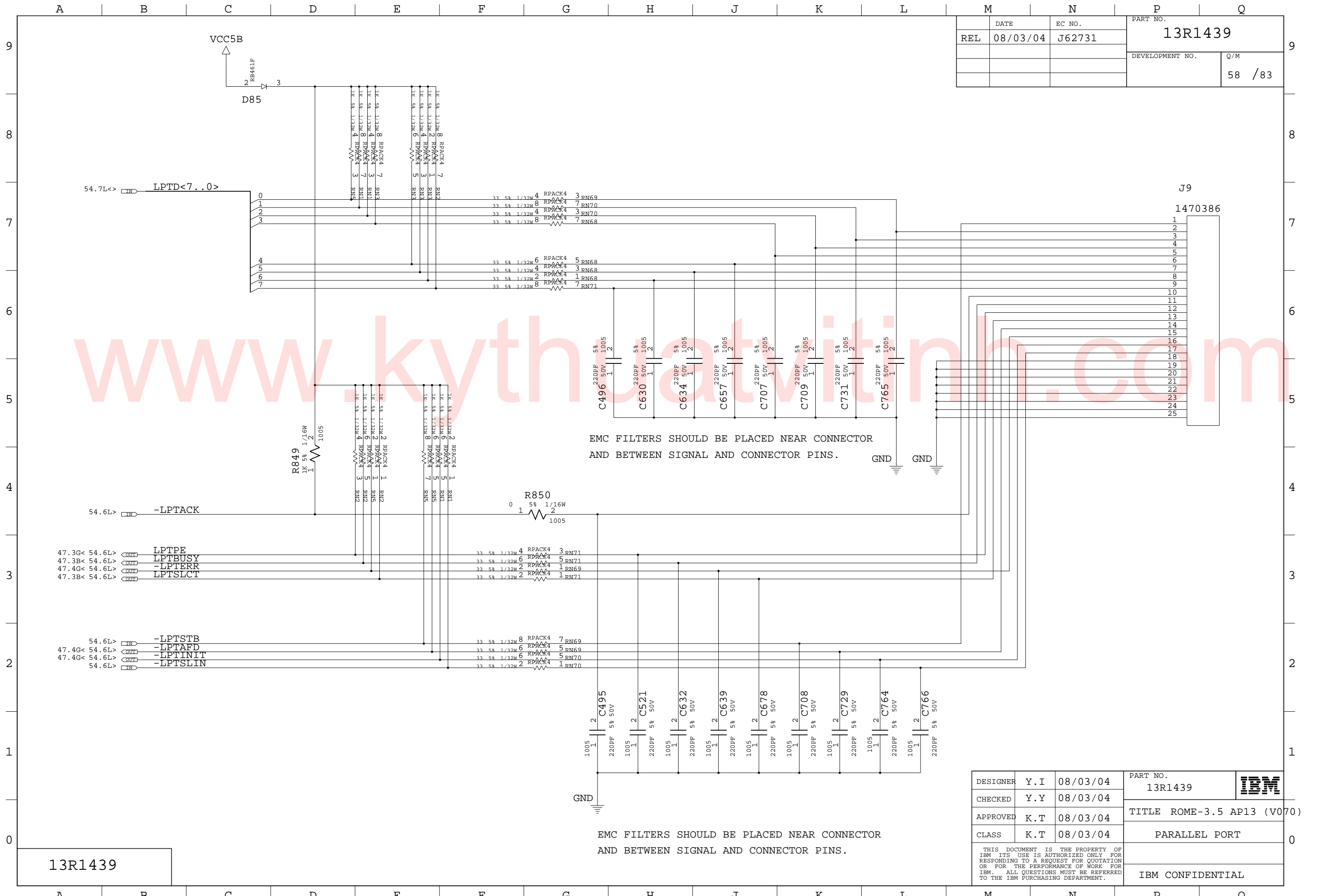

EMC FILTERS SHOULD BE PLACED NEAR CONNECTOR AND BETWEEN SIGNAL AND CONNECTOR PINS.

EMC FILTERS SHOULD BE PLACED NEAR CONNECTOR AND BETWEEN SIGNAL AND CONNECTOR PINS.

DESIGNER	Y.I	08/03/04	PART NO. 13R1439	
CHECKED	Y.Y	08/03/04	TITLE ROME-3.5 AP13 (V070)	
APPROVED	K.T	08/03/04	PARALLEL PORT	IBM CONFIDENTIAL
CLASS	K.T	08/03/04		

13R1439



DATE	EC NO.	PART NO.	
REL 08/03/04	J62731	13R1439	
		DEVELOPMENT NO.	Q/M
			60 / 83

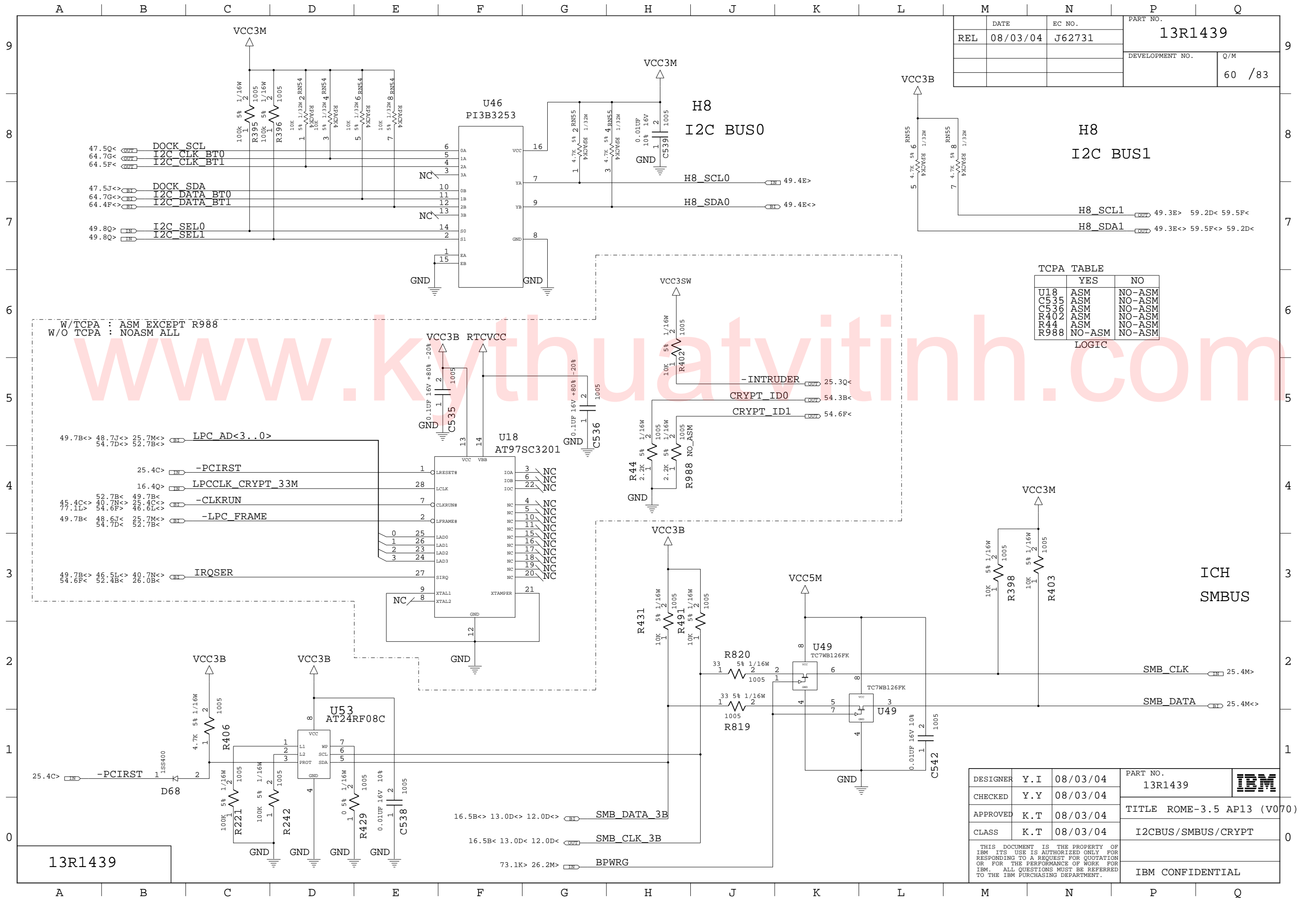

W/TCPA : ASM EXCEPT R988  
W/O TCPA : NOASM ALL

TCPA TABLE

	YES	NO
U18	ASM	NO-ASM
C535	ASM	NO-ASM
C536	ASM	NO-ASM
R402	ASM	NO-ASM
R44	ASM	NO-ASM
R988	NO-ASM	NO-ASM

LOGIC

13R1439

DESIGNER	Y.I	08/03/04	PART NO.	13R1439	
CHECKED	Y.Y	08/03/04			
APPROVED	K.T	08/03/04	TITLE ROME-3.5 AP13 (V070)		
CLASS	K.T	08/03/04	I2CBUS/SMBUS/CRYPT		
THIS DOCUMENT IS THE PROPERTY OF IBM. ITS USE IS AUTHORIZED ONLY FOR RESPONDING TO A REQUEST FOR QUOTATION OR FOR THE PERFORMANCE OF WORK FOR IBM. ALL QUESTIONS MUST BE REFERRED TO THE IBM PURCHASING DEPARTMENT.					IBM CONFIDENTIAL

	DATE	EC NO.	PART NO.	
REL	08/03/04	J62731	13R1439	
			DEVELOPMENT NO.	Q/M
				61 /83

FAN FUSE TABLE 1/1

	M7/M9	M10
F4	0.5 A	2.0 A

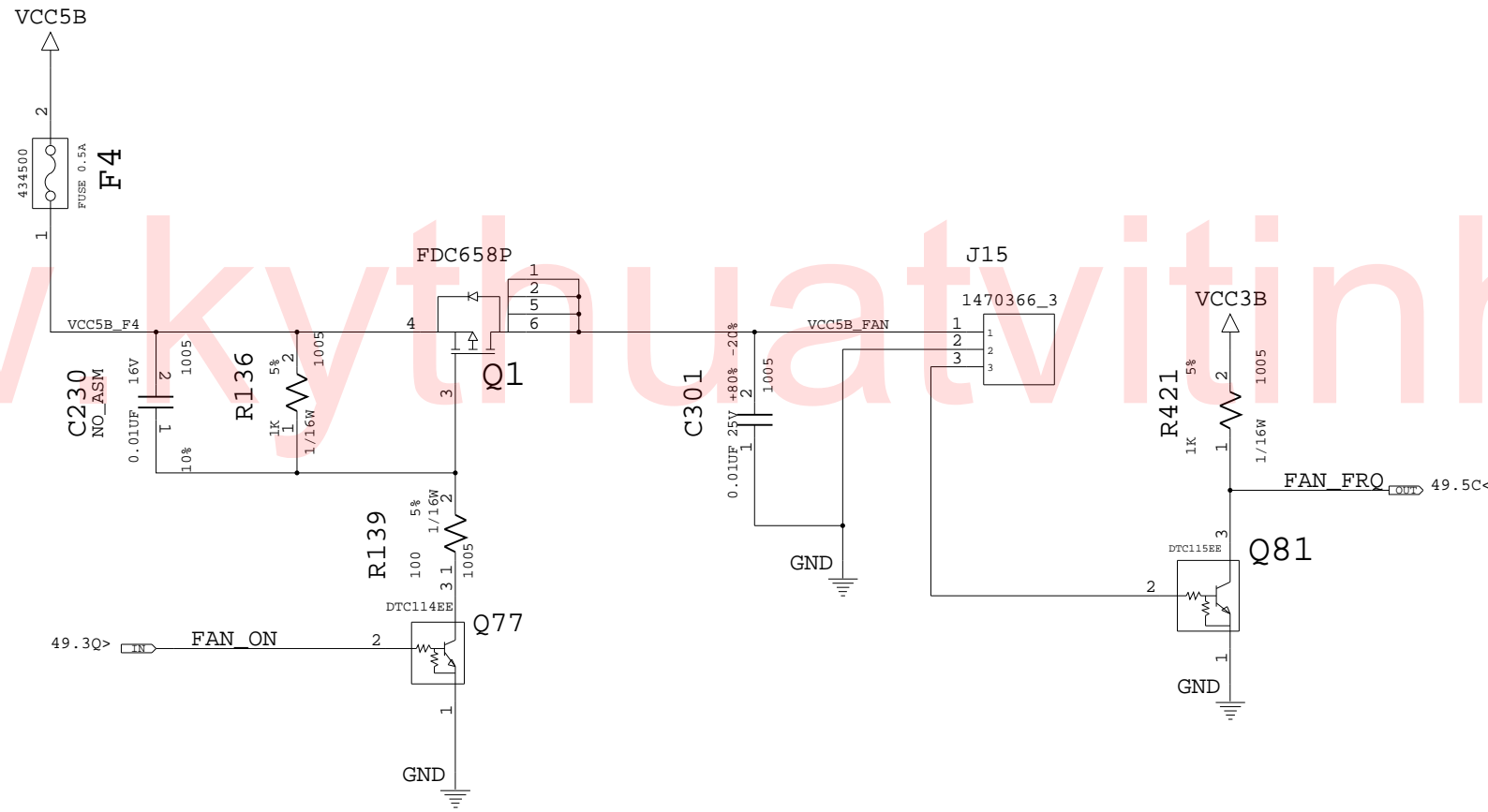

13R1439

DESIGNER	Y.I	08/03/04	PART NO.	13R1439	
CHECKED	Y.Y	08/03/04			
APPROVED	K.T	08/03/04	TITLE ROME-3.5 AP13 (V070)		
CLASS	K.T	08/03/04	FAN CONNECTOR		
THIS DOCUMENT IS THE PROPERTY OF IBM. ITS USE IS AUTHORIZED ONLY FOR RESPONDING TO A REQUEST FOR QUOTATION OR FOR THE PERFORMANCE OF WORK FOR IBM. ALL QUESTIONS MUST BE REFERRED TO THE IBM PURCHASING DEPARTMENT.				IBM CONFIDENTIAL	



	DATE	EC NO.	PART NO.	
REL	08/03/04	J62731	13R1439	
			DEVELOPMENT NO.	Q/M
				63 /83

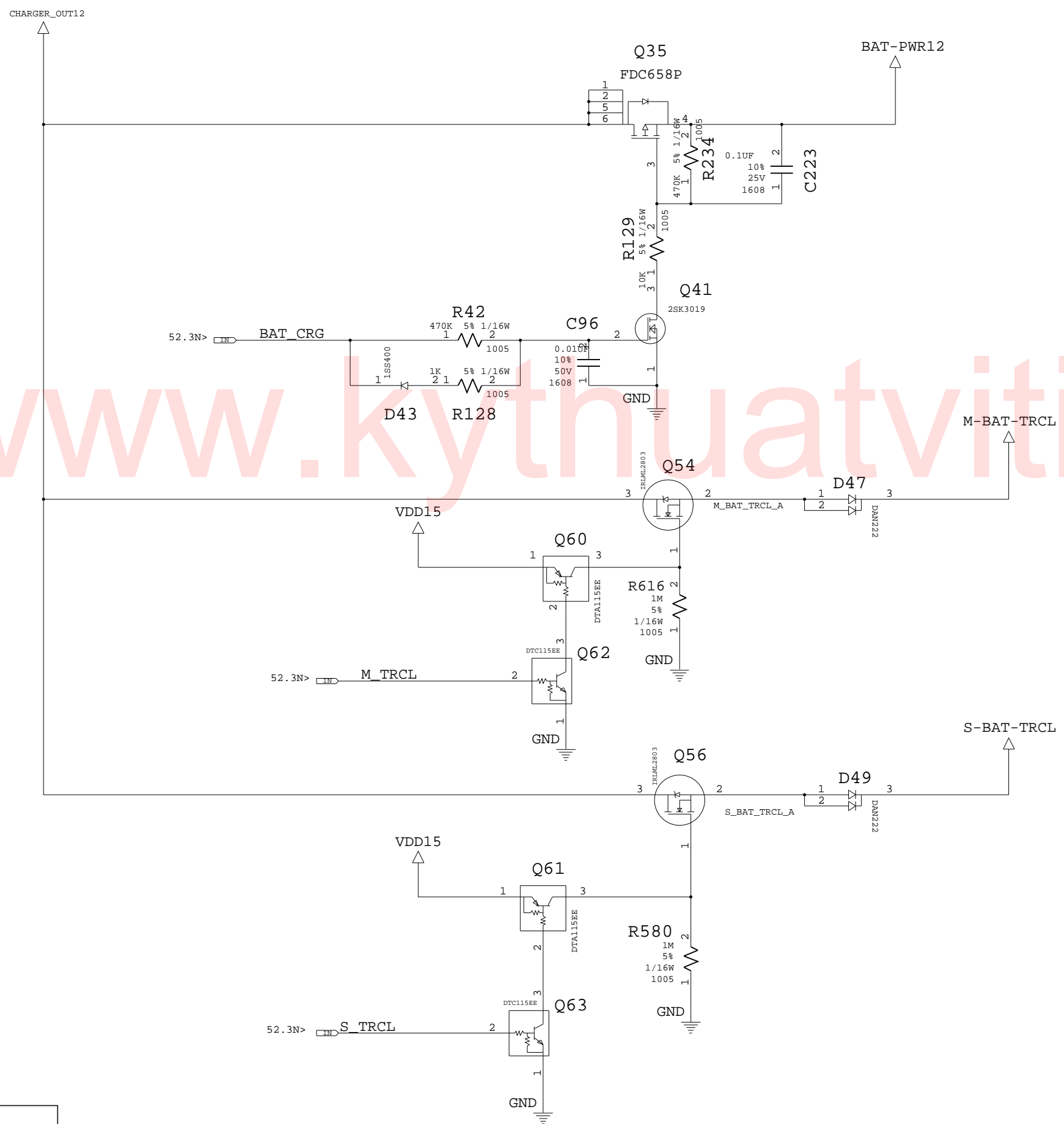

13R1439

DESIGNER	Y.I	08/03/04	PART NO.	13R1439	
CHECKED	Y.Y	08/03/04	TITLE		
APPROVED	K.T	08/03/04	CHARGE SELECTOR		
CLASS	K.T	08/03/04	IBM CONFIDENTIAL		

THIS DOCUMENT IS THE PROPERTY OF IBM. ITS USE IS AUTHORIZED ONLY FOR RESPONDING TO A REQUEST FOR QUOTATION OR FOR THE PERFORMANCE OF WORK FOR IBM. ALL QUESTIONS MUST BE REFERRED TO THE IBM PURCHASING DEPARTMENT.

REL	DATE	EC NO.	PART NO.
	08/03/04	J62731	13R1439
			DEVELOPMENT NO.
			Q/M
			64 / 83

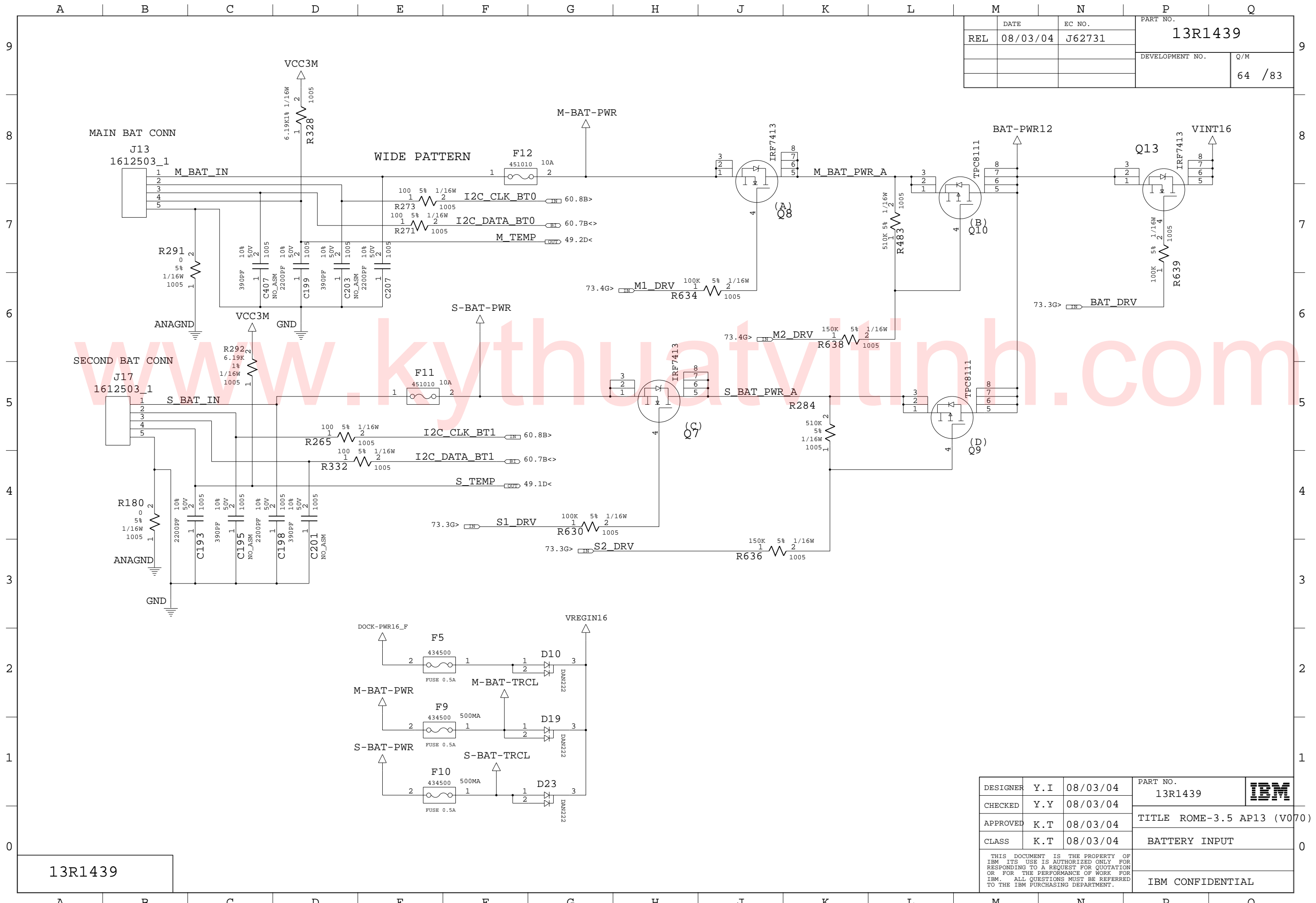

13R1439

DESIGNER	Y.I	08/03/04	PART NO.	13R1439	
CHECKED	Y.Y	08/03/04	TITLE		
APPROVED	K.T	08/03/04	CLASS	BATTERY INPUT	
THIS DOCUMENT IS THE PROPERTY OF IBM. ITS USE IS AUTHORIZED ONLY FOR RESPONDING TO A REQUEST FOR QUOTATION OR FOR THE PERFORMANCE OF WORK FOR IBM. ALL QUESTIONS MUST BE REFERRED TO THE IBM PURCHASING DEPARTMENT.				IBM CONFIDENTIAL	



	DATE	EC NO.	PART NO.	
REL	08/03/04	J62731	13R1439	
			DEVELOPMENT NO.	Q/M
				65 /83

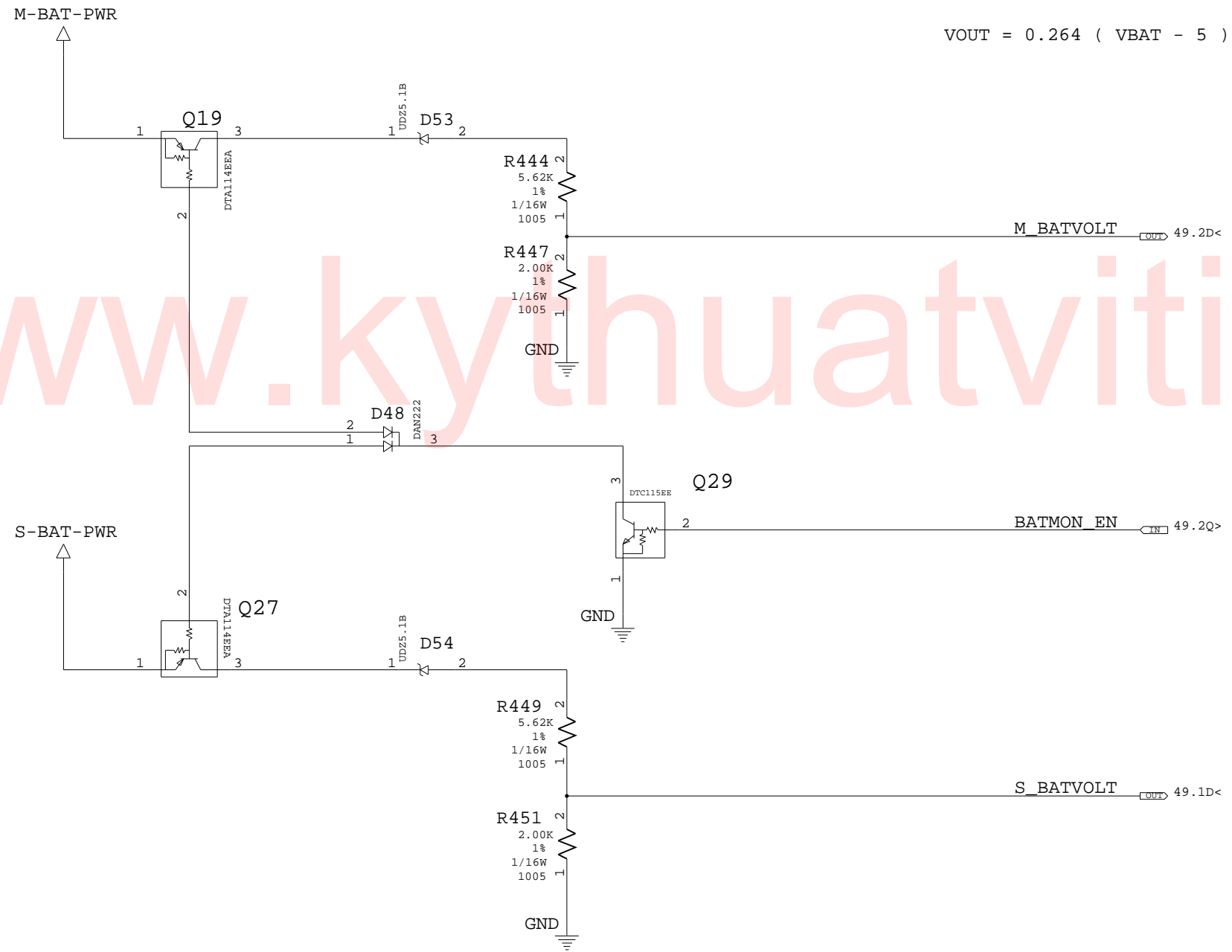

www.kyathuatvithinh.com

13R1439

DESIGNER	Y.I	08/03/04	PART NO.	13R1439	
CHECKED	Y.Y	08/03/04			
APPROVED	K.T	08/03/04	TITLE ROME-3.5 AP13 (V070)		
CLASS	K.T	08/03/04	BATTERY MONITOR		
THIS DOCUMENT IS THE PROPERTY OF IBM. ITS USE IS AUTHORIZED ONLY FOR RESPONDING TO A REQUEST FOR QUOTATION OR FOR THE PERFORMANCE OF WORK FOR IBM. ALL QUESTIONS MUST BE REFERRED TO THE IBM PURCHASING DEPARTMENT.				IBM CONFIDENTIAL	

	DATE	EC NO.	PART NO.	
REL	08/03/04	J62731	13R1439	
			DEVELOPMENT NO.	Q/M
				66 /83

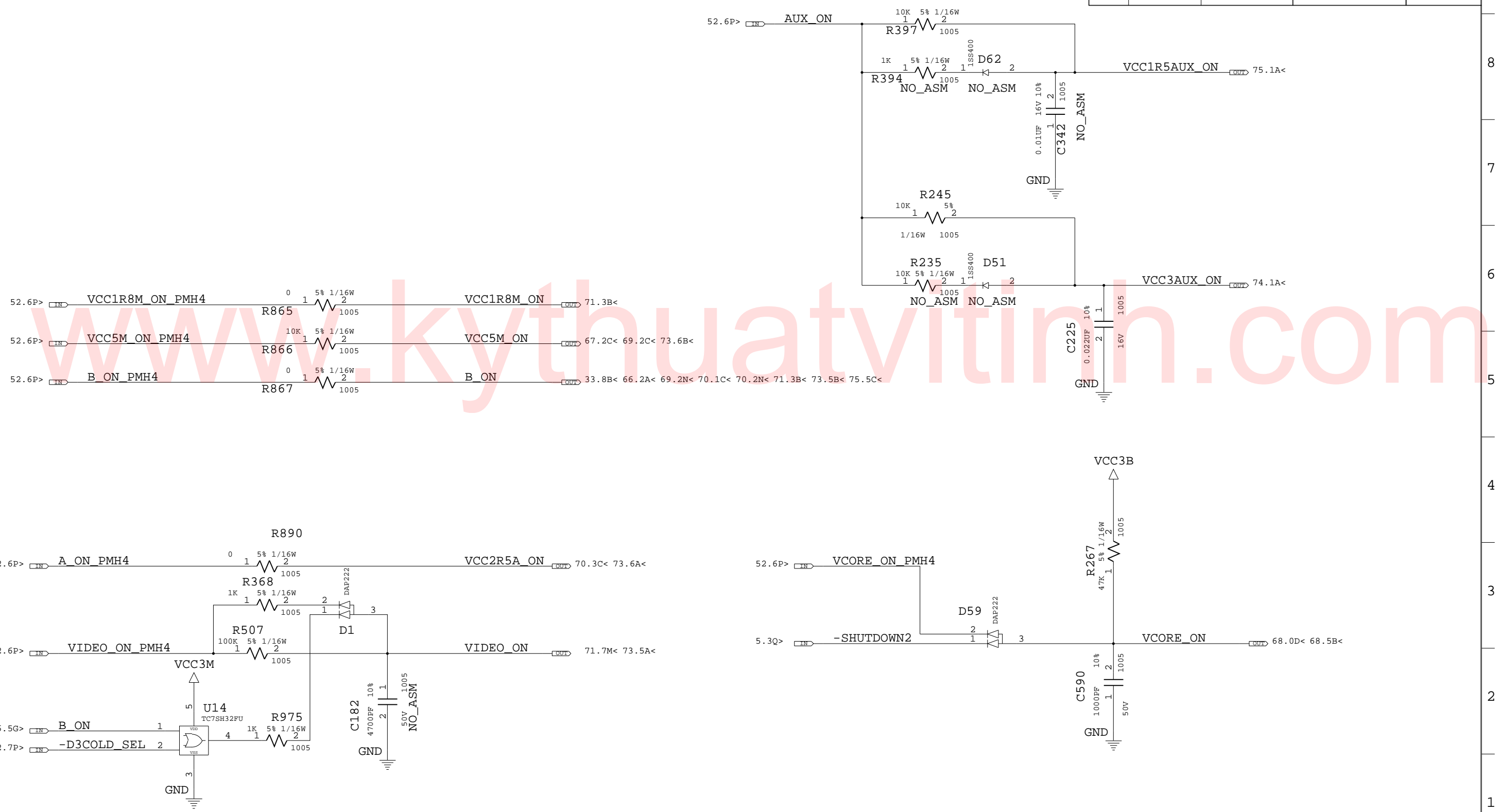

13R1439

DESIGNER	Y.I	08/03/04	PART NO.	13R1439	<b>IBM</b>
CHECKED	Y.Y	08/03/04			
APPROVED	K.T	08/03/04	TITLE ROME-3.5 AP13 (V070)		
CLASS	K.T	08/03/04	POWER SEQUENCE		
THIS DOCUMENT IS THE PROPERTY OF IBM. ITS USE IS AUTHORIZED ONLY FOR RESPONDING TO A REQUEST FOR QUOTATION OR FOR THE PERFORMANCE OF WORK FOR IBM. ALL QUESTIONS MUST BE REFERRED TO THE IBM PURCHASING DEPARTMENT.				IBM CONFIDENTIAL	

	M6/M7/M9/M9+/M10	M9GL/M10GL
R987	NO-ASM	ASM
L4	CDRH104R_10UH_4R4A	CDRH104R_5R2UH_5R5A
Q100	NO-ASM	ASM
C240	NO-ASM	ASM

REL	DATE	EC NO.	PART NO.
	08/03/04	J62731	13R1439
			DEVELOPMENT NO.
			Q/M
			67 / 83

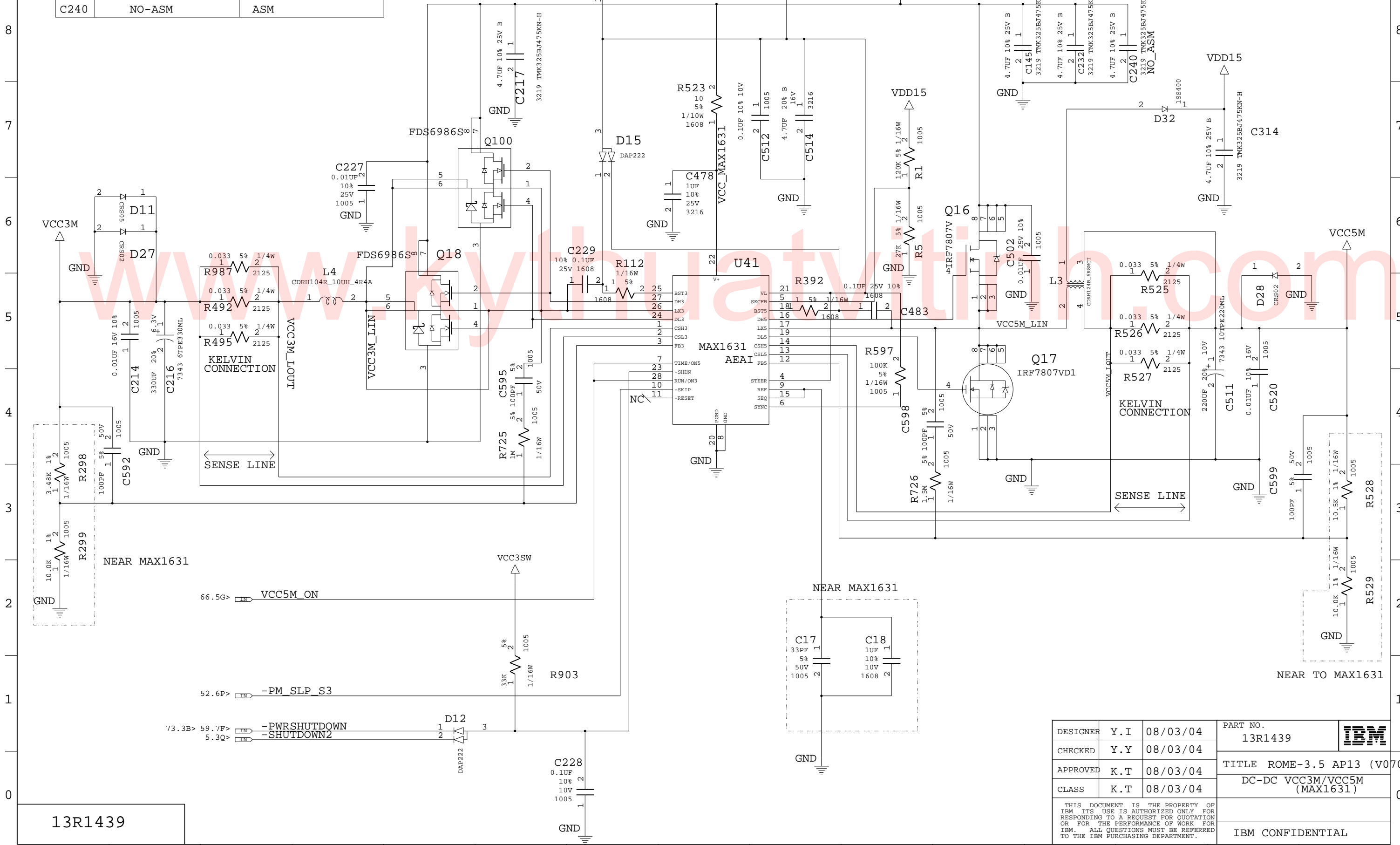

13R1439

DESIGNER	Y.I	08/03/04	PART NO.	13R1439	
CHECKED	Y.Y	08/03/04	TITLE	ROME-3.5 AP13 (V070)	
APPROVED	K.T	08/03/04	CLASS	DC-DC VCC3M/VCC5M (MAX1631)	IBM CONFIDENTIAL
THIS DOCUMENT IS THE PROPERTY OF IBM. ITS USE IS AUTHORIZED ONLY FOR RESPONDING TO A REQUEST FOR QUOTATION OR FOR THE PERFORMANCE OF WORK FOR IBM. ALL QUESTIONS MUST BE REFERRED TO THE IBM PURCHASING DEPARTMENT.					

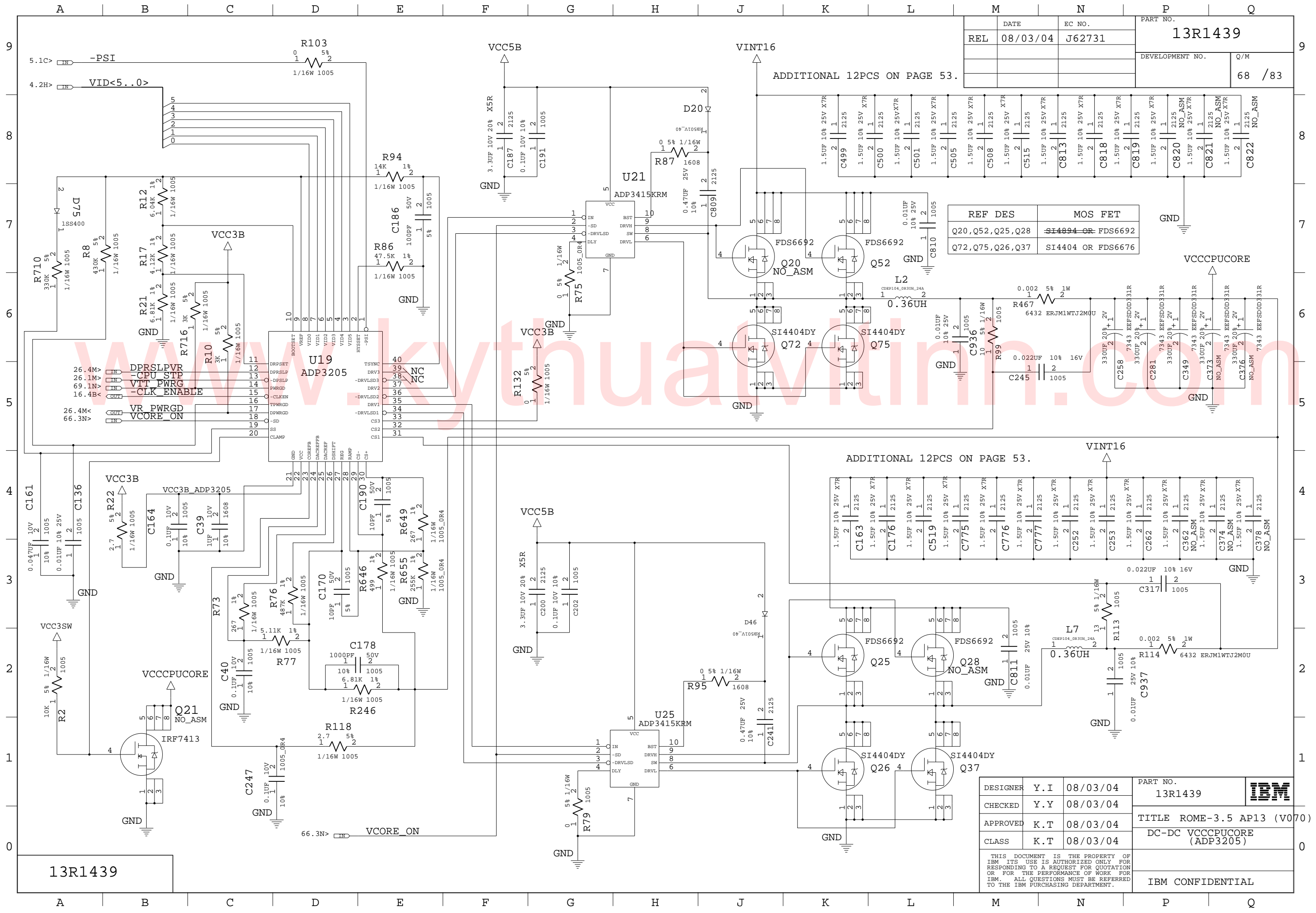

REL	DATE	EC NO.	PART NO.
	08/03/04	J62731	13R1439
			DEVELOPMENT NO.
			Q/M
			68 / 83

REF DES	MOS FET
Q20, Q52, Q25, Q28	SI4894 OR FDS6692
Q72, Q75, Q26, Q37	SI4404 OR FDS6676

DESIGNER	Y.I	08/03/04	PART NO.	13R1439	
CHECKED	Y.Y	08/03/04	TITLE		
APPROVED	K.T	08/03/04	DC-DC VCCCPUCORE (ADP3205)		
CLASS	K.T	08/03/04	IBM CONFIDENTIAL		

THIS DOCUMENT IS THE PROPERTY OF IBM. ITS USE IS AUTHORIZED ONLY FOR RESPONDING TO A REQUEST FOR QUOTATION OR FOR THE PERFORMANCE OF WORK FOR IBM. ALL QUESTIONS MUST BE REFERRED TO THE IBM PURCHASING DEPARTMENT.

13R1439

REL	DATE	EC NO.	PART NO.
	08/03/04	J62731	13R1439
			DEVELOPMENT NO.
			Q/M
			69 / 83

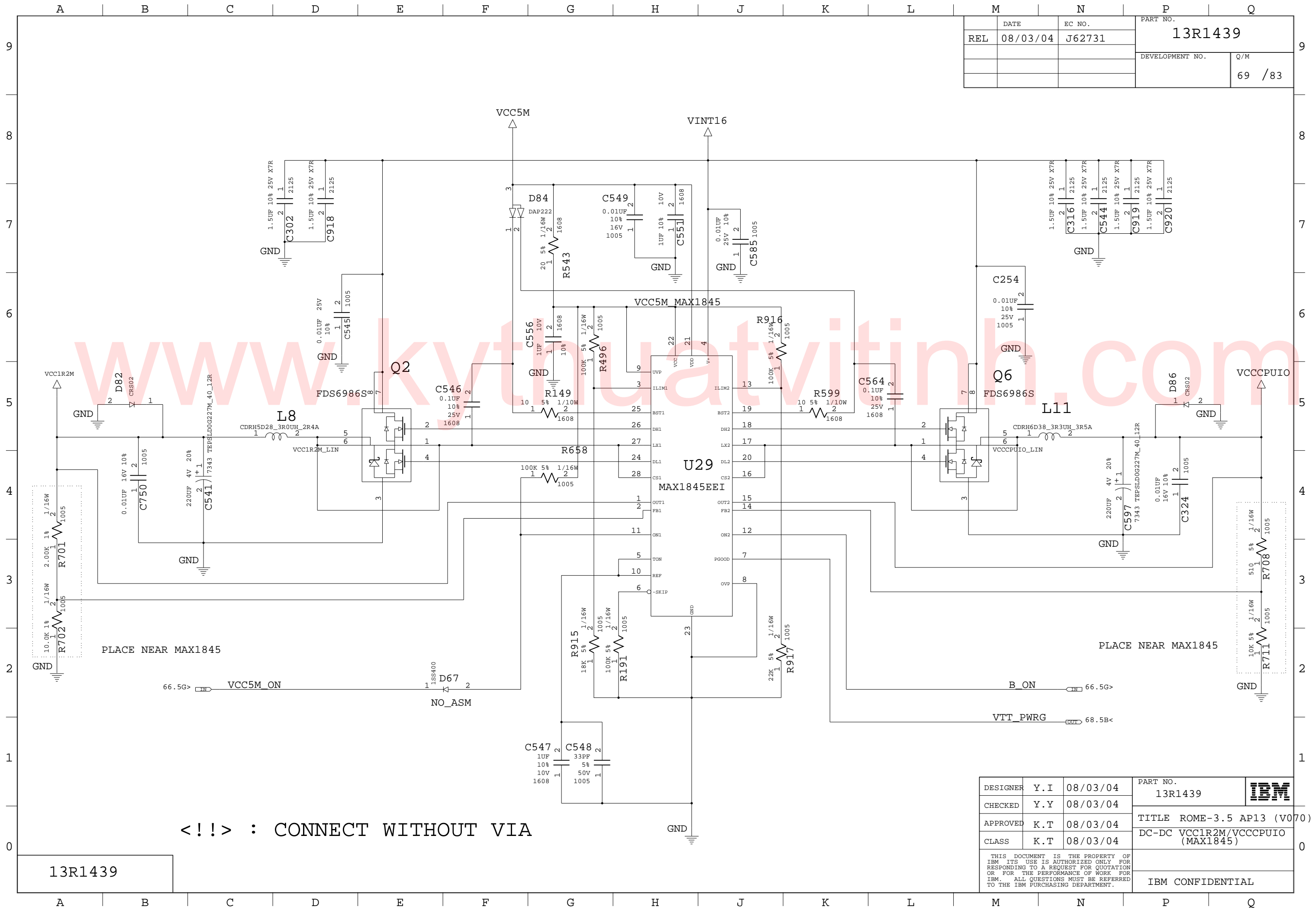

13R1439

<!!> : CONNECT WITHOUT VIA

DESIGNER	Y.I	08/03/04	PART NO.	13R1439	
CHECKED	Y.Y	08/03/04	TITLE		
APPROVED	K.T	08/03/04	DC-DC	VCC1R2M/VCCCPUIO (MAX1845)	
CLASS	K.T	08/03/04	IBM CONFIDENTIAL		

THIS DOCUMENT IS THE PROPERTY OF IBM. ITS USE IS AUTHORIZED ONLY FOR RESPONDING TO A REQUEST FOR QUOTATION OR FOR THE PERFORMANCE OF WORK FOR IBM. ALL QUESTIONS MUST BE REFERRED TO THE IBM PURCHASING DEPARTMENT.

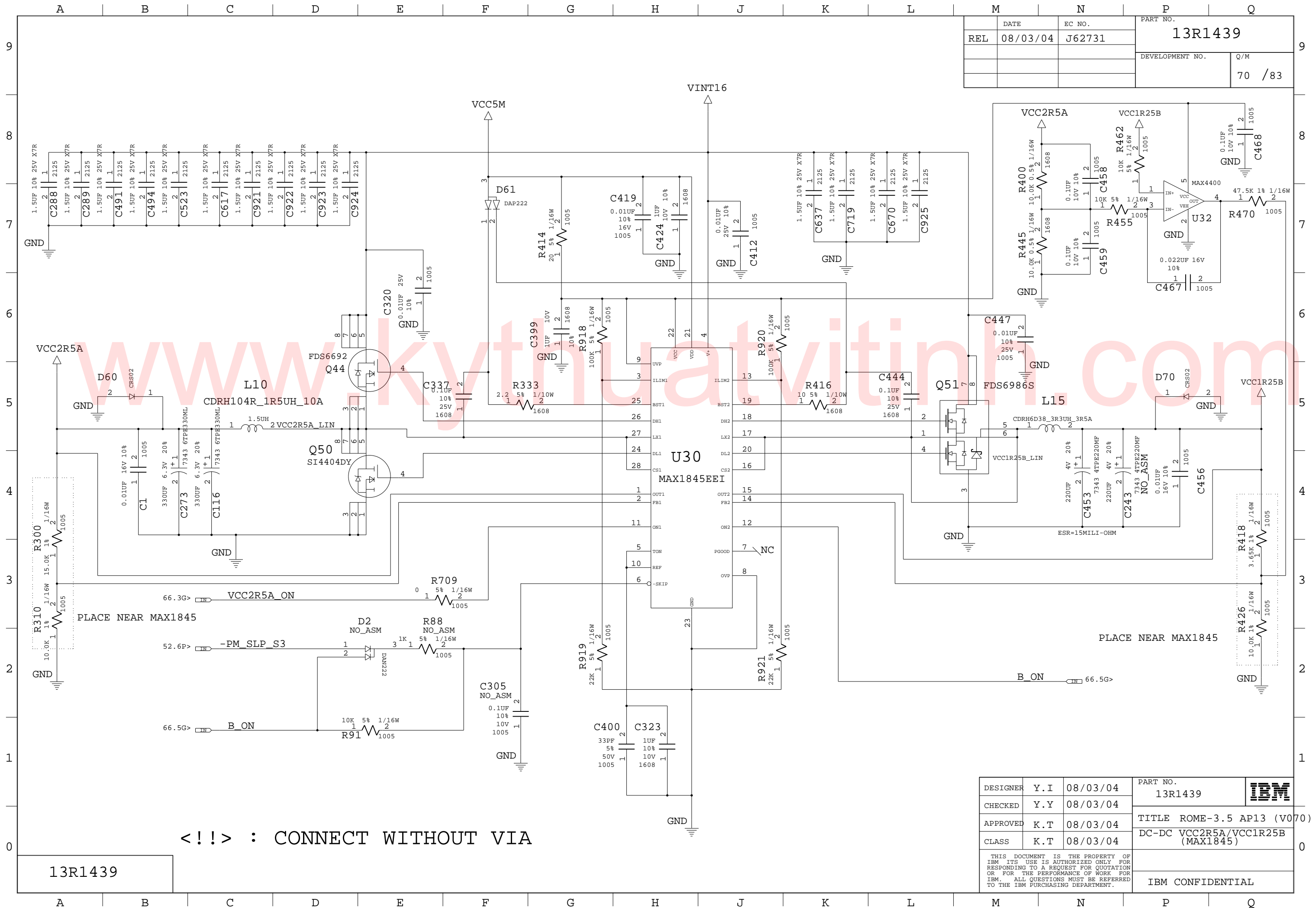

REL	DATE	EC NO.	PART NO.
	08/03/04	J62731	13R1439
			DEVELOPMENT NO.
			Q/M
			70 / 83

<!!> : CONNECT WITHOUT VIA

13R1439

DESIGNER	Y.I	08/03/04	PART NO.	13R1439	
CHECKED	Y.Y	08/03/04	TITLE		
APPROVED	K.T	08/03/04	CLASS	DC-DC VCC2R5A/VCC1R25B (MAX1845)	
					IBM CONFIDENTIAL

THIS DOCUMENT IS THE PROPERTY OF IBM. ITS USE IS AUTHORIZED ONLY FOR RESPONDING TO A REQUEST FOR QUOTATION OR FOR THE PERFORMANCE OF WORK FOR IBM. ALL QUESTIONS MUST BE REFERRED TO THE IBM PURCHASING DEPARTMENT.

DATE	EC NO.	PART NO.	
REL 08/03/04	J62731	13R1439	
		DEVELOPMENT NO.	Q/M
			71 /83

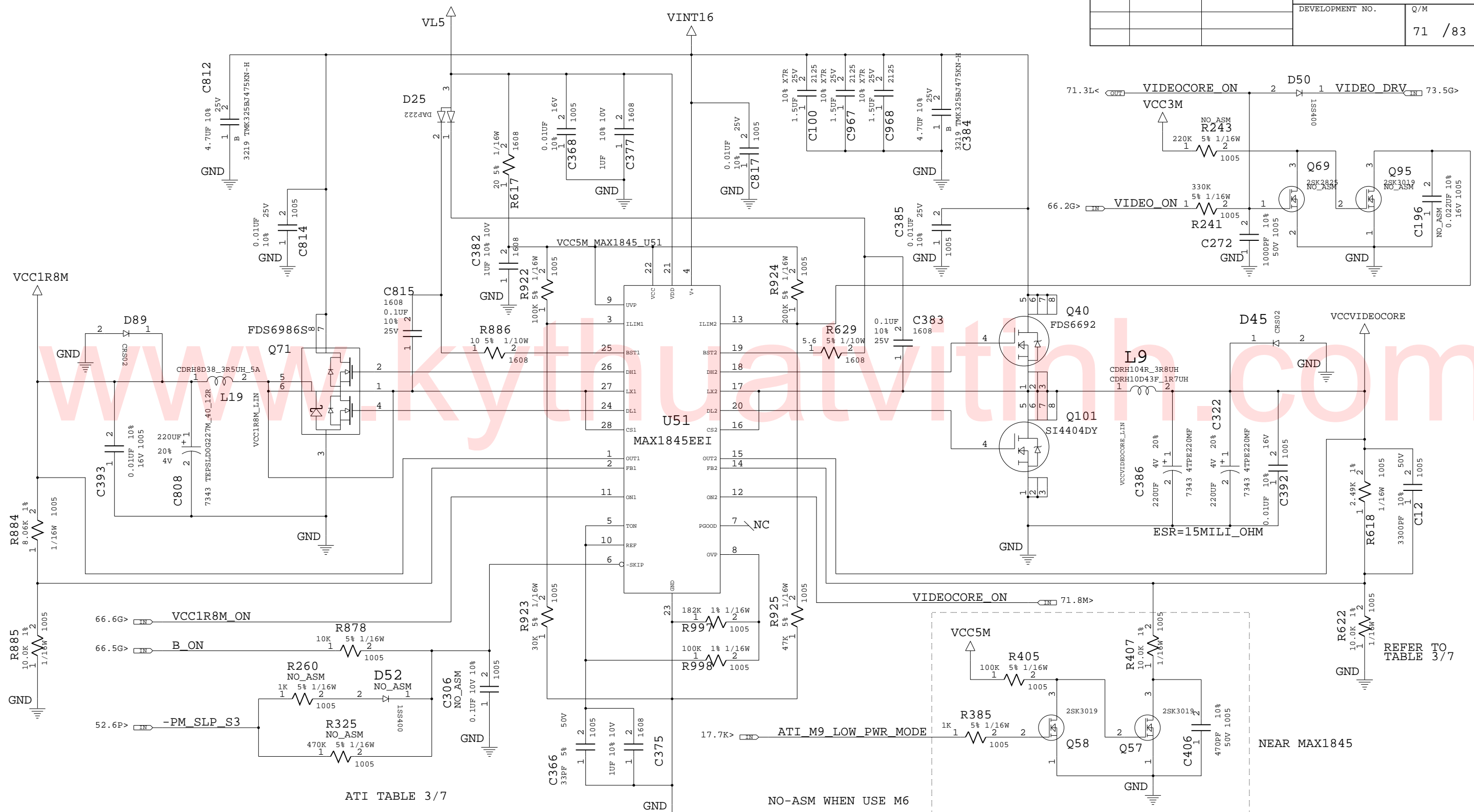

ATI TABLE 3/7

	M10	OTHERS
L9	CDRH10D43F_1R7UH	CDRH104R_3R8UH
C100	ASM	NO-ASM
C967	ASM	NO-ASM
C968	ASM	NO-ASM
C322	ASM	NO-ASM
R229	2.2	5.6
R925	47K	20K

	M6	M7	M9/M9+	M10
R405	NO-ASM	ASM	ASM	ASM
Q58	NO-ASM	ASM	ASM	ASM
R385	NO-ASM	ASM	ASM	ASM
R407	NO-ASM	ASM	ASM	ASM
Q57	NO-ASM	ASM	ASM	ASM
C406	NO-ASM	ASM	ASM	ASM
R618	8.06K	2.49K	2.49K	2.00K
R622	10.0K	10.0K	10.0K	NO-ASM

LOGIC

13R1439

DESIGNER	Y.I	08/03/04	PART NO.	13R1439	
CHECKED	Y.Y	08/03/04	TITLE		
APPROVED	K.T	08/03/04	CLASS	DC-DC VCC1R8M/ VCCVIDEOCORE (MAX1844)	
				IBM CONFIDENTIAL	

THIS DOCUMENT IS THE PROPERTY OF IBM. ITS USE IS AUTHORIZED ONLY FOR RESPONDING TO A REQUEST FOR QUOTATION OR FOR THE PERFORMANCE OF WORK FOR IBM. ALL QUESTIONS MUST BE REFERRED TO THE IBM PURCHASING DEPARTMENT.

	DATE	EC NO.	PART NO.	
REL	08/03/04	J62731	13R1439	
			DEVELOPMENT NO.	Q/M
				72 / 83

VINT16 VDD15

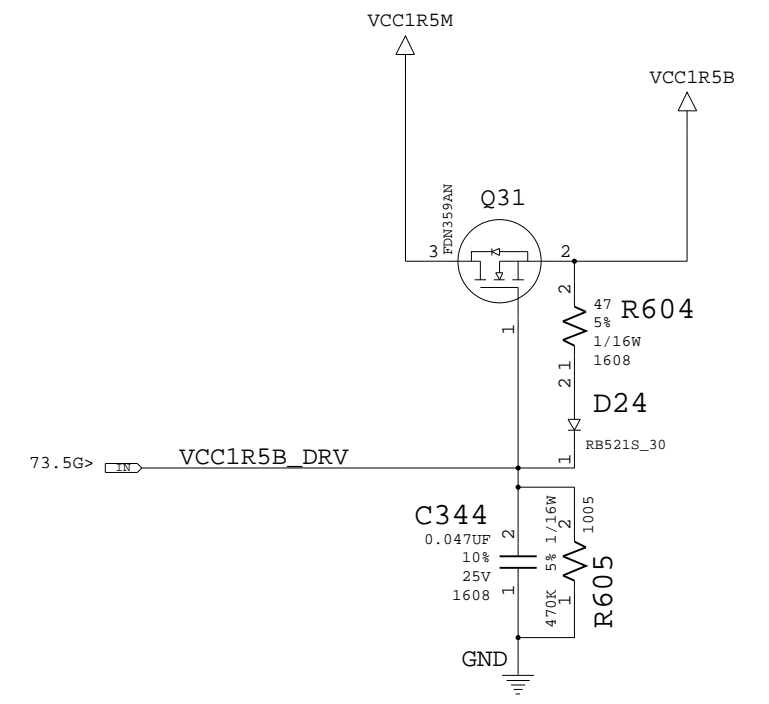
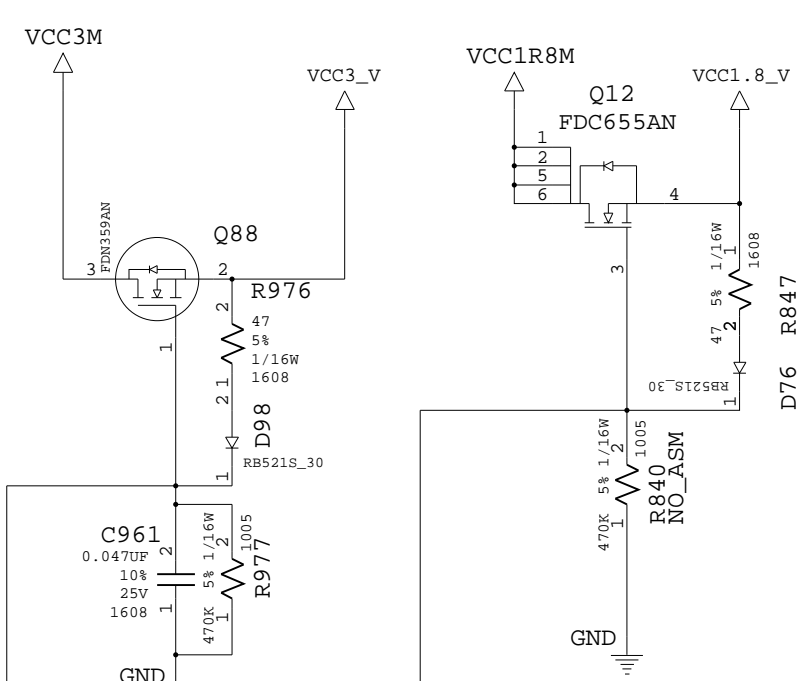
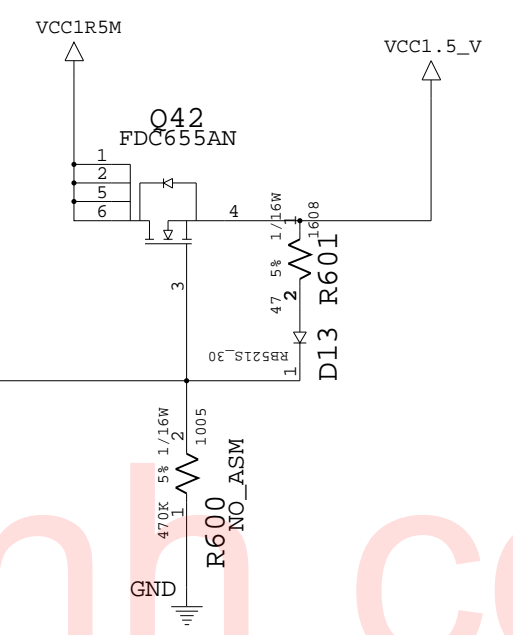
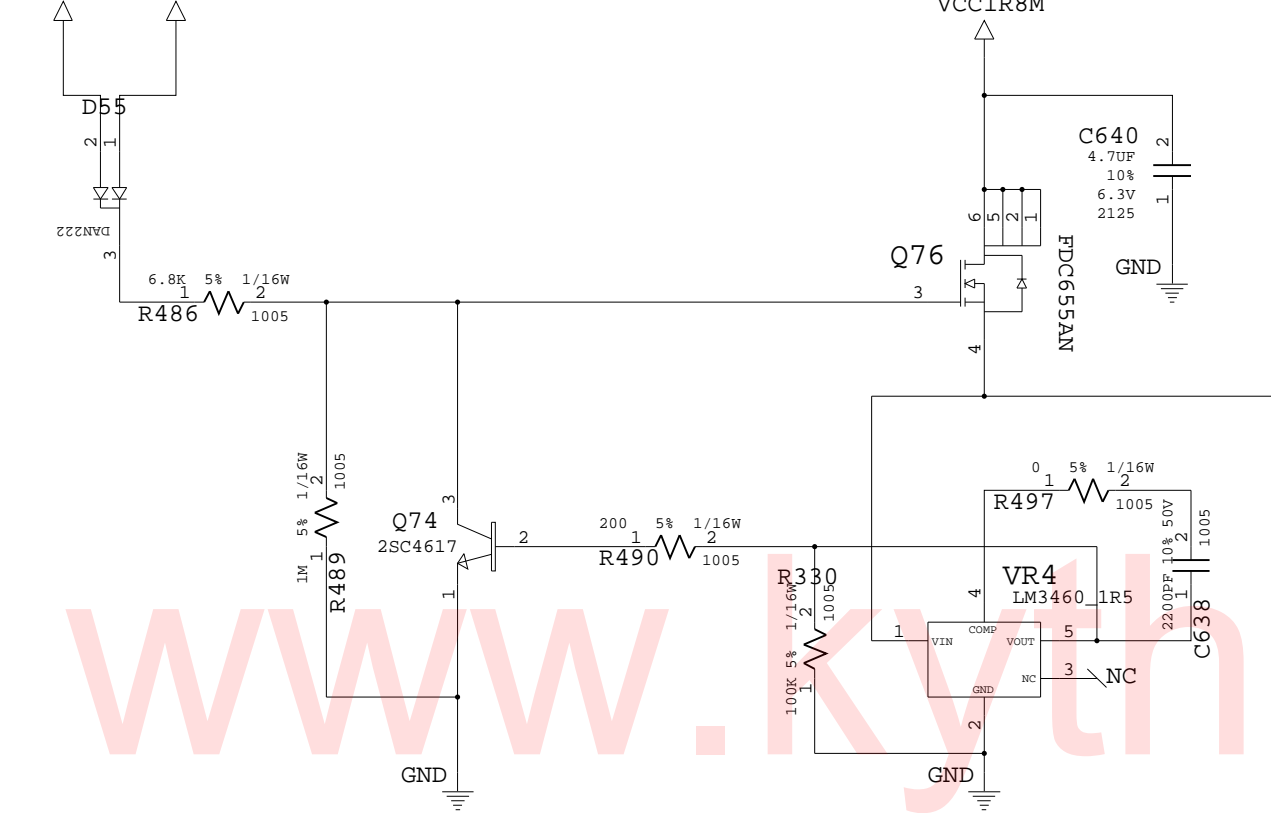

13R1439

DESIGNER	Y.I	08/03/04	PART NO.	13R1439	
CHECKED	Y.Y	08/03/04			
APPROVED	K.T	08/03/04	TITLE ROME-3.5 AP13 (V070)		
CLASS	K.T	08/03/04	VCC1R5M/A/B/AUX		
THIS DOCUMENT IS THE PROPERTY OF IBM. ITS USE IS AUTHORIZED ONLY FOR RESPONDING TO A REQUEST FOR QUOTATION OR FOR THE PERFORMANCE OF WORK FOR IBM. ALL QUESTIONS MUST BE REFERRED TO THE IBM PURCHASING DEPARTMENT.				IBM CONFIDENTIAL	





	DATE	EC NO.	PART NO.	
REL	08/03/04	J62731	13R1439	
			DEVELOPMENT NO.	Q/M
				74 /83

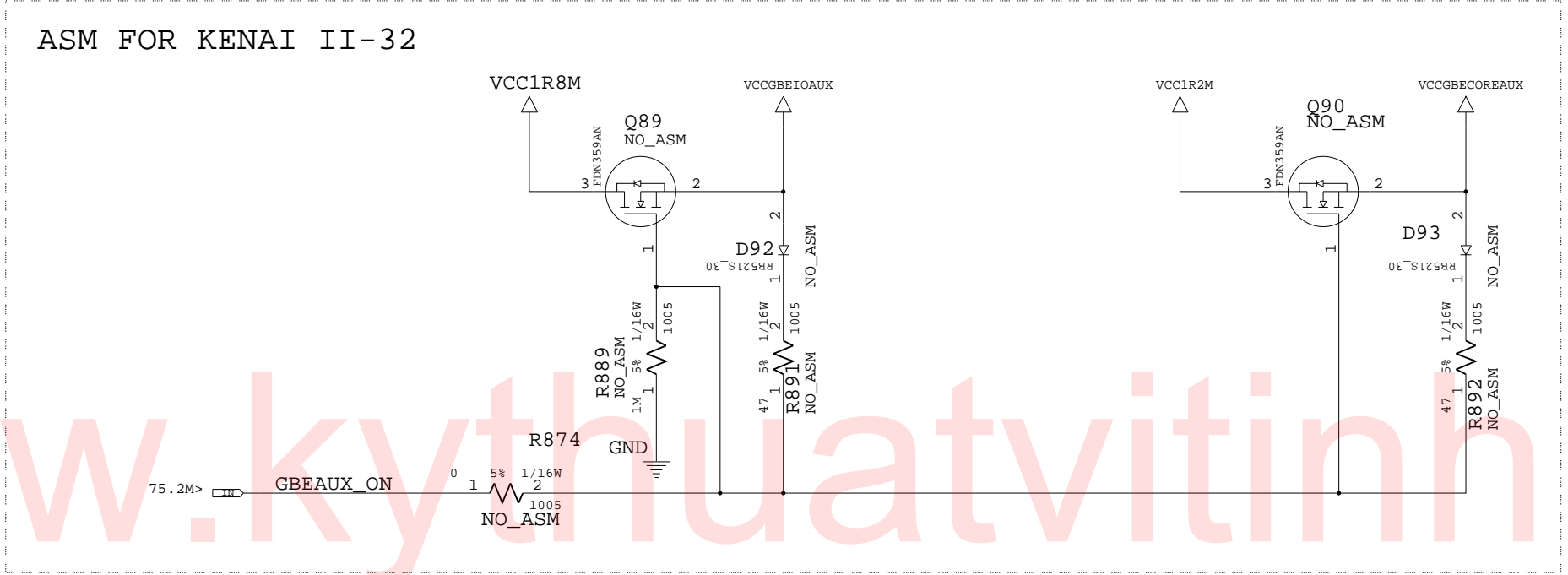

	KENAI32	KINNERETH-R	KENAI2-32
VCCGBECOREAUX	1.5V	3.3V	1.2V
VCCGBIOAUX	2.5V	N.C.	1.8V

ETHERNET TABLE (5/5)

		KENNERETH-R	KENAI2-32	KENAI32M
2.5V	U31	NO-ASM	NO-ASM	ASM
	C665	NO-ASM	NO-ASM	ASM
	C668	NO-ASM	NO-ASM	ASM
1.5V	R887	NO-ASM	NO-ASM	ASM
3.3V	R888	ASM	NO-ASM	NO-ASM
1.2V	Q89	NO-ASM	ASM	NO-ASM
	R874	NO-ASM	ASM	NO-ASM
	R889	NO-ASM	ASM	NO-ASM
	R891	NO-ASM	ASM	NO-ASM
	D92	NO-ASM	ASM	NO-ASM
1.8V	Q90	NO-ASM	ASM	NO-ASM
	R892	NO-ASM	ASM	NO-ASM
	D93	NO-ASM	ASM	NO-ASM

LOGIC

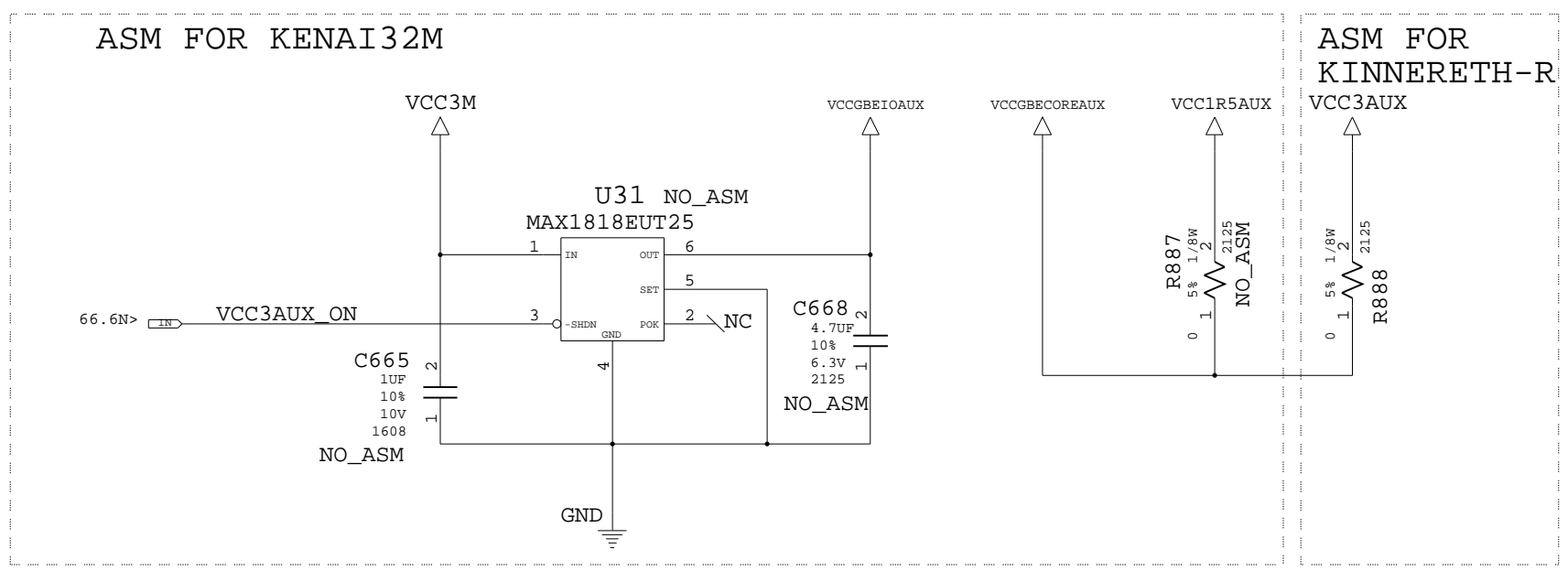

13R1439

DESIGNER	Y.I	08/03/04	PART NO.	13R1439	
CHECKED	Y.Y	08/03/04			
APPROVED	K.T	08/03/04	TITLE ROME-3.5 AP13 (V070)		
CLASS	K.T	08/03/04	DC-DC VCC2R5AUX, LOAD SW		
THIS DOCUMENT IS THE PROPERTY OF IBM. ITS USE IS AUTHORIZED ONLY FOR RESPONDING TO A REQUEST FOR QUOTATION OR FOR THE PERFORMANCE OF WORK FOR IBM. ALL QUESTIONS MUST BE REFERRED TO THE IBM PURCHASING DEPARTMENT.					IBM CONFIDENTIAL

A B C D E F G H J K L M N P Q

REL	DATE 08/03/04	EC NO. J62731	PART NO. 13R1439
			DEVELOPMENT NO. 75 /83

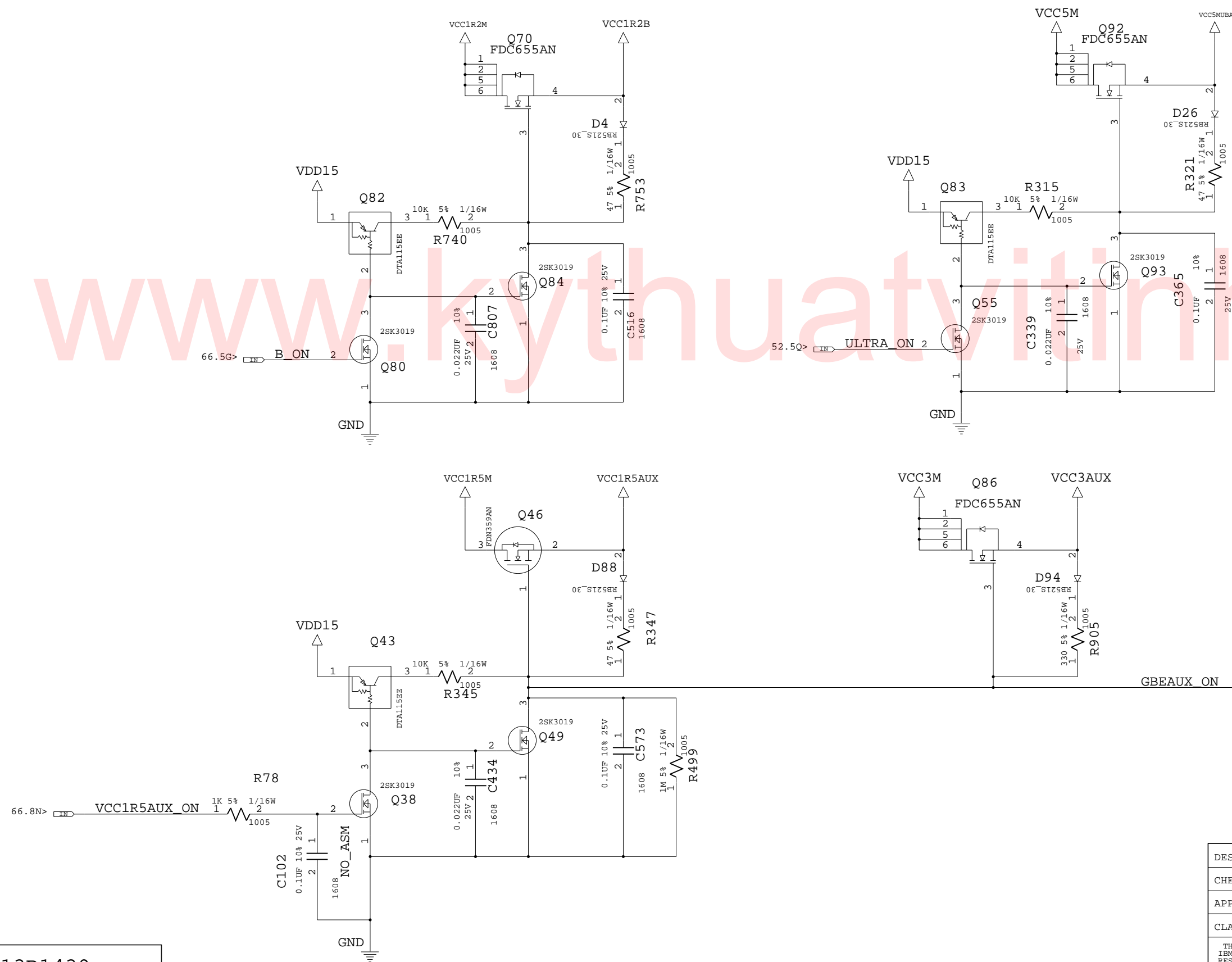

13R1439

DESIGNER	Y.I	08/03/04	PART NO. 13R1439	
CHECKED	Y.Y	08/03/04	TITLE ROME-3.5 AP13 (V070)	
APPROVED	K.T	08/03/04	DC-DC LOAD SW	
CLASS	K.T	08/03/04		
THIS DOCUMENT IS THE PROPERTY OF IBM. ITS USE IS AUTHORIZED ONLY FOR RESPONDING TO A REQUEST FOR QUOTATION OR FOR THE PERFORMANCE OF WORK FOR IBM. ALL QUESTIONS MUST BE REFERRED TO THE IBM PURCHASING DEPARTMENT.				IBM CONFIDENTIAL

A B C D E F G H J K L M N P Q

DATE	EC NO.	PART NO.
REL 08/03/04	J62731	13R1439
		DEVELOPMENT NO.
		Q/M
		76 /83

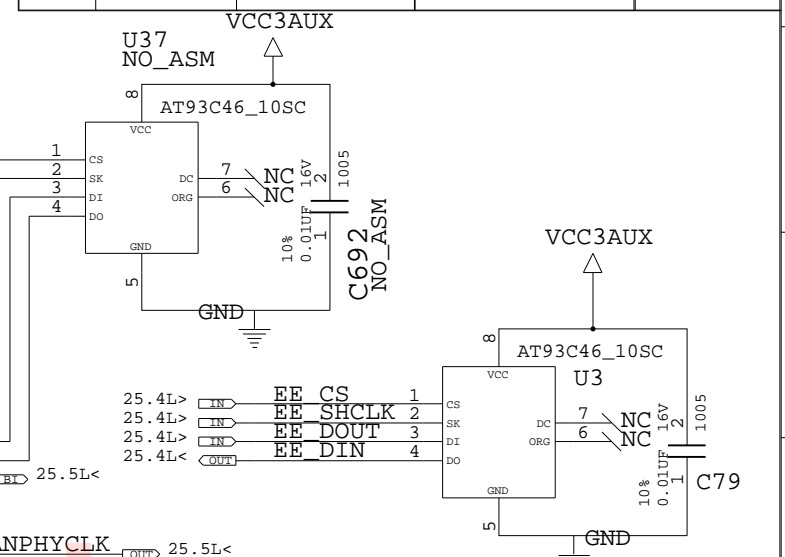
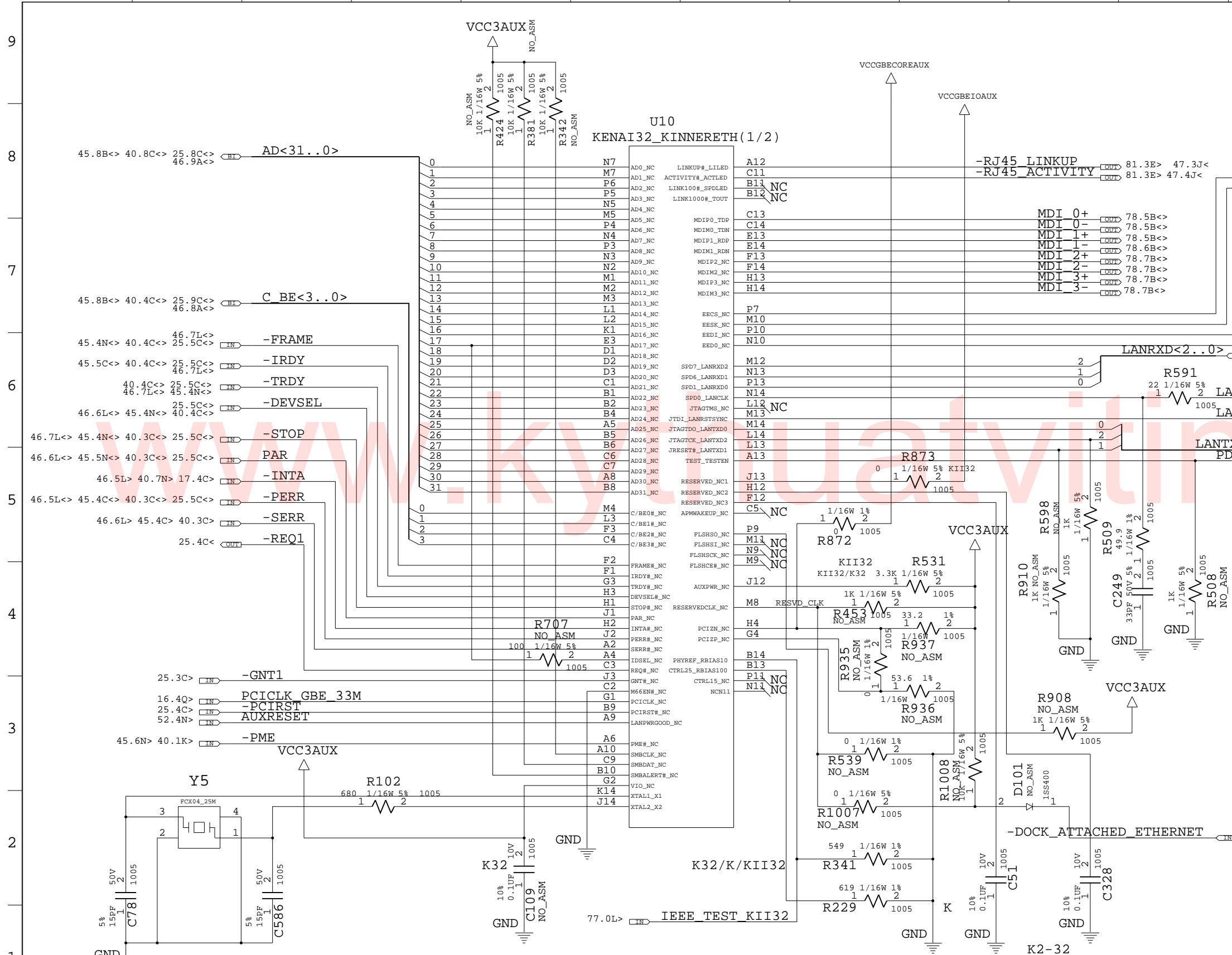

THIS EEPROM SHOULD BE CLOSE TO ICH4.

ETHERNET TABLE (2/5)  
LOGIC

	KENNERETH-R	KENAI II32	KENAI32M
R424	NO-ASM	ASM	ASM
R381	NO-ASM	ASM	ASM
R342	NO-ASM	ASM	ASM
R707	NO-ASM	ASM	ASM
C109	NO-ASM	ASM	ASM
R591	ASM	NO-ASM	NO-ASM
R509	ASM	NO-ASM	NO-ASM
C249	ASM	NO-ASM	NO-ASM
R508	NO-ASM	ASM	ASM
R531	NO-ASM	ASM	ASM
R539	NO-ASM	NO-ASM	NO-ASM
R341	549 1%	NO-ASM	2.49K 1%
R229	ASM	NO-ASM	NO-ASM
R872	NO-ASM	ASM	NO-ASM
R873	NO-ASM	ASM	NO-ASM
R908	NO-ASM	ASM	NO-ASM
R910	NO-ASM	ASM	ASM
U37	NO-ASM	ASM	ASM
C692	NO-ASM	ASM	ASM
U3	ASM	NO-ASM	NO-ASM
C79	ASM	NO-ASM	NO-ASM
R598	NO-ASM	ASM	ASM
R102	680 5%	0 5%	0 5%
C78	15PF 5%	10PF 5%	10PF 5%
C586	15PF 5%	10PF 5%	10PF 5%
R937	NO-ASM	NO-ASM	ASM
R936	NO-ASM	NO-ASM	ASM
R935	NO-ASM	ASM	NO-ASM
C51	NO-ASM	ASM	NO-ASM
C328	NO-ASM	ASM	NO-ASM
R453	NO-ASM	NO-ASM	NO-ASM
R1007	NO-ASM	ASM	NO-ASM
R1008	NO-ASM	ASM	NO-ASM
D101	NO-ASM	ASM	NO-ASM

KII32:INSTALL COMPONENT IF USING KENAI II 32 MAC/PHY  
 K32:INSTALL COMPONENT IF USING KENAI32 MAC/PHY  
 K:INSTALL COMPONENT IF USING KINNERRETHPHY  
 FOR R341 : INSTALL 549 OHM RESISTOR (1%) WITH KINNERETH CONTROLLER OR 2.49K OHM RESISTOR (1%) WITH KENAI32 CONTROLLER BUT NO RESISTER WITH KENAI II 32.

DESIGNER	Y.I	08/03/04	PART NO.	13R1439	
CHECKED	Y.Y	08/03/04			
APPROVED	K.T	08/03/04	TITLE ROME-3.5 AP13 (V070)		
CLASS	K.T	08/03/04	GIGABIT ETHERNET (1/3)		
THIS DOCUMENT IS THE PROPERTY OF IBM ITS USE IS AUTHORIZED ONLY FOR RESPONDING TO A REQUEST FOR QUOTATION OR FOR THE PERFORMANCE OF WORK FOR IBM. ALL QUESTIONS MUST BE REFERRED TO THE IBM PURCHASING DEPARTMENT.					IBM CONFIDENTIAL

DATE	EC NO.	PART NO.	
REL 08/03/04	J62731	13R1439	
		DEVELOPMENT NO.	Q/M
			77 /83

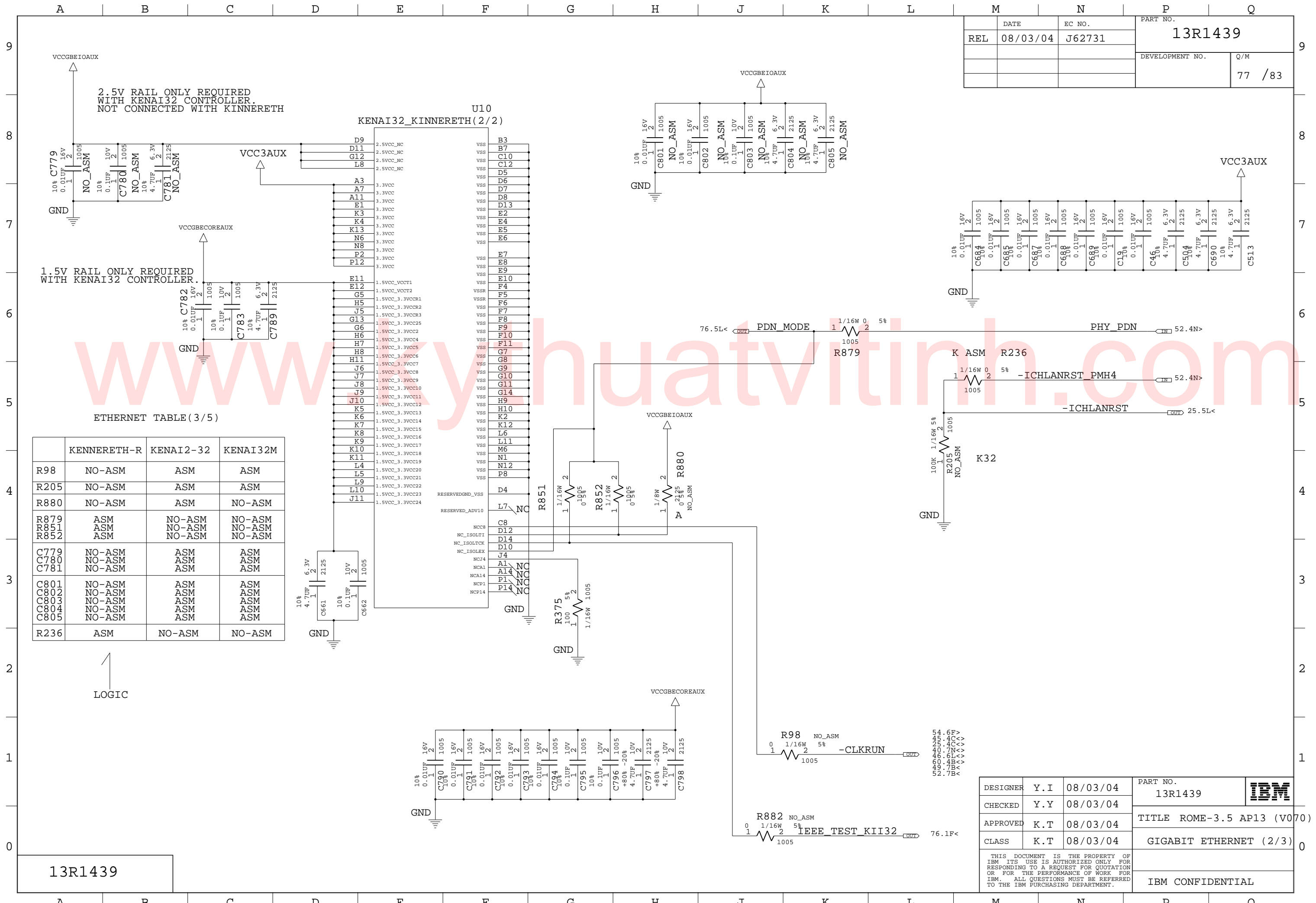

2.5V RAIL ONLY REQUIRED WITH KENAI32 CONTROLLER. NOT CONNECTED WITH KINNERETH

1.5V RAIL ONLY REQUIRED WITH KENAI32 CONTROLLER.

ETHERNET TABLE (3/5)

	KENNERETH-R	KENAI2-32	KENAI32M
R98	NO-ASM	ASM	ASM
R205	NO-ASM	ASM	ASM
R880	NO-ASM	ASM	NO-ASM
R879	ASM	NO-ASM	NO-ASM
R851	ASM	NO-ASM	NO-ASM
R852	ASM	NO-ASM	NO-ASM
C779	NO-ASM	ASM	ASM
C780	NO-ASM	ASM	ASM
C781	NO-ASM	ASM	ASM
C801	NO-ASM	ASM	ASM
C802	NO-ASM	ASM	ASM
C803	NO-ASM	ASM	ASM
C804	NO-ASM	ASM	ASM
C805	NO-ASM	ASM	ASM
R236	ASM	NO-ASM	NO-ASM

LOGIC

13R1439

DESIGNER	Y.I	08/03/04	PART NO.	13R1439	
CHECKED	Y.Y	08/03/04	TITLE		
APPROVED	K.T	08/03/04	CLASS	GIGABIT ETHERNET (2/3)	
THIS DOCUMENT IS THE PROPERTY OF IBM. ITS USE IS AUTHORIZED ONLY FOR RESPONDING TO A REQUEST FOR QUOTATION OR FOR THE PERFORMANCE OF WORK FOR IBM. ALL QUESTIONS MUST BE REFERRED TO THE IBM PURCHASING DEPARTMENT.					IBM CONFIDENTIAL

DATE	EC NO.	PART NO.	
REL 08/03/04	J62731	13R1439	
		DEVELOPMENT NO.	Q/M
			78 / 83

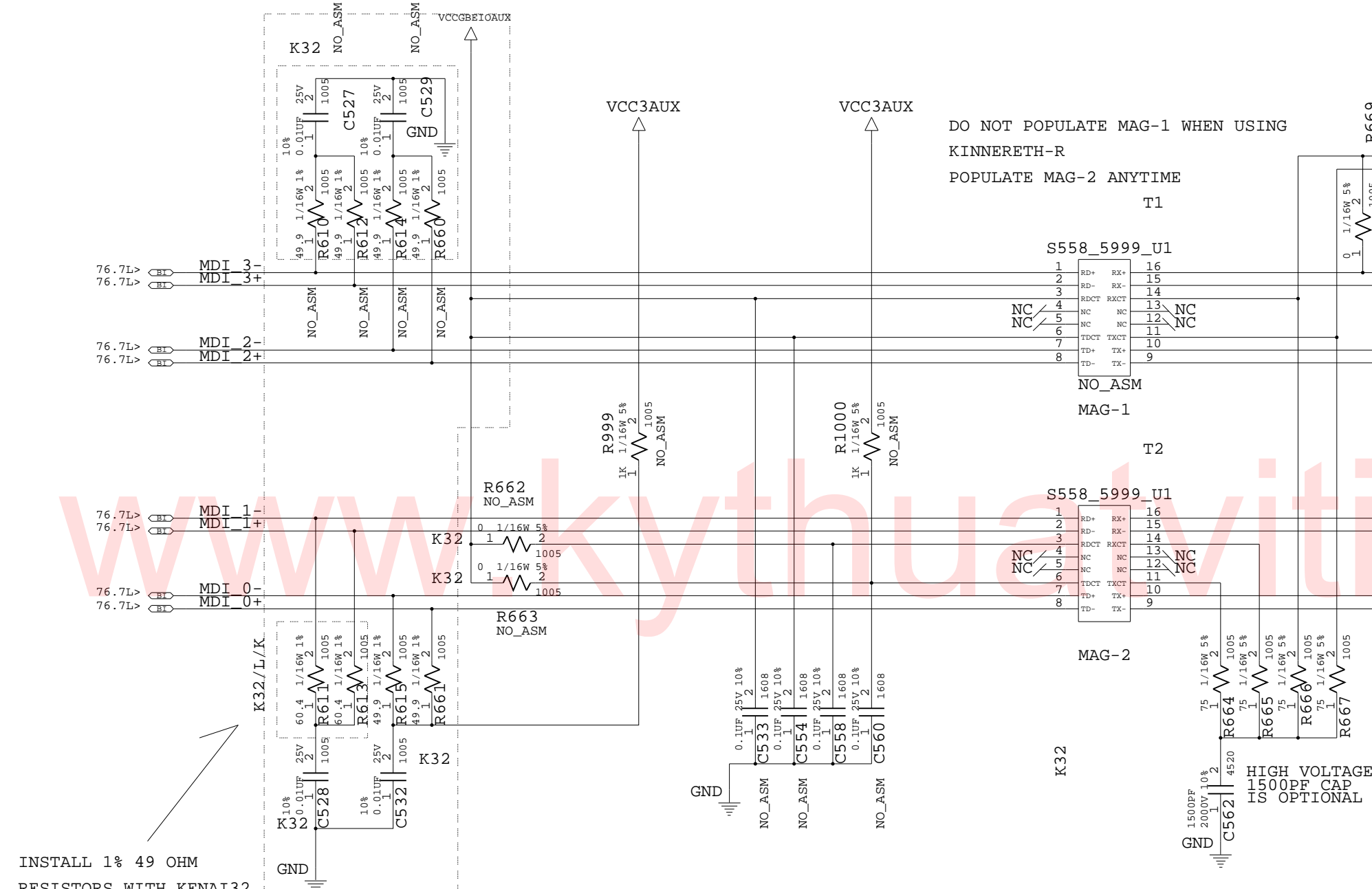

DO NOT POPULATE MAG-1 WHEN USING KINNERETH-R  
POPULATE MAG-2 ANYTIME

THESE FOUR RESISTORS ARE POPULATED FOR KINNERETH-R

INSTALL 1% 49 OHM RESISTORS WITH KENAI32 AND WITH KENAI II 32, OR 1% 60.4 OHM RESISTORS WITH LAVON AND KINNERETH-R CONTROLLERS.

THESE R AND C SHOULD BE PLACED NEAR PHY CHIP (KENAI32M, KENAI2-32 AND KINNERETH-R)

T1 : S558-599-BD FOR KENAI32M OR KENAI2-32  
T2 : S558-599-BD FOR KENAI32M OR KENAI2-32, S558-599-U1 FOR KINNERETH-R

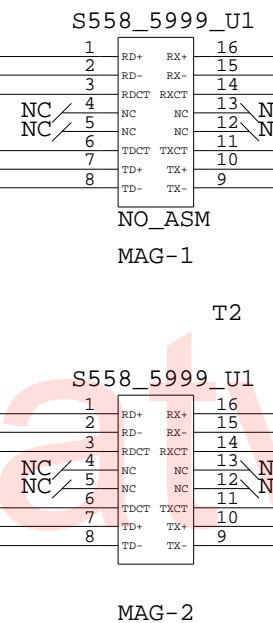

ETHERNET TABLE (4/5)

	KENNERETH-R	KENAI II-32	KENAI32M
C527	NO-ASM	ASM	ASM
C529	NO-ASM	ASM	ASM
R610	NO-ASM	ASM	ASM
R612	NO-ASM	ASM	ASM
R614	NO-ASM	ASM	ASM
R660	NO-ASM	ASM	ASM
C528	NO-ASM	ASM	ASM
C532	NO-ASM	ASM	ASM
R611	60.4	49.9	49.9
R613	60.4	49.9	49.9
C533	NO-ASM	ASM	ASM
C554	NO-ASM	ASM	ASM
C560	NO-ASM	ASM	ASM
R662	NO-ASM	ASM	ASM
R663	NO-ASM	ASM	ASM
R669	ASM	NO-ASM	NO-ASM
R670	ASM	NO-ASM	NO-ASM
R671	ASM	NO-ASM	NO-ASM
R703	ASM	NO-ASM	NO-ASM
T1	NO-ASM	ASM	ASM
T2	ASM	ASM	ASM

HIGH VOLTAGE 1500PF CAP IS OPTIONAL

LOGIC

DESIGNER	Y.I	08/03/04	PART NO.	13R1439	
CHECKED	Y.Y	08/03/04			
APPROVED	K.T	08/03/04	TITLE ROME-3.5 AP13 (V070)		
CLASS	K.T	08/03/04	GIGABIT ETHERNET (3/3)		
THIS DOCUMENT IS THE PROPERTY OF IBM. ITS USE IS AUTHORIZED ONLY FOR RESPONDING TO A REQUEST FOR QUOTATION OR FOR THE PERFORMANCE OF WORK FOR IBM. ALL QUESTIONS MUST BE REFERRED TO THE IBM PURCHASING DEPARTMENT.					IBM CONFIDENTIAL

13R1439

A B C D E F G H J K L M N P Q

REL	DATE 08/03/04	EC NO. J62731	PART NO. 13R1439	
			DEVELOPMENT NO.	Q/M 79 /83

LARGE PTH HOLE

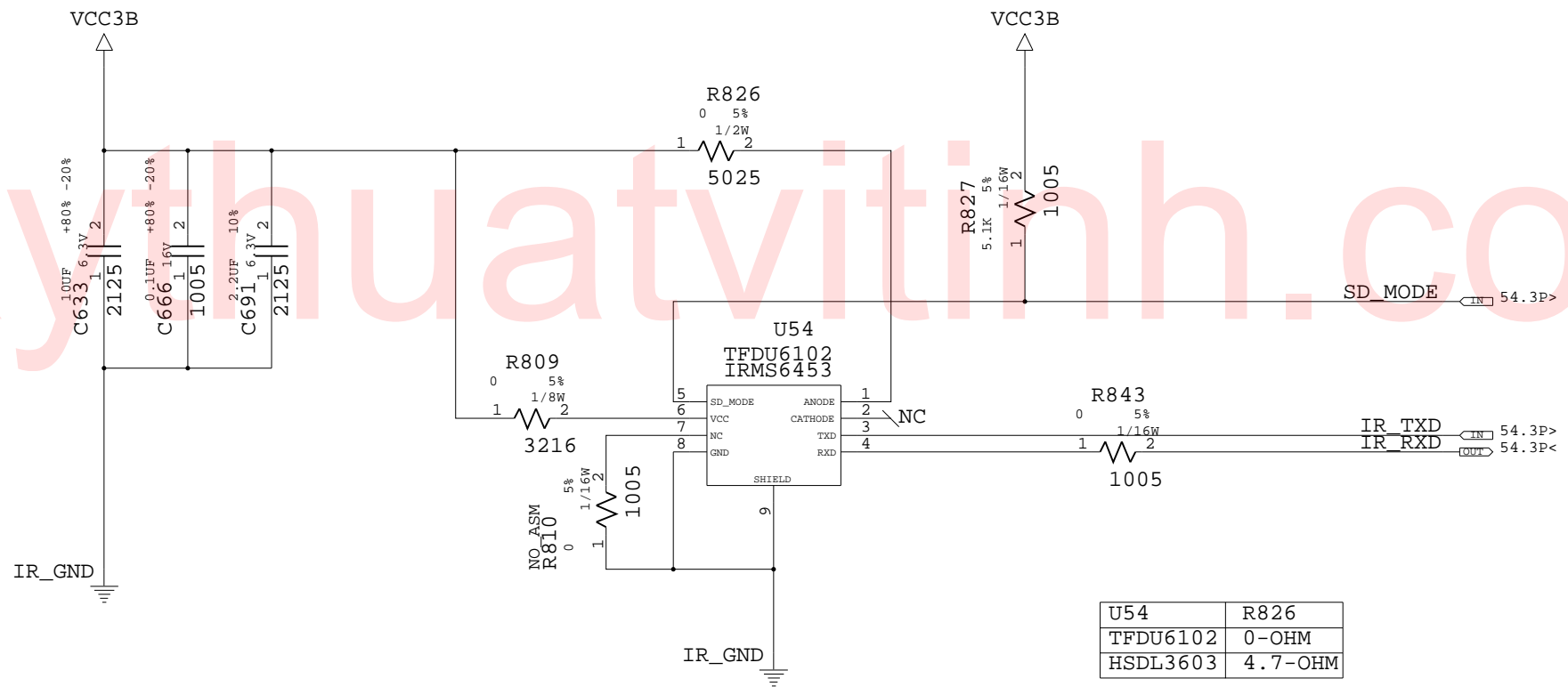
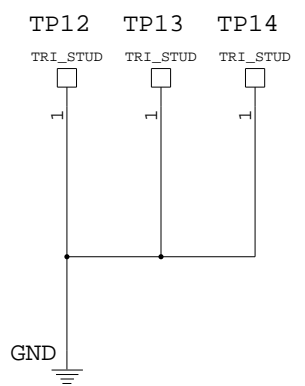

U54	R826
TFDU6102	0-OHM
HSDL3603	4.7-OHM

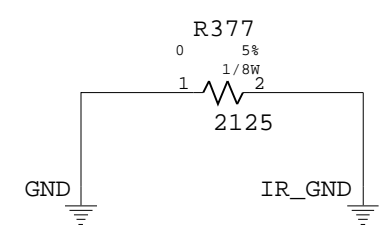

13R1439

DESIGNER	Y.I	08/03/04	PART NO.	13R1439	
CHECKED	Y.Y	08/03/04	TITLE		
APPROVED	K.T	08/03/04	CLASS	IR MODULE	
THIS DOCUMENT IS THE PROPERTY OF IBM. ITS USE IS AUTHORIZED ONLY FOR RESPONDING TO A REQUEST FOR QUOTATION OR FOR THE PERFORMANCE OF WORK FOR IBM. ALL QUESTIONS MUST BE REFERRED TO THE IBM PURCHASING DEPARTMENT.					IBM CONFIDENTIAL

A B C D E F G H J K L M N P Q

	DATE	EC NO.	PART NO.	
REL	08/03/04	J62731	13R1439	
			DEVELOPMENT NO.	Q/M
				80 / 83

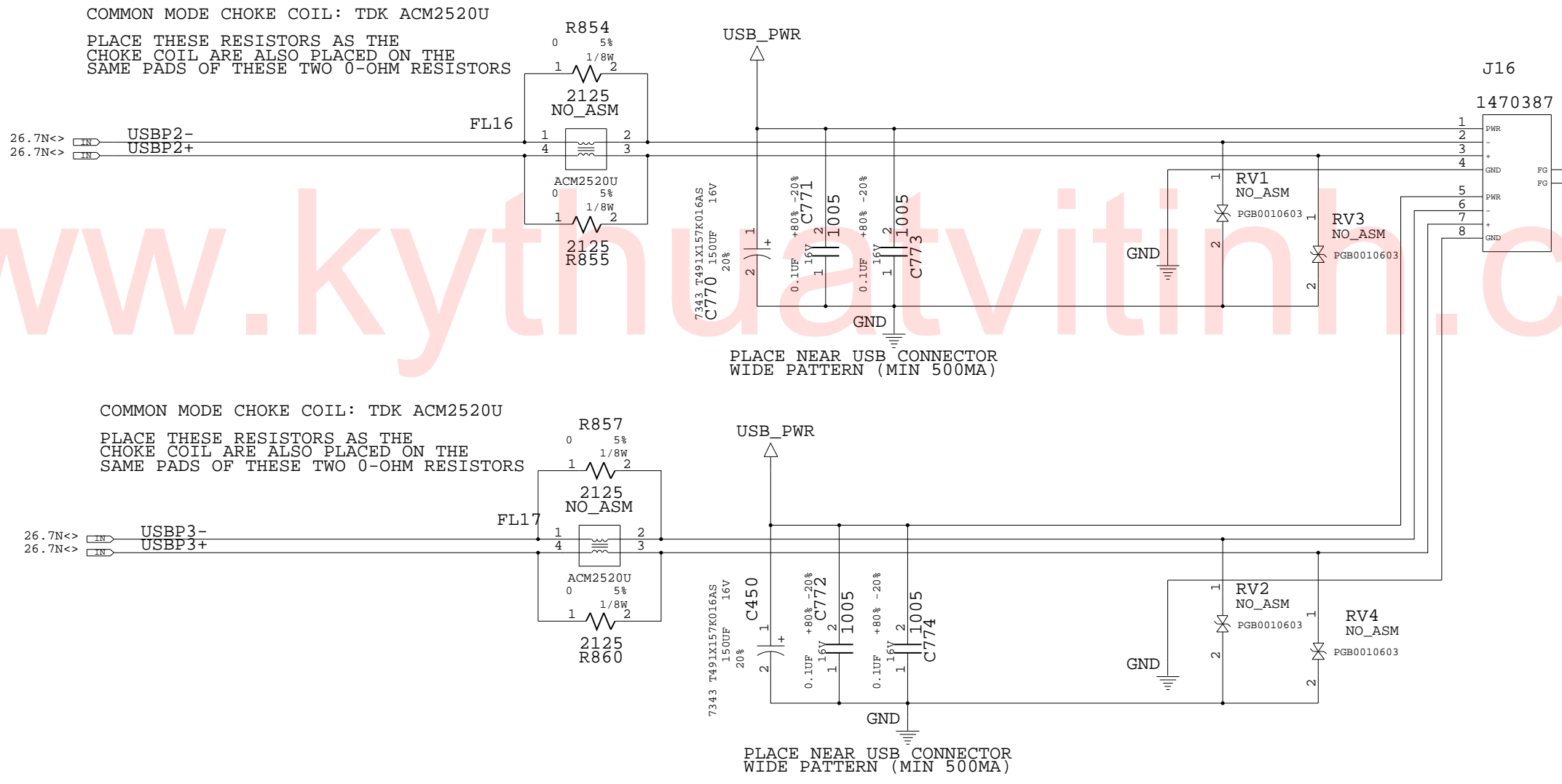

13R1439

DESIGNER	Y.I	08/03/04	PART NO.	13R1439	
CHECKED	Y.Y	08/03/04			
APPROVED	K.T	08/03/04	TITLE ROME-3.5 AP13 (V070)		
CLASS	K.T	08/03/04	USB CONNECTOR		
THIS DOCUMENT IS THE PROPERTY OF IBM. ITS USE IS AUTHORIZED ONLY FOR RESPONDING TO A REQUEST FOR QUOTATION OR FOR THE PERFORMANCE OF WORK FOR IBM. ALL QUESTIONS MUST BE REFERRED TO THE IBM PURCHASING DEPARTMENT.				IBM CONFIDENTIAL	



A B C D E F G H J K L M N P Q

REL	DATE 08/03/04	EC NO. J62731	PART NO. 13R1439
			DEVELOPMENT NO. Q/M 81 /83

	KINNERETH-R	KENAI2-32	KENAI32M
D104	NO-ASM	ASM	ASM

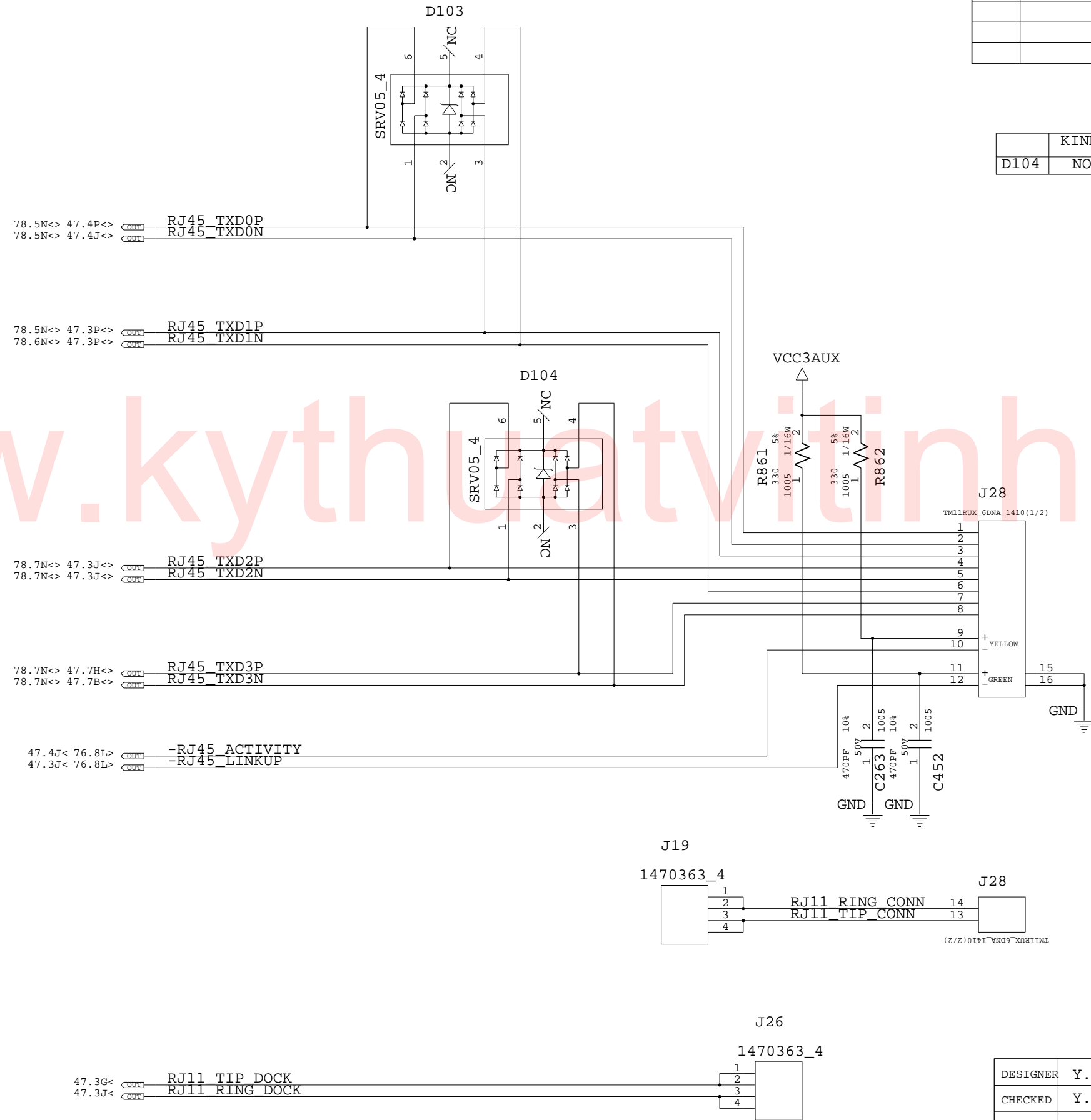

13R1439

DESIGNER	Y.I	08/03/04	PART NO. 13R1439	
CHECKED	Y.Y	08/03/04	TITLE ROME-3.5 AP13 (V070)	
APPROVED	K.T	08/03/04	CLASS	RJ-45/11 CONNECTOR
THIS DOCUMENT IS THE PROPERTY OF IBM. ITS USE IS AUTHORIZED ONLY FOR RESPONDING TO A REQUEST FOR QUOTATION OR FOR THE PERFORMANCE OF WORK FOR IBM. ALL QUESTIONS MUST BE REFERRED TO THE IBM PURCHASING DEPARTMENT.				IBM CONFIDENTIAL

A B C D E F G H J K L M N P Q

DATE	EC NO.	PART NO.	
REL 08/03/04	J62731	13R1439	
		DEVELOPMENT NO.	Q/M
			82 / 83

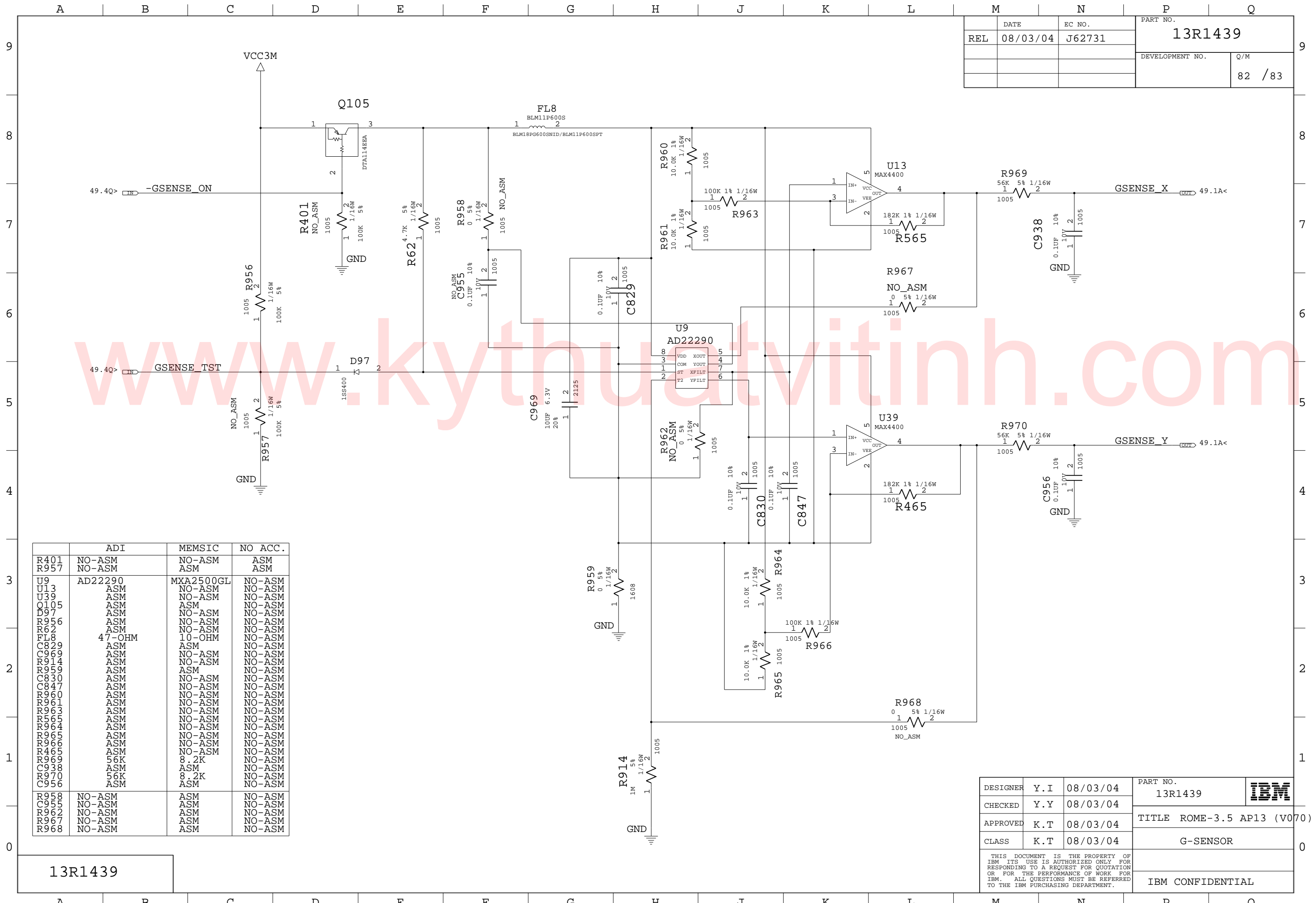

	ADI	MEMSIC	NO ACC.
R401	NO-ASM	NO-ASM	ASM
R957	NO-ASM	ASM	ASM
U9	AD22290	MXA2500GL	NO-ASM
U13	ASM	NO-ASM	NO-ASM
U39	ASM	NO-ASM	NO-ASM
Q105	ASM	NO-ASM	NO-ASM
D97	ASM	NO-ASM	NO-ASM
R956	ASM	NO-ASM	NO-ASM
R62	ASM	NO-ASM	NO-ASM
FL8	47-OHM	10-OHM	NO-ASM
C829	ASM	ASM	NO-ASM
C969	ASM	NO-ASM	NO-ASM
R914	ASM	NO-ASM	NO-ASM
R959	ASM	NO-ASM	NO-ASM
C830	ASM	NO-ASM	NO-ASM
C847	ASM	NO-ASM	NO-ASM
R960	ASM	NO-ASM	NO-ASM
R961	ASM	NO-ASM	NO-ASM
R963	ASM	NO-ASM	NO-ASM
R955	ASM	NO-ASM	NO-ASM
R964	ASM	NO-ASM	NO-ASM
R965	ASM	NO-ASM	NO-ASM
R966	ASM	NO-ASM	NO-ASM
R968	ASM	NO-ASM	NO-ASM
R969	56K	8.2K	NO-ASM
C938	ASM	ASM	NO-ASM
R970	56K	8.2K	NO-ASM
C956	ASM	ASM	NO-ASM
R958	NO-ASM	ASM	NO-ASM
C955	NO-ASM	ASM	NO-ASM
R962	NO-ASM	ASM	NO-ASM
R967	NO-ASM	ASM	NO-ASM
R968	NO-ASM	ASM	NO-ASM

13R1439

DESIGNER	Y.I	08/03/04	PART NO.	13R1439	IBM
CHECKED	Y.Y	08/03/04			
APPROVED	K.T	08/03/04	TITLE ROME-3.5 AP13 (V070)		
CLASS	K.T	08/03/04	G-SENSOR		
THIS DOCUMENT IS THE PROPERTY OF IBM. ITS USE IS AUTHORIZED ONLY FOR RESPONDING TO A REQUEST FOR QUOTATION OR FOR THE PERFORMANCE OF WORK FOR IBM. ALL QUESTIONS MUST BE REFERRED TO THE IBM PURCHASING DEPARTMENT.					IBM CONFIDENTIAL

	DATE	EC NO.	PART NO.	
REL	08/03/04	J62731	13R1439	
			DEVELOPMENT NO.	Q/M
				83 /83

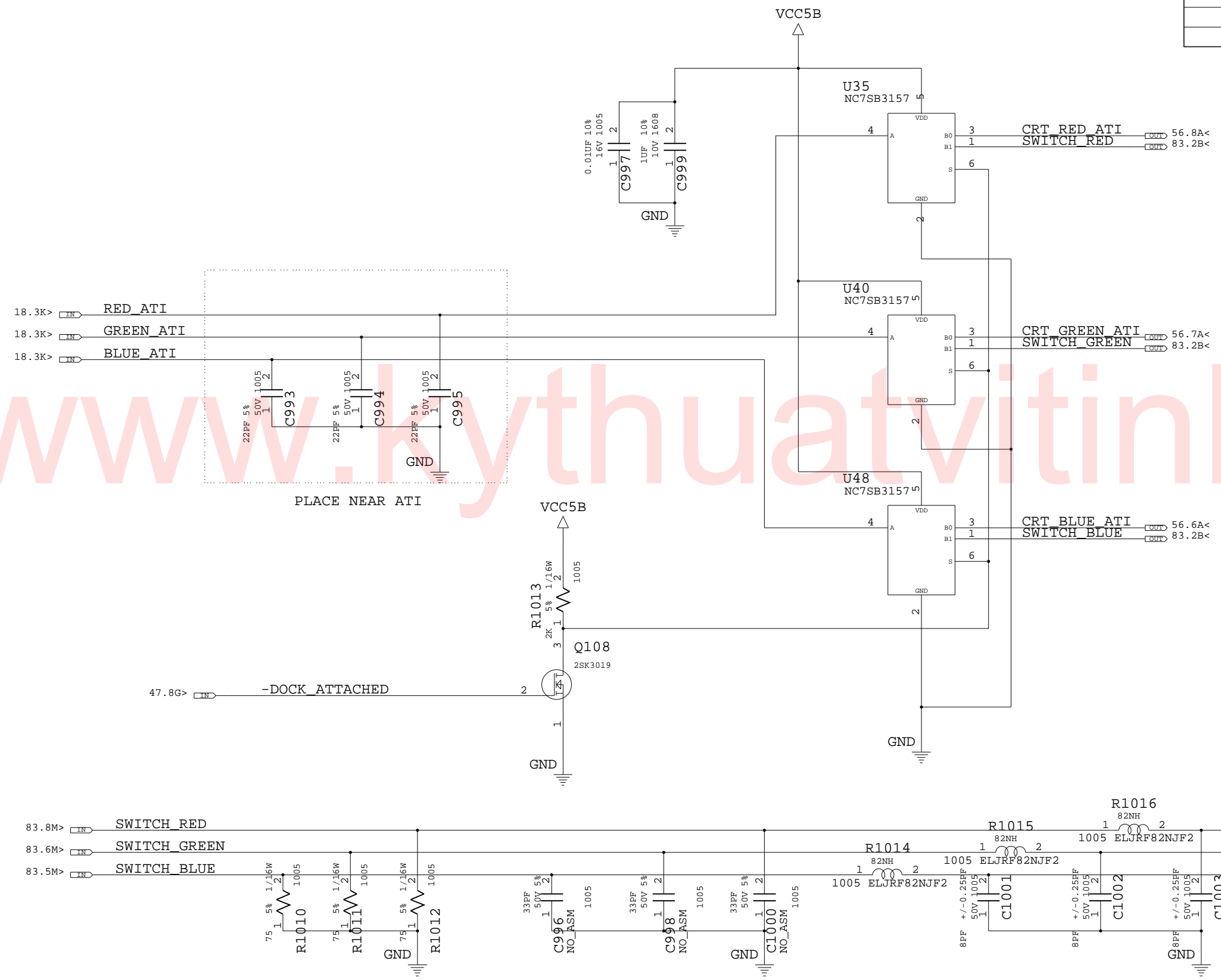

13R1439

DESIGNER	Y.I	08/03/04	PART NO.	13R1439	
CHECKED	Y.Y	08/03/04			
APPROVED	K.T	08/03/04	TITLE ROME-3.5 AP13 (V070)		
CLASS	K.T	08/03/04	RGB ANALOG SW		
THIS DOCUMENT IS THE PROPERTY OF IBM. ITS USE IS AUTHORIZED ONLY FOR RESPONDING TO A REQUEST FOR QUOTATION OR FOR THE PERFORMANCE OF WORK FOR IBM. ALL QUESTIONS MUST BE REFERRED TO THE IBM PURCHASING DEPARTMENT.					IBM CONFIDENTIAL